



LaserJet Pro M201, M202 LaserJet Pro MFP M225, M226

Replace and Repair Manual



**M201n
M202n**



**M201dw
M202dw**



**M225dn
M225rdn
M226dn**



**M225dw
M226dw**



www.hp.com/support/ljM201
www.hp.com/support/ljM202



www.hp.com/support/ljMFPM225
www.hp.com/support/ljMFPM226



HP LaserJet Pro MFP M225/M226 series and HP LaserJet Pro M201/M202 Printer series

Replace and Repair Manual

Copyright and License

© 2014 Copyright Hewlett-Packard Development Company, L.P.

Reproduction, adaptation, or translation without prior written permission is prohibited, except as allowed under the copyright laws.

The information contained herein is subject to change without notice.

The only warranties for HP products and services are set forth in the express warranty statements accompanying such products and services. Nothing herein should be construed as constituting an additional warranty. HP shall not be liable for technical or editorial errors or omissions contained herein.

Edition 1, 10/2014

Trademark Credits

Microsoft®, Windows®, Windows® XP, and Windows Vista® are U.S. registered trademarks of Microsoft Corporation.

ENERGY STAR® and the ENERGY STAR® mark are registered U.S. marks.

Conventions used in this guide

 **TIP:** Tips provide helpful hints or shortcuts.

 **NOTE:** Notes provide important information to explain a concept or to complete a task.

 **CAUTION:** Cautions indicate procedures that you should follow to avoid losing data or damaging the product.

 **WARNING!** Warnings alert you to specific procedures that you should follow to avoid personal injury, catastrophic loss of data, or extensive damage to the product.

Table of contents

1 Removal and replacement	1
Removal and replacement strategy	2
Cautions during removal and replacement	2
Electrostatic discharge	2
Required tools	2
Types of screws	4
Service strategy	5
Before performing service	5
After performing service	5
Post-service test	5
Print-quality test	5
Copy quality test	5
Parts removal order	6
Parts removal order: product base	6
Parts removal order: ADF and scanner (MFP models)	7
Removal and replacement procedures	8
Customer self repair (CSR) components	8
Pickup roller	8
Separation pad	9
External panels, covers, and doors: LaserJet Pro M201 and M202 series	10
Parts identification and location: HP LaserJet Pro M201 and M 202	10
Input and output tray assemblies	11
Dust cover	11
Input tray assembly	11
Output tray assembly	11
Left cover, duplex product	12
Left cover, simplex product	13
Top cover cap, duplex product	14
Remove the top cover cap, duplex product	14
Front cover assembly	15
Remove the front cover assembly	15
Right cover, duplex product	16

Remove the right cover, duplex product	17
Right cover, simplex product	18
Remove the right cover, simplex product	18
Duplex door and duplex frame, duplex product	20
Duplex door, duplex product	20
Duplex frame, duplex product	21
Rear cover, simplex product	22
Remove the rear cover, simplex product	22
Cartridge door, simplex product	23
Remove the cartridge door, simplex product	24
Top cover, simplex product	26
Remove the cartridge door, simplex product	26
Cartridge door, duplex product	29
Remove the cartridge door, duplex product	29
Top cover	33
Remove the top cover	33
External panels, covers, and doors: LaserJet Pro MFP M225 and M226 series	35
Parts identification and location: LaserJet Pro MFP M225, M226	35
Input and output tray assemblies (all models)	36
Dust cover	36
Input tray assembly	36
Output tray assembly	37
Left cover	37
Front cover assembly	38
Remove the front cover assembly	38
Right cover	40
Remove the right cover assembly	40
Scanner assembly	43
Remove the scanner assembly	43
Scanner hinges	45
Remove the scanner hinges	45
Duplex door and duplex frame	46
Duplex door	46
Duplex frame	47
Cartridge door	48
Remove the cartridge door	48
Top cover cap	50
Remove the top cover cap	50
Top cover	52
Remove the top cover	52
Transfer roller	54

Internal assemblies	54
Formatter PCA	54
Fuser	56
Remove the fuser	56
Reinstall the fuser	61
Main assemblies	63
Fuser film assembly	63
Remove the fuser film assembly	63
Reinstall the fuser film assembly	66
Laser/scanner assembly	66
Remove the laser/scanner assembly	66
Reinstall the laser/scanner assembly	69
Pickup assembly	70
Remove the pickup assembly	70
Reinstall the pickup assembly	75
Main motor	78
Remove the main motor	78
Reinstall the main-motor drive belt	82
Pickup solenoid	84
Remove the pickup solenoid	84
Engine controller PCA	88
Remove the engine controller PCA	88
Reinstall the engine controller PCA	93
Duplex-reverse solenoid, duplex product	96
Remove the duplex-reverse solenoid	96
Main fan, duplex product	99
Remove the main fan	99
Reinstall the main fan	101
Duplex-connector PCA, duplex product	102
Remove the duplex-connector PCA	102
Automatic document feeder and scanner components	105
Document feeder cover	106
Document feeder pick arm assembly	108
Remove the document feeder pick arm assembly	108
Document feeder core assembly	110
Remove the document feeder core assembly	110
Post scan pinch rollers	113
Remove the post scan pinch rollers	113
Document feeder base assembly	114
Remove the document feeder base assembly	114

2 Parts and diagrams: HP LaserJet Pro M201/M202 Printer series	117
Order parts by authorized service providers	118
Order replacement parts	118
Related documentation	118
Supplies part numbers	118
Customer self repair parts	119
Service parts	119
Whole-unit replacement part numbers	119
How to use the parts lists and diagrams	120
Covers	122
Duplex product	122
Simplex product	124
Internal assemblies	126
Internal assemblies (1 of 3)	126
Internal assemblies (2 of 3)	128
Internal assemblies (3 of 3)	130
Alphabetical parts list	132
Numerical parts list	135
3 Parts and diagrams: HP LaserJet Pro MFP M225/M226 series	139
Order parts by authorized service providers	140
Order replacement parts	140
Related documentation	140
Supplies part numbers	140
Customer self repair parts	141
Service parts	141
Whole-unit replacement part numbers	141
How to use the parts lists and diagrams	143
Covers	144
Internal assemblies	146
Internal assemblies (1 of 3)	146
Internal assemblies (2 of 3)	148
Internal assemblies (3 of 3)	150
Scanner and document feeder (ADF)	152
Scanner and document feeder (ADF) main assemblies	152
Document feeder internal components	154
Scanner assembly internal components	156
Scanner assembly internal components (1 of 2)	156
Scanner assembly internal components (2 of 2)	158
Alphabetical parts list	160
Numerical parts list	163

List of tables

Table 1-1	Common fasteners	4
Table 1-2	Parts identification: HP LaserJet Pro M201 and M 202	10
Table 1-3	Parts identification: LaserJet Pro MFP M225, M226	35
Table 1-4	Fuser film assembly components	65
Table 2-1	Order parts, accessories, and supplies	118
Table 2-2	Related documentation	118
Table 2-3	Supplies part numbers	118
Table 2-4	Customer replaceable units (CRU) kit part numbers	119
Table 2-5	Whole-unit replacement part numbers	119
Table 2-6	External panels and covers, duplex product	123
Table 2-7	External panels and covers, simplex product	125
Table 2-8	Internal assemblies (1 of 3)	127
Table 2-9	Internal assemblies (2 of 3)	129
Table 2-10	Internal assemblies (3 of 3)	131
Table 2-11	Alphabetical parts list	132
Table 2-12	Numerical parts list	135
Table 3-1	Order parts, accessories, and supplies	140
Table 3-2	Related documentation	140
Table 3-3	Supplies part numbers	140
Table 3-4	Customer replaceable units (CRU) kit part numbers	141
Table 3-5	Whole-unit replacement part numbers	141
Table 3-6	External panels and covers	145
Table 3-7	Internal assemblies (1 of 3)	147
Table 3-8	Internal assemblies (2 of 3)	149
Table 3-9	Internal assemblies (3 of 3)	151
Table 3-10	Scanner and document feeder (ADF) main assemblies	153
Table 3-11	Document feeder internal components	155
Table 3-12	Scanner assembly internal components (1 of 2)	157
Table 3-13	Scanner assembly internal components (2 of 2)	159
Table 3-14	Alphabetical parts list	160
Table 3-15	Numerical parts list	163

List of figures

Figure 1-1	Phillips and pozidrive screwdriver comparison	3
Figure 1-2	Parts removal order: product base (all models)	6
Figure 1-3	Parts removal order: ADF and scanner (MFP models)	7
Figure 1-4	Remove the pickup roller (1 of 2)	8
Figure 1-5	Remove the pickup roller (2 of 2)	8
Figure 1-6	Remove the separation pad assembly	9
Figure 1-7	Parts location: HP LaserJet Pro M201 and M202	10
Figure 1-8	Remove the dust cover (1 of 1)	11
Figure 1-9	Remove the input tray assembly (1 of 1)	11
Figure 1-10	Remove the output tray assembly (1 of 1)	12
Figure 1-11	Remove the left cover, duplex product (1 of 2)	12
Figure 1-12	Remove the left cover, duplex product (2 of 2)	13
Figure 1-13	Remove the left cover, simplex product (1 of 2)	13
Figure 1-14	Remove the left cover, simplex product (2 of 2)	14
Figure 1-15	Remove the top cover cap, duplex product (1 of 1)	14
Figure 1-16	Remove the front cover assembly (1 of 3)	15
Figure 1-17	Remove the front cover assembly (2 of 3)	16
Figure 1-18	Remove the front cover assembly (3 of 3)	16
Figure 1-19	Remove the right cover, duplex product (1 of 2)	17
Figure 1-20	Remove the right cover, duplex product (2 of 2)	17
Figure 1-21	Remove the right cover, simplex product (1 of 2)	18
Figure 1-22	Remove the right cover, simplex product (2 of 2)	19
Figure 1-23	Remove the duplex door assembly (1 of 1)	20
Figure 1-24	Remove the duplex frame (1 of 2)	21
Figure 1-25	Remove the duplex frame (2 of 2)	22
Figure 1-26	Remove the rear cover, simplex product (1 of 2)	23
Figure 1-27	Remove the rear cover, simplex product (2 of 2)	23
Figure 1-28	Remove the cartridge door, simplex product (1 of 5)	24
Figure 1-29	Remove the cartridge door, simplex product (2 of 5)	24
Figure 1-30	Remove the cartridge door, simplex product (3 of 5)	25
Figure 1-31	Remove the cartridge door, simplex product (4 of 5)	25
Figure 1-32	Remove the cartridge door, simplex product (5 of 5)	26

Figure 1-33	Remove the cartridge door, simplex product (1 of 5)	27
Figure 1-34	Remove the cartridge door, simplex product (2 of 5)	27
Figure 1-35	Remove the cartridge door, simplex product (3 of 5)	28
Figure 1-36	Remove the cartridge door, simplex product (4 of 5)	28
Figure 1-37	Remove the cartridge door, simplex product (5 of 5)	29
Figure 1-38	Remove the cartridge door, duplex product (1 of 5)	30
Figure 1-39	Remove the cartridge door, duplex product (2 of 5)	30
Figure 1-40	Remove the cartridge door, duplex product (3 of 5)	31
Figure 1-41	Remove the cartridge door, duplex product (4 of 5)	31
Figure 1-42	Remove the cartridge door, duplex product (5 of 5)	32
Figure 1-43	Remove the top cover (1 of 2)	33
Figure 1-44	Remove the top cover (2 of 2)	34
Figure 1-45	Parts location: LaserJet Pro MFP M225, M226	35
Figure 1-46	Remove the dust cover (1 of 1)	36
Figure 1-47	Remove the input tray assembly (1 of 1)	37
Figure 1-48	Remove the output tray assembly (1 of 1)	37
Figure 1-49	Remove the left cover (1 of 1)	38
Figure 1-50	Remove the front cover (1 of 3)	39
Figure 1-51	Remove the front cover (2 of 3)	39
Figure 1-52	Remove the front cover (3 of 3)	40
Figure 1-53	Remove the right cover (1 of 3)	41
Figure 1-54	Remove the right cover (2 of 3)	41
Figure 1-55	Remove the right cover (3 of 3)	42
Figure 1-56	Remove the scanner assembly (1 of 4)	43
Figure 1-57	Remove the scanner assembly (2 of 4)	43
Figure 1-58	Remove the scanner assembly (3 of 4)	44
Figure 1-59	Remove the scanner assembly (4 of 4)	44
Figure 1-60	Remove the scanner hinges (1 of 2)	45
Figure 1-61	Remove the scanner hinges (2 of 2)	46
Figure 1-62	Remove the duplex door assembly (1 of 1)	46
Figure 1-63	Remove the duplex frame (1 of 2)	47
Figure 1-64	Remove the duplex frame (2 of 2)	48
Figure 1-65	Remove the cartridge door (1 of 3)	49
Figure 1-66	Remove the cartridge door (2 of 3)	49
Figure 1-67	Remove the cartridge door (3 of 3)	50
Figure 1-68	Remove the top cover (1 of 1)	51
Figure 1-69	Remove the top cover (1 of 2)	52
Figure 1-70	Remove the top cover (2 of 2)	53
Figure 1-71	Remove the transfer roller	54
Figure 1-72	Remove the formatter PCA (1 of 2)	55
Figure 1-73	Remove the formatter PCA (2 of 2)	55

Figure 1-74	Remove the fuser (1 of 10)	56
Figure 1-75	Remove the fuser (2 of 10)	57
Figure 1-76	Remove the fuser (3 of 10)	57
Figure 1-77	Remove the fuser (4 of 10)	58
Figure 1-78	Remove the fuser (5 of 10)	58
Figure 1-79	Remove the fuser (6 of 10)	59
Figure 1-80	Remove the fuser (7 of 10)	59
Figure 1-81	Remove the fuser (8 of 10)	60
Figure 1-82	Remove the fuser (9 of 10)	60
Figure 1-83	Remove the fuser (10 of 10)	61
Figure 1-84	Reinstall the fuser; correct wire harness installation	61
Figure 1-85	Reinstall the fuser; incorrect wire harness installation	62
Figure 1-86	Remove the fuser film assembly (1 of 4)	63
Figure 1-87	Remove the fuser film assembly (2 of 4)	63
Figure 1-88	Remove the fuser film assembly (3 of 4)	64
Figure 1-89	Fuser film assembly overview	64
Figure 1-90	Fuser film assembly left side detail	64
Figure 1-91	Fuser film assembly right side detail	65
Figure 1-92	Remove the fuser film assembly (4 of 4)	65
Figure 1-93	Pressure release levers, LaserJet Pro M201 and M202 series	66
Figure 1-94	Pressure release levers, LaserJet Pro MFP M225 and M226 series	66
Figure 1-95	Remove the laser/scanner assembly (1 of 5)	67
Figure 1-96	Remove the laser/scanner assembly (2 of 5)	67
Figure 1-97	Remove the laser/scanner assembly (3 of 5)	68
Figure 1-98	Remove the laser/scanner assembly (4 of 5)	68
Figure 1-99	Remove the laser/scanner assembly (5 of 5)	69
Figure 1-100	Reinstall the laser/scanner assembly	69
Figure 1-101	Remove the pickup assembly (1 of 10)	70
Figure 1-102	Remove the pickup assembly (2 of 10)	71
Figure 1-103	Remove the pickup assembly (3 of 10)	71
Figure 1-104	Remove the pickup assembly (4 of 10)	72
Figure 1-105	Remove the pickup assembly (5 of 10)	72
Figure 1-106	Remove the pickup assembly (6 of 10)	73
Figure 1-107	Remove the pickup assembly (7 of 10)	73
Figure 1-108	Remove the pickup assembly (8 of 10)	74
Figure 1-109	Remove the pickup assembly (9 of 10)	74
Figure 1-110	Remove the pickup assembly (10 of 10)	75
Figure 1-111	Reinstall the pickup assembly (1 of 4; correct ground spring position)	75
Figure 1-112	Reinstall the pickup assembly (2 of 4; incorrect ground spring position)	76
Figure 1-113	Reinstall the pickup assembly (3 of 4; lift plate in raised position)	77
Figure 1-114	Reinstall the pickup assembly (4 of 4; lift plate in lowered position)	77

Figure 1-115	Remove the main motor (1 of 9)	78
Figure 1-116	Remove the main motor (2 of 9)	79
Figure 1-117	Remove the main motor (3 of 9)	79
Figure 1-118	Remove the main motor (4 of 9)	80
Figure 1-119	Remove the main motor (5 of 9)	80
Figure 1-120	Remove the main motor (6 of 9)	81
Figure 1-121	Remove the main motor (7 of 9)	81
Figure 1-122	Remove the main motor (8 of 9)	82
Figure 1-123	Remove the main motor (9 of 9)	82
Figure 1-124	Main-motor drive belt: correctly installed	83
Figure 1-125	Main-motor drive belt: incorrectly installed	83
Figure 1-126	Remove the pickup solenoid (1 of 7)	84
Figure 1-127	Remove the pickup solenoid (2 of 7)	85
Figure 1-128	Remove the pickup solenoid (3 of 7)	85
Figure 1-129	Remove the pickup solenoid (4 of 7)	86
Figure 1-130	Remove the solenoid (5 of 7)	86
Figure 1-131	Remove the pickup solenoid (6 of 7)	87
Figure 1-132	Remove the pickup solenoid (7 of 7)	87
Figure 1-133	Remove the engine controller PCA (1 of 10)	88
Figure 1-134	Remove the engine controller PCA (2 of 10)	89
Figure 1-135	Remove the engine controller PCA (3 of 10)	89
Figure 1-136	Remove the engine controller PCA (4 of 10)	90
Figure 1-137	Remove the engine controller PCA (5 of 10)	90
Figure 1-138	Remove the engine controller PCA (6 of 10)	91
Figure 1-139	Remove the engine controller PCA (7 of 10)	91
Figure 1-140	Remove the engine controller PCA (8 of 10)	92
Figure 1-141	Remove the engine controller PCA (9 of 10)	92
Figure 1-142	Remove the engine controller PCA (10 of 10)	93
Figure 1-143	Reinstall the engine controller PCA (1 of 4)	93
Figure 1-144	Reinstall the engine controller PCA (2 of 4)	94
Figure 1-145	Reinstall the engine controller PCA (3 of 4)	94
Figure 1-146	Reinstall the engine controller PCA (4 of 4)	95
Figure 1-147	Remove the duplex-reverse solenoid (1 of 5)	96
Figure 1-148	Remove the duplex-reverse solenoid (2 of 5)	97
Figure 1-149	Remove the duplex-reverse solenoid (3 of 5)	97
Figure 1-150	Remove the duplex-reverse solenoid (4 of 5)	98
Figure 1-151	Remove the duplex-reverse solenoid (5 of 5)	98
Figure 1-152	Remove the main fan (1 of 4)	99
Figure 1-153	Remove the main fan (2 of 4)	100
Figure 1-154	Remove the main fan (3 of 4)	100
Figure 1-155	Remove the main fan (4 of 4)	101

Figure 1-156	Reinstall the main fan	101
Figure 1-157	Remove the duplex-connector PCA (1 of 5)	102
Figure 1-158	Remove the duplex-connector PCA (2 of 5)	103
Figure 1-159	Remove the duplex-connector PCA (3 of 5)	103
Figure 1-160	Remove the duplex-connector PCA (4 of 5)	104
Figure 1-161	Remove the duplex-connector PCA (5 of 5)	104
Figure 1-162	Remove the document feeder cover (1 of 3)	106
Figure 1-163	Remove the document feeder cover (2 of 3)	106
Figure 1-164	Remove the document feeder cover (3 of 3)	107
Figure 1-165	Remove the document feeder pick arm assembly (1 of 3)	108
Figure 1-166	Remove the document feeder pick arm assembly (2 of 3)	108
Figure 1-167	Remove the document feeder pick arm assembly (3 of 3)	109
Figure 1-168	Remove the document feeder core assembly (1 of 5)	110
Figure 1-169	Remove the document feeder core assembly (2 of 5)	110
Figure 1-170	Remove the document feeder core assembly (3 of 5)	111
Figure 1-171	Remove the document feeder core assembly (4 of 5)	111
Figure 1-172	Remove the document feeder core assembly (5 of 5)	112
Figure 1-173	Remove the post scan pinch rollers	113
Figure 1-174	Remove the document feeder base assembly (1 of 4)	114
Figure 1-175	Remove the document feeder base assembly (2 of 4)	114
Figure 1-176	Remove the document feeder base assembly (3 of 4)	115
Figure 1-177	Remove the document feeder base assembly (4 of 4)	115
Figure 2-1	External panels and covers, duplex product	122
Figure 2-2	External panels and covers, simplex product	124
Figure 2-3	Internal assemblies (1 of 3)	126
Figure 2-4	Internal assemblies (2 of 3)	128
Figure 2-5	Internal assemblies (3 of 3)	130
Figure 3-1	External panels and covers	144
Figure 3-2	Internal assemblies (1 of 3)	146
Figure 3-3	Internal assemblies (2 of 3)	148
Figure 3-4	Internal assemblies (3 of 3)	150
Figure 3-5	Scanner and document feeder (ADF) main assemblies	152
Figure 3-6	Document feeder internal components	154
Figure 3-7	Scanner assembly internal components (1 of 2)	156
Figure 3-8	Scanner assembly internal components (2 of 2)	158

1 Removal and replacement

- [Removal and replacement strategy](#)
- [Service strategy](#)
- [Removal and replacement procedures](#)
- [Automatic document feeder and scanner components](#)

Removal and replacement strategy

Cautions during removal and replacement

 **WARNING!** Turn the product off, wait 5 seconds, and then remove the power cord before attempting to service the product. If this warning is not followed, severe injury can result, in addition to damage to the product. The power must be on for certain functional checks during troubleshooting. However, disconnect the power supply during parts removal.

Never operate or service the product with the protective cover removed from the laser/scanner assembly. The reflected beam, although invisible, can damage your eyes.



The sheet-metal parts might have sharp edges. Be careful when handling sheet-metal parts.

 **CAUTION:** Do not bend or fold the flat flexible cables (FFCs) during removal or installation. Also, do not straighten pre-folds in the FFCs. You *must* fully seat all FFCs in their connectors. Failure to fully seat an FFC into a connector can cause a short circuit in a PCA.

 **NOTE:** To install a self-tapping screw, first turn it counterclockwise to align it with the existing thread pattern, and then carefully turn it clockwise to tighten. Do not overtighten. If a self-tapping screw-hole becomes stripped, repair the screw-hole or replace the affected assembly.

 **TIP:** For clarity, some photos in this chapter show components removed that would not be removed to service the product. If necessary, remove the components listed at the beginning of a procedure before proceeding to service the product.

Electrostatic discharge

 **CAUTION:**  Some parts are sensitive to electrostatic discharge (ESD). Look for the ESD reminder when removing product parts. Always perform service work at an ESD-protected workstation or mat, or use an ESD strap. If an ESD workstation, mat, or strap is not available, ground yourself by touching the sheet-metal chassis *before* touching an ESD-sensitive part.

Protect the ESD-sensitive parts by placing them in ESD pouches when they are out of the product.

Required tools

- #2 Phillips screwdriver with a magnetic tip and a 152-mm (6-inch) shaft length
- Small flat-blade screwdriver
- Needle-nose pliers
- ESD mat or ESD strap (if one is available)
- Penlight (optional)

 **CAUTION:** Always use a Phillips screwdriver (callout 1). Do not use a pozidrive screwdriver (callout 2) or any motorized screwdriver. These can damage screws or screw threads.

Figure 1-1 Phillips and pozidrive screwdriver comparison



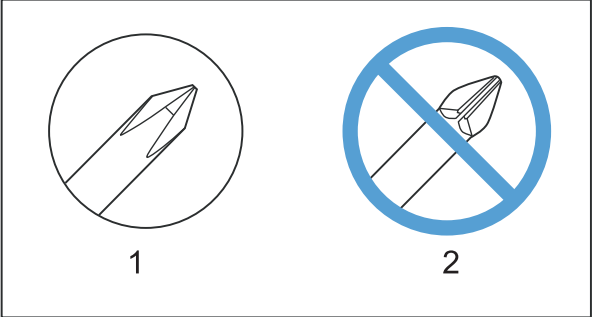

Types of screws

! WARNING! Make sure that components are replaced with the correct screw type. Using the incorrect screw (for example, substituting a long screw for the correct shorter screw) can cause damage to the product or interfere with product operation. Do not intermix screws that are removed from one component by using the screws that are removed from another component.

NOTE: The screw illustrations in the following table are for reference only. Screws might vary in size and appearance from those shown in this table.

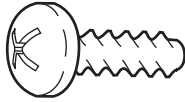
Table 1-1 Common fasteners

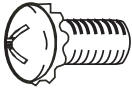
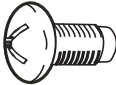
Example	Description	Size	Part Number
	Screw, with washer	M3X8	XA9-1420-000CN
		M4X6	XB2-7400-605CN
		M4X12	XA9-1422-000CN
	Screw, tapping, truss head	M4X10	XB4-7401-005CN
		M4X15	XB4-7401-609CN
	Screw, TP	M3X4	XB6-7300-405CN
		M3X6	XB6-7300-605CN
	Screw, D	M3X6	XA9-1670-000CN
		M3X8	XA9-1671-000CN
	Screw, machine	M3X4	XB6-7300-409CN
	Screw, machine, flat head	M3X4	XA9-0679-000CN
	Screw, machine, flanged pan head	M3X6	XB6-7300-805CN

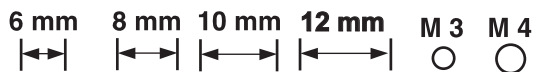

Service strategy

Before performing service

- Remove all paper from the product.
- Turn off the power using the power switch.
- Unplug the power cable and interface cable or cables.
- Place the product on an ESD workstation or mat, or use an ESD strap (if one is available). If an ESD workstation, mat, or strap is not available, ground yourself by touching the sheet-metal chassis *before* touching an ESD-sensitive part.
- Remove the print cartridge.

After performing service

- Plug in the power cable.
- Reinstall the print cartridge.
- Load paper in the product.

Post-service test

Perform the following test to verify that the repair or replacement was successful.

Print-quality test

1. Verify that you have completed the necessary reassembly steps.
2. Make sure that the tray contains clean, unmarked paper.
3. Attach the power cord and interface cable or interface cables, and then turn on the product.
4. Verify that the expected startup sounds occur.
5. Print a configuration page, and then verify that the expected printing sounds occur.
6. Print a demo page, and then verify that the print quality is as expected.
7. Send a print job from the host computer, and then verify that the output meets expectations.
8. Clean the outside of the product with a damp cloth.

Copy quality test

1. Verify that you have completed the necessary reassembly steps.
2. Perform steps 1-8 in test 1 to check basic print quality.
3. Place the configuration page in the document feeder.
4. Print a copy job, and then verify the results.
5. Clean the outside of the product by using a damp cloth.

Parts removal order

Parts removal order: product base

Figure 1-2 Parts removal order: product base (all models)

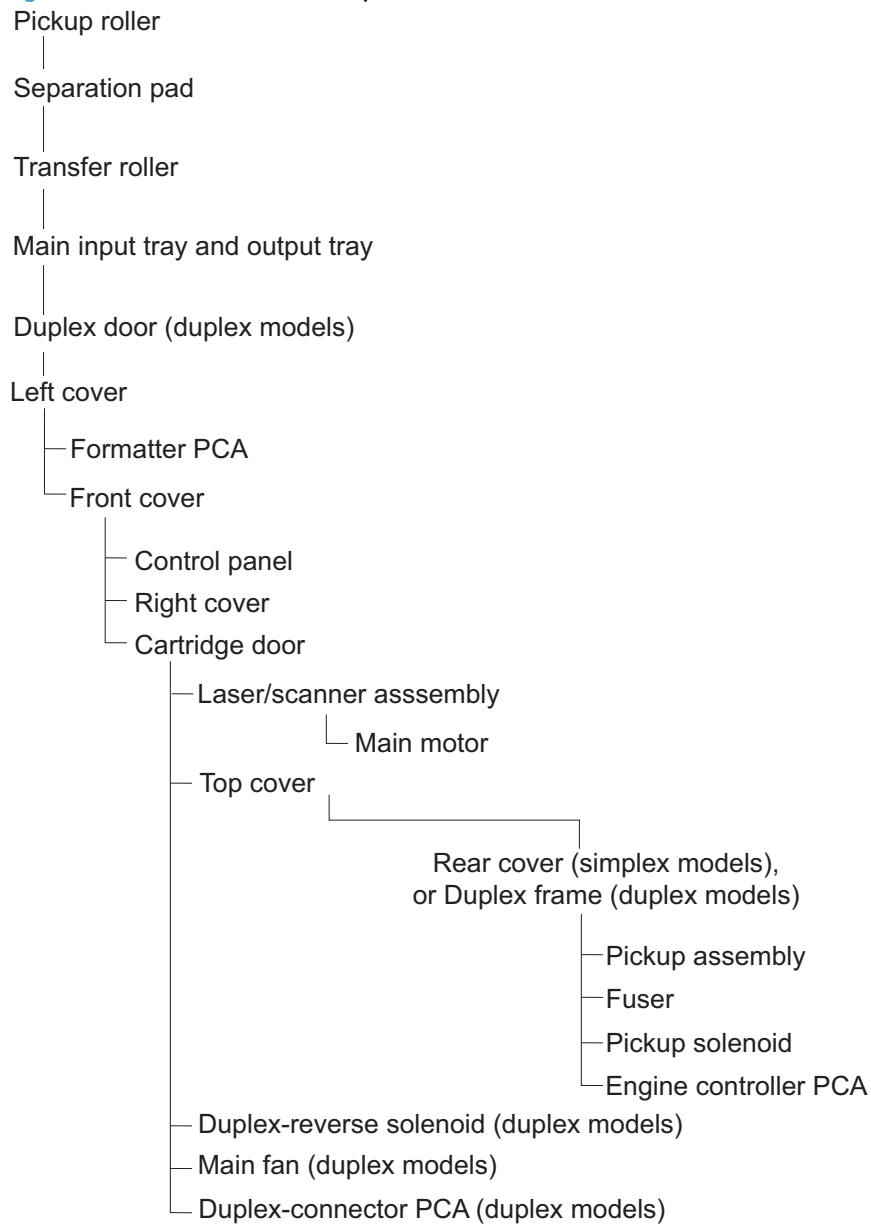

Parts removal order: ADF and scanner (MFP models)

 **IMPORTANT:** In the following list, parts shown with blue text should be removed only in a clean-room environment.

Figure 1-3 Parts removal order: ADF and scanner (MFP models)

Automatic document feeder assembly

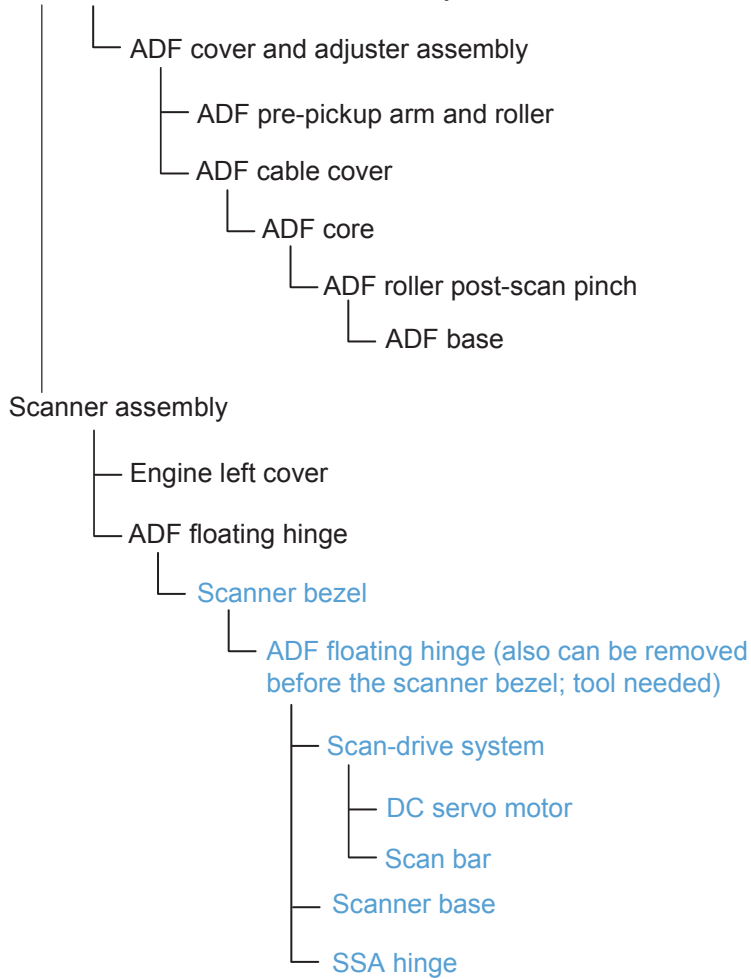

Removal and replacement procedures

Customer self repair (CSR) components

Pickup roller

⚠ CAUTION: Do not touch the sponge portion of the roller. Skin oils can cause paper handling problems.

1. Release two tabs.

Figure 1-4 Remove the pickup roller (1 of 2)

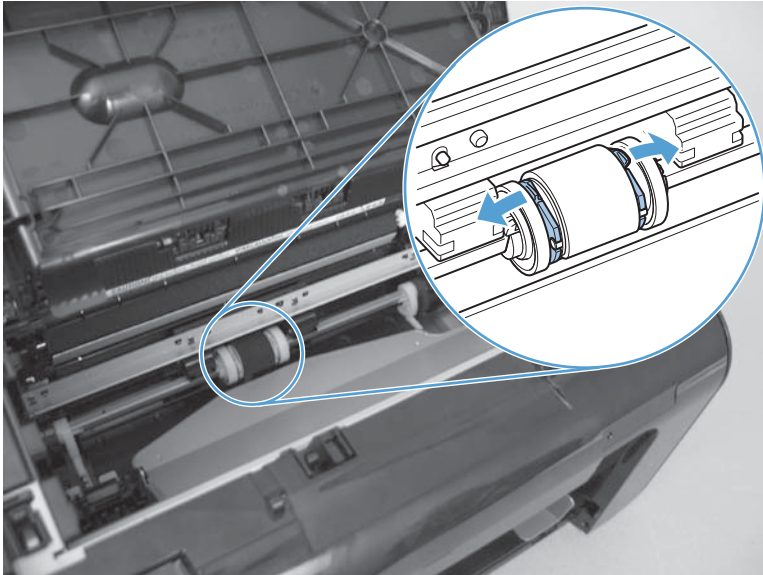

2. Rotate the roller away from the product to remove it.

Figure 1-5 Remove the pickup roller (2 of 2)

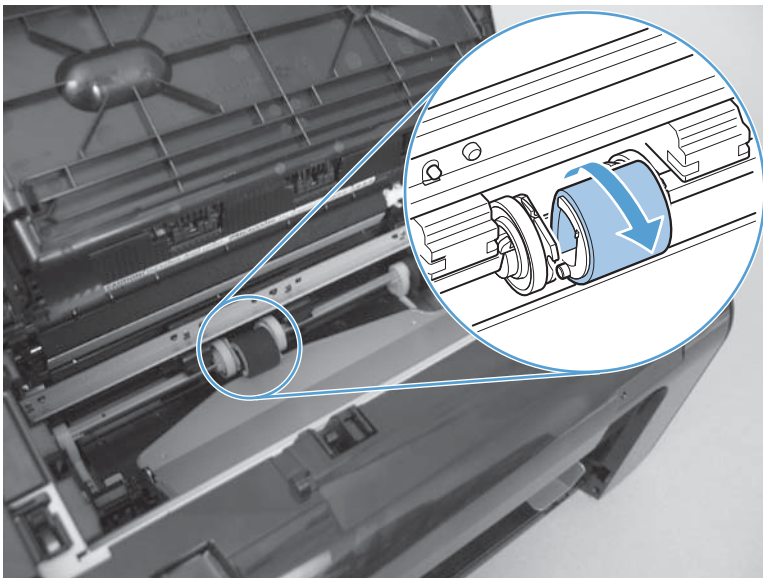

Separation pad

⚠ CAUTION: Do not touch the sponge portion of the pad. Skin oils can cause paper handling problems.

1. Place the product rear-side down to access the separation pad assembly.

⚠ CAUTION: Dirt and debris can scratch the product covers. Place the product on a cloth or other clean surface.

2. Remove two screws (callout 1) and then remove the separation pad assembly (callout 2).

Figure 1-6 Remove the separation pad assembly

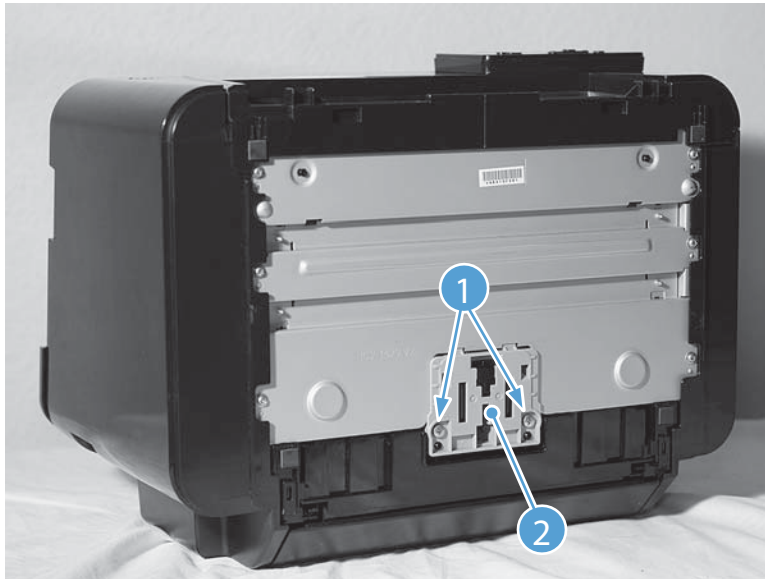

External panels, covers, and doors: LaserJet Pro M201 and M202 series

Parts identification and location: HP LaserJet Pro M201 and M202

Figure 1-7 Parts location: HP LaserJet Pro M201 and M202

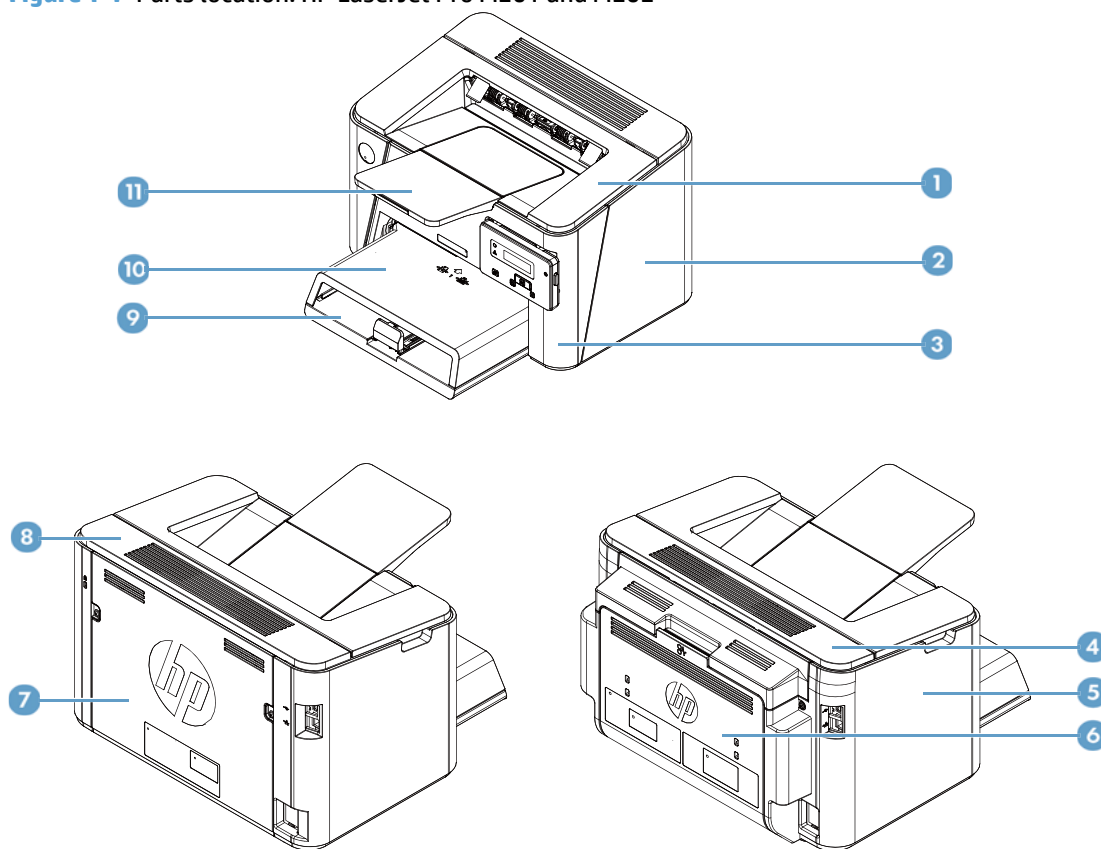

Table 1-2 Parts identification: HP LaserJet Pro M201 and M202

Item	Description
1	Cartridge door
2	Right cover
3	Front cover assembly
4	Top cover cap (duplex product only)
5	Left cover
6	Duplex door assembly (duplex product only)
7	Rear cover (simplex product only)
8	Top cover (simplex product only)
9	Input tray assembly
10	Dust cover
11	Output tray assembly

Input and output tray assemblies

Dust cover

Release two shafts (callout 1) and remove the dust cover (callout 2).

Figure 1-8 Remove the dust cover (1 of 1)



Input tray assembly

1. Remove the dust cover.
2. Pull the input tray assembly (callout 1) towards the front side of the printer and remove it.

Figure 1-9 Remove the input tray assembly (1 of 1)



Output tray assembly

Hold up the output tray assembly (callout 1) and remove it.

Figure 1-10 Remove the output tray assembly (1 of 1)



Left cover, duplex product

1. Open the cartridge door.
2. Open the duplex door assembly.
3. Remove one screw (callout 1).

Figure 1-11 Remove the left cover, duplex product (1 of 2)



4. Release four tabs (callout 1) and remove the left cover (callout 2).

Figure 1-12 Remove the left cover, duplex product (2 of 2)



Left cover, simplex product

1. Open the cartridge door.
2. Remove one screw (callout 1).

Figure 1-13 Remove the left cover, simplex product (1 of 2)



3. Release four tabs (callout 1) and remove the left cover (callout 2).

Figure 1-14 Remove the left cover, simplex product (2 of 2)

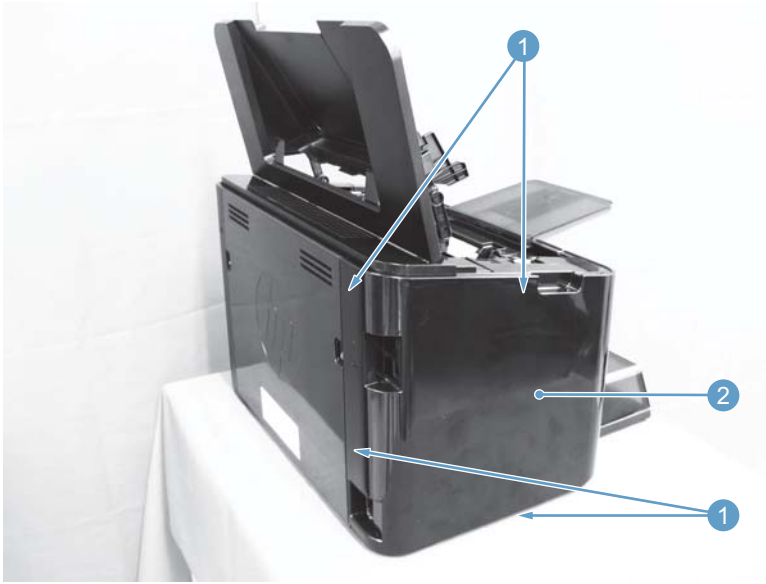

Top cover cap, duplex product

Before proceeding, remove the following components:

- Left cover. See [Left cover, duplex product on page 12](#).

Remove the top cover cap, duplex product

- ▲ Slide the top cover cap (callout 1) towards the left side of the printer and remove it.

Figure 1-15 Remove the top cover cap, duplex product (1 of 1)



Front cover assembly

Before proceeding, remove the following components:

- Dust cover. See [Dust cover on page 11](#)
- Input tray assembly. See [Input tray assembly on page 11](#).
- Output tray assembly. See [Output tray assembly on page 11](#).
- Left cover. See [Left cover, duplex product on page 12](#) or [Left cover, simplex product on page 13](#).

Remove the front cover assembly

1. Disconnect the FFC (callout 1).

Figure 1-16 Remove the front cover assembly (1 of 3)

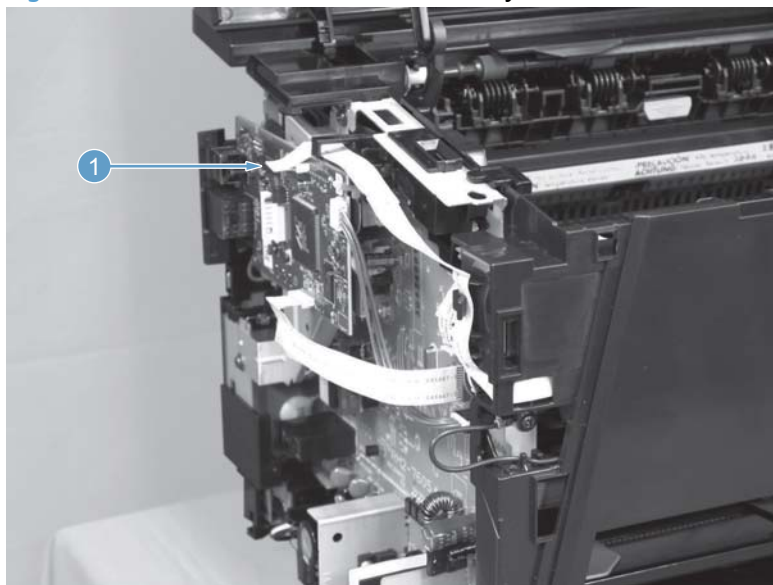

2. Remove one screw (callout 1) and the grounding cable (callout 2).

Figure 1-17 Remove the front cover assembly (2 of 3)

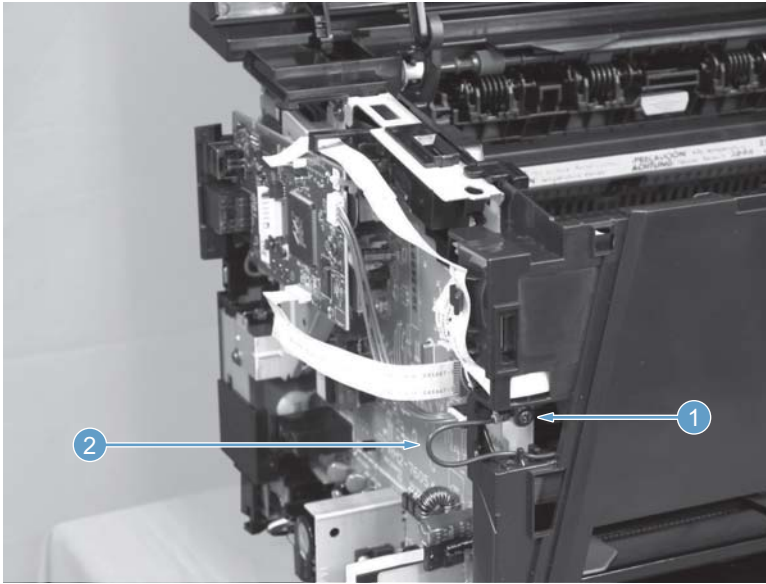

3. Remove one screw (callout 1), then release five tabs (callout 2) and remove the front cover assembly (callout 3).

Figure 1-18 Remove the front cover assembly (3 of 3)

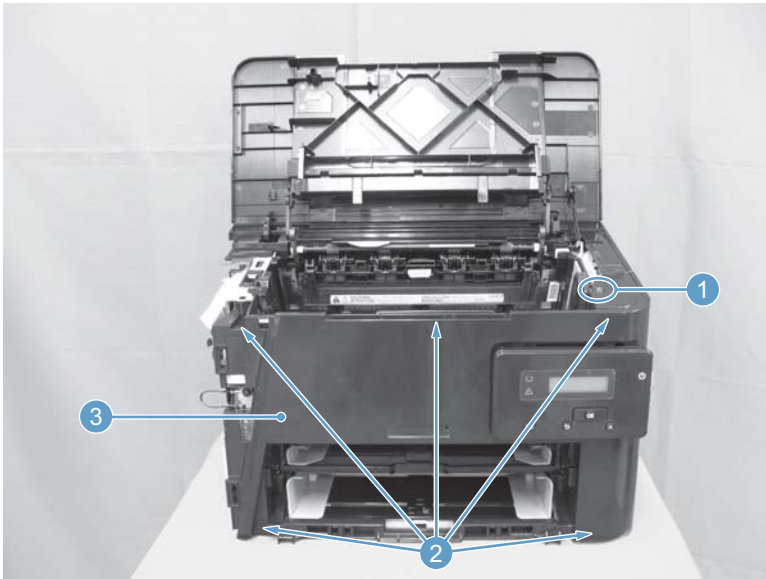

Right cover, duplex product

Before proceeding, remove the following components:

- Dust cover. See [Dust cover on page 11](#)
- Input tray assembly. See [Input tray assembly on page 11](#).
- Output tray assembly. See [Output tray assembly on page 11](#).

- Left cover. See [Left cover, duplex product on page 12](#).
- Front cover assembly. See [Front cover assembly on page 15](#).

Remove the right cover, duplex product

1. Remove one screw (callout 1).

Figure 1-19 Remove the right cover, duplex product (1 of 2)



2. Release five tabs (callout 1) and remove the right cover (callout 2).

Figure 1-20 Remove the right cover, duplex product (2 of 2)



Right cover, simplex product

Before proceeding, remove the following components:

- Dust cover. See [Dust cover on page 11](#)
- Input tray assembly. See [Input tray assembly on page 11](#).
- Output tray assembly. See [Output tray assembly on page 11](#).
- Left cover. See [Left cover, simplex product on page 13](#).
- Front cover assembly. See [Front cover assembly on page 15](#).

Remove the right cover, simplex product

1. Remove one screw (callout 1).

Figure 1-21 Remove the right cover, simplex product (1 of 2)



2. Release four tabs (callout 1) and remove the right cover (callout 2).

Figure 1-22 Remove the right cover, simplex product (2 of 2)

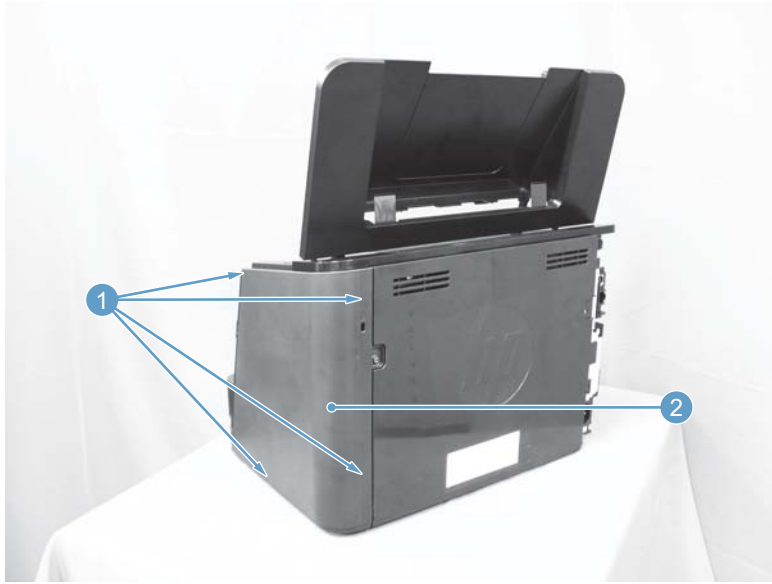

Duplex door and duplex frame, duplex product

Duplex door, duplex product

Release two shafts (callout 1) and remove the duplex door ass'y (callout 2).

Figure 1-23 Remove the duplex door assembly (1 of 1)



Duplex frame, duplex product

Before proceeding, remove the following components:

- Left cover. See [Left cover, duplex product on page 12](#).
- Right cover. See [Right cover, duplex product on page 16](#).
- Top cover cap (duplex models). See [Top cover cap, duplex product on page 14](#).
- Duplex door. See [Duplex door, duplex product on page 20](#).

Remove the duplex frame

1. Release two tabs (callout 1), and then remove the duplex reverse guide (callout 2).

Figure 1-24 Remove the duplex frame (1 of 2)

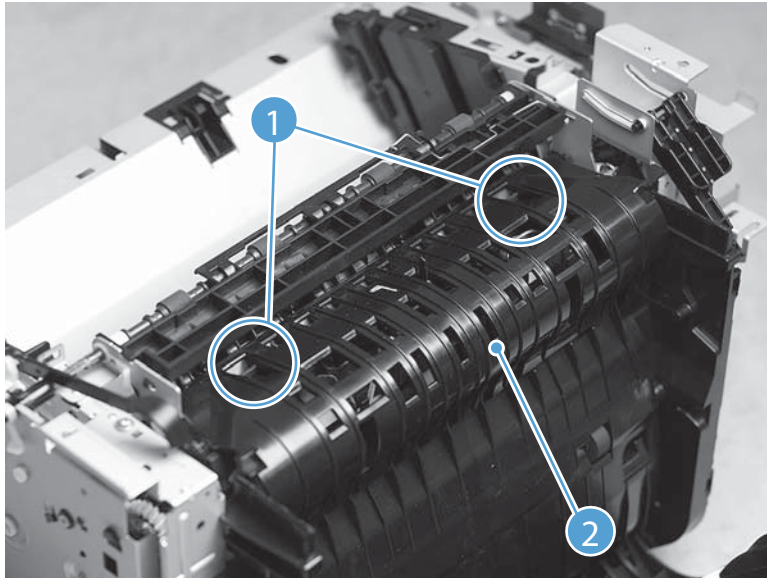

2. Remove four screws (callout 1), and then remove the duplex frame (callout 2).

Figure 1-25 Remove the duplex frame (2 of 2)

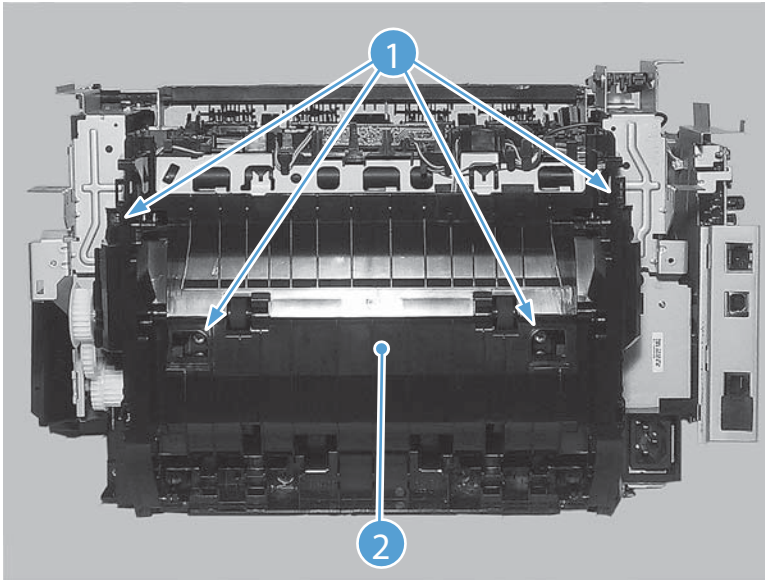

Rear cover, simplex product

Before proceeding, remove the following components:

- Dust cover. See [Dust cover on page 11](#)
- Input tray assembly. See [Input tray assembly on page 11](#).
- Output tray assembly. See [Output tray assembly on page 11](#).
- Left cover. See [Left cover, simplex product on page 13](#).
- Front cover assembly. See [Front cover assembly on page 15](#).
- Right cover. See [Right cover, simplex product on page 18](#).

Remove the rear cover, simplex product

1. Release three tabs at the top of the cover (callout 1), and then release three tabs at the bottom of the cover (callout 2).

Figure 1-26 Remove the rear cover, simplex product (1 of 2)

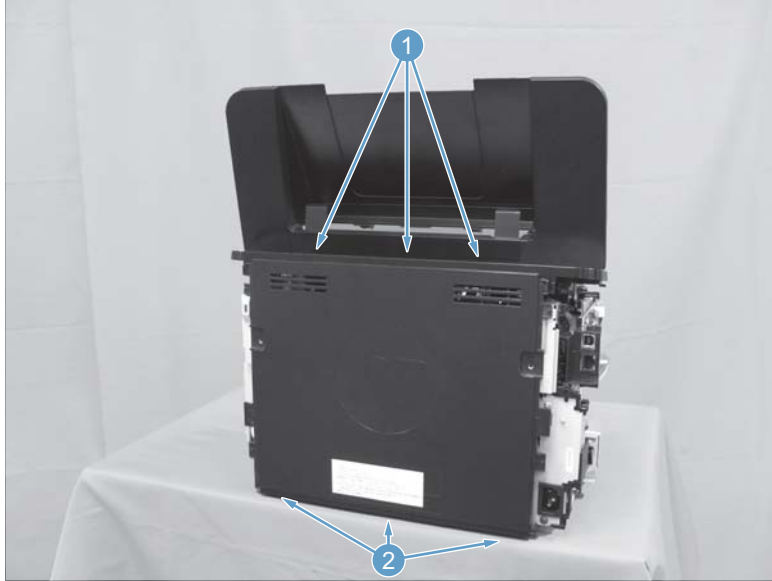

2. Remove the rear cover, simplex product (callout 1).

Figure 1-27 Remove the rear cover, simplex product (2 of 2)

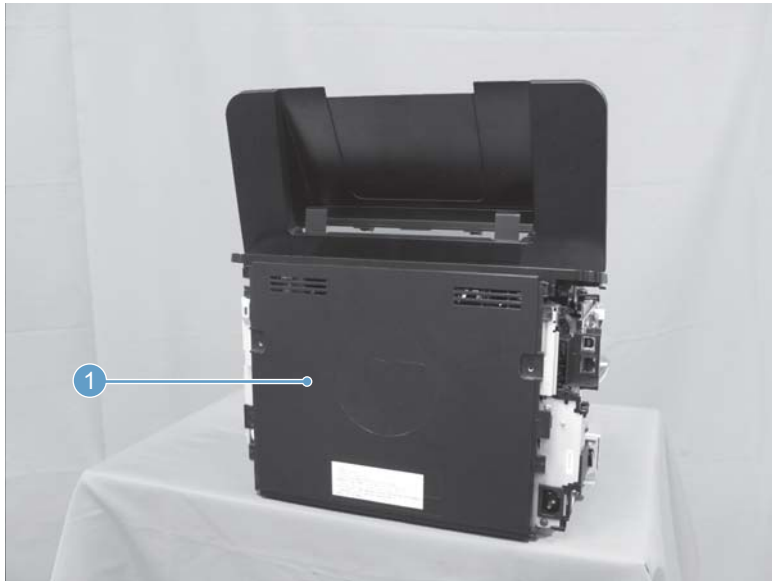

Cartridge door, simplex product

Before proceeding, remove the following components:

- Dust cover. See [Dust cover on page 11](#)
- Input tray assembly. See [Input tray assembly on page 11](#).
- Output tray assembly. See [Output tray assembly on page 11](#).
- Left cover. See [Left cover, simplex product on page 13](#).
- Front cover assembly. See [Front cover assembly on page 15](#).

- Right cover. See [Right cover, simplex product on page 18](#).
- Rear cover, simplex product. See [Rear cover, simplex product on page 22](#).

Remove the cartridge door, simplex product

1. Release three tabs (callout 1).

Figure 1-28 Remove the cartridge door, simplex product (1 of 5)

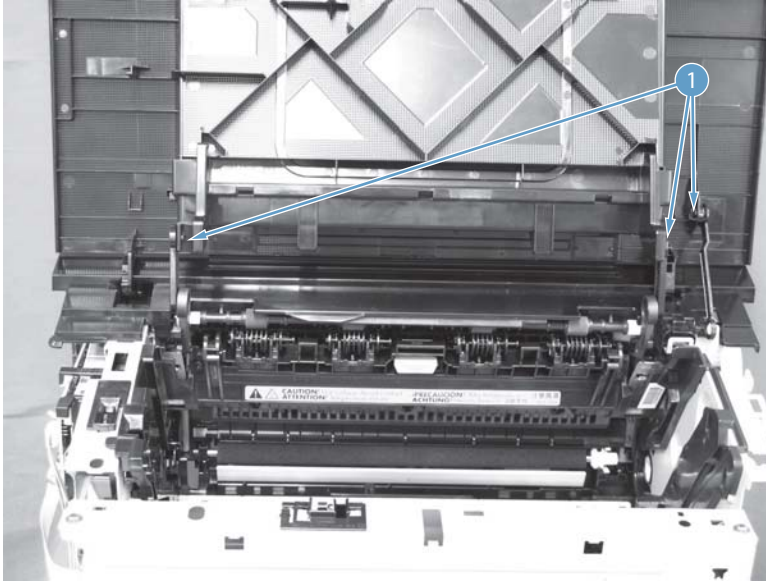

2. Release three link arms (callout 1).

Figure 1-29 Remove the cartridge door, simplex product (2 of 5)

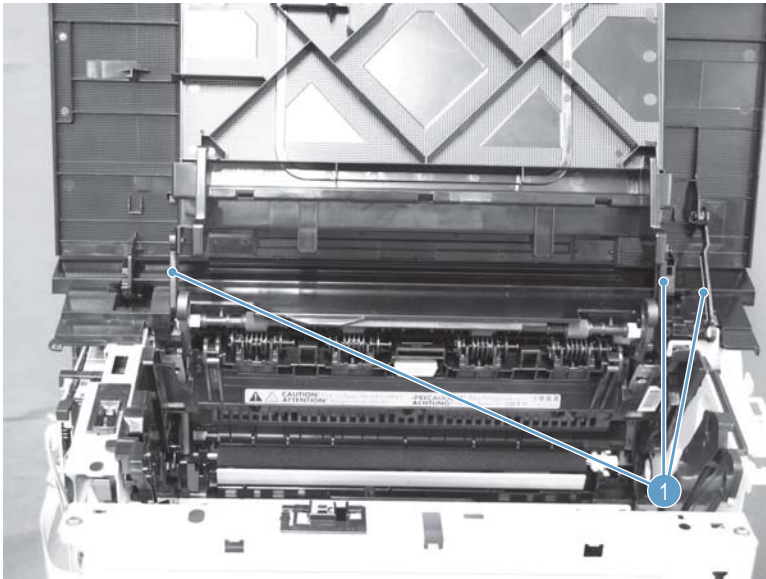

3. Remove the cartridge door (callout 1) and the top cover (callout 2) together.

Figure 1-30 Remove the cartridge door, simplex product (3 of 5)

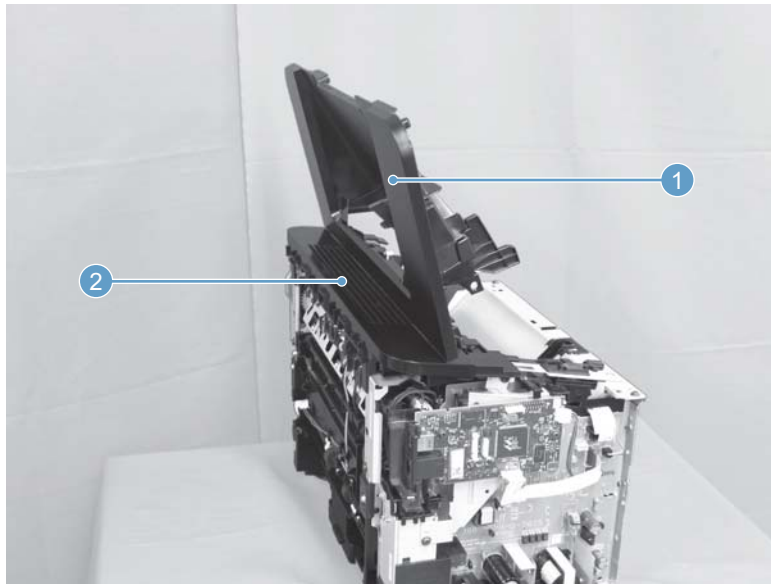

4. Release one tab (callout 1) and remove the cartridge shaft cover (callout 2).

Figure 1-31 Remove the cartridge door, simplex product (4 of 5)

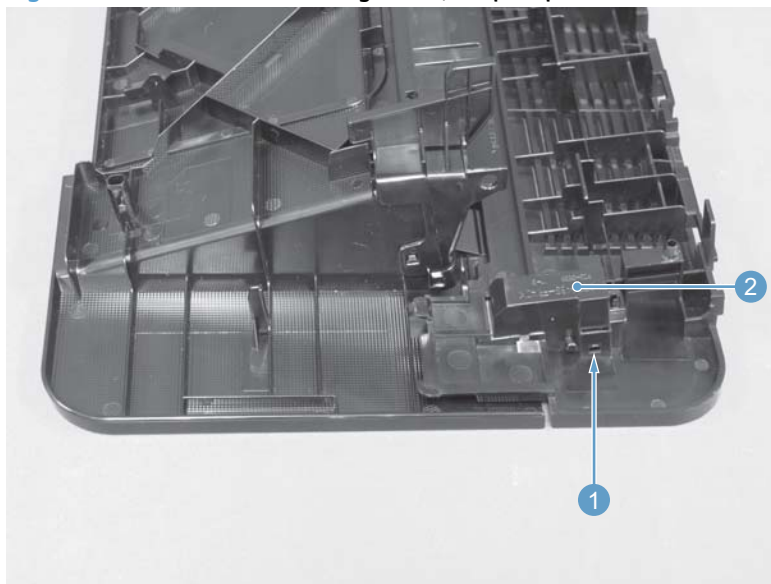

5. Release two shafts (callout 1) and remove the cartridge door from the top cover.

Figure 1-32 Remove the cartridge door, simplex product (5 of 5)



Top cover, simplex product

Before proceeding, remove the following components:

- Dust cover. See [Dust cover on page 11](#)
- Input tray assembly. See [Input tray assembly on page 11](#).
- Output tray assembly. See [Output tray assembly on page 11](#).
- Left cover. See [Left cover, simplex product on page 13](#).
- Front cover assembly. See [Front cover assembly on page 15](#).
- Right cover. See [Right cover, simplex product on page 18](#).
- Rear cover, simplex product. See [Rear cover, simplex product on page 22](#).

Remove the cartridge door, simplex product

1. Release three tabs (callout 1).

Figure 1-33 Remove the cartridge door, simplex product (1 of 5)

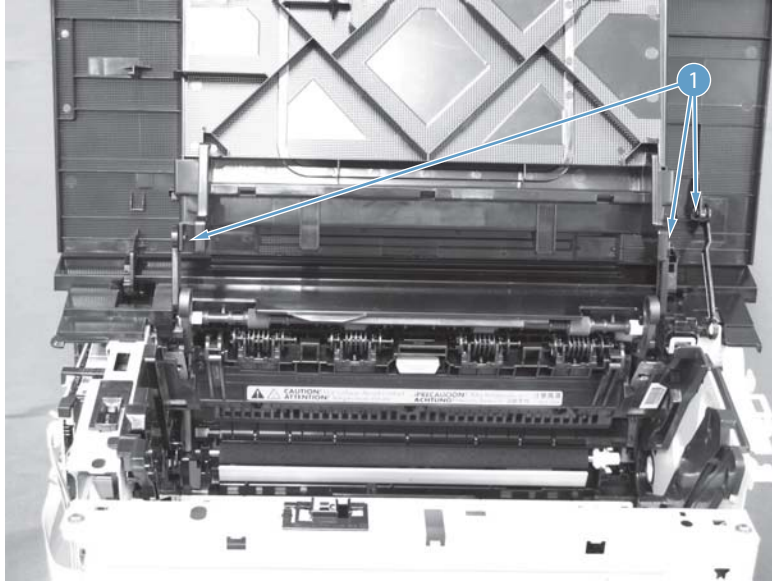

2. Release three link arms (callout 1).

Figure 1-34 Remove the cartridge door, simplex product (2 of 5)

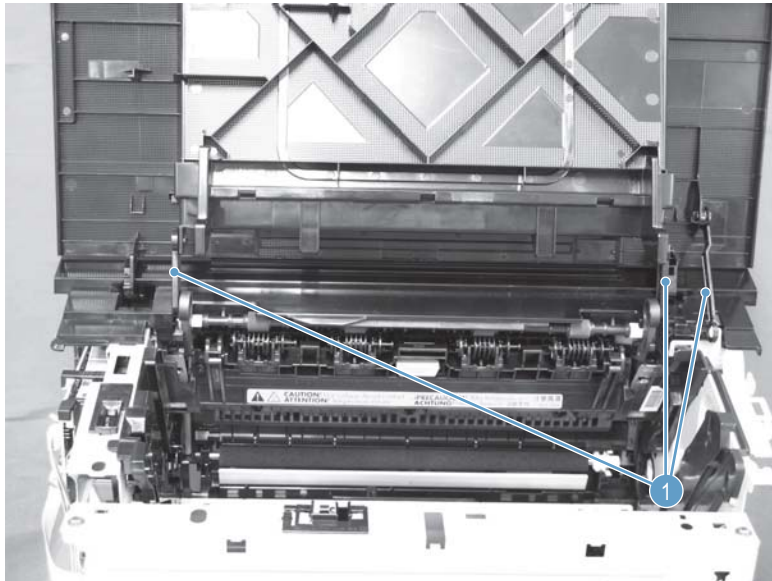

3. Remove the cartridge door (callout 1) and the top cover (callout 2) together.

Figure 1-35 Remove the cartridge door, simplex product (3 of 5)

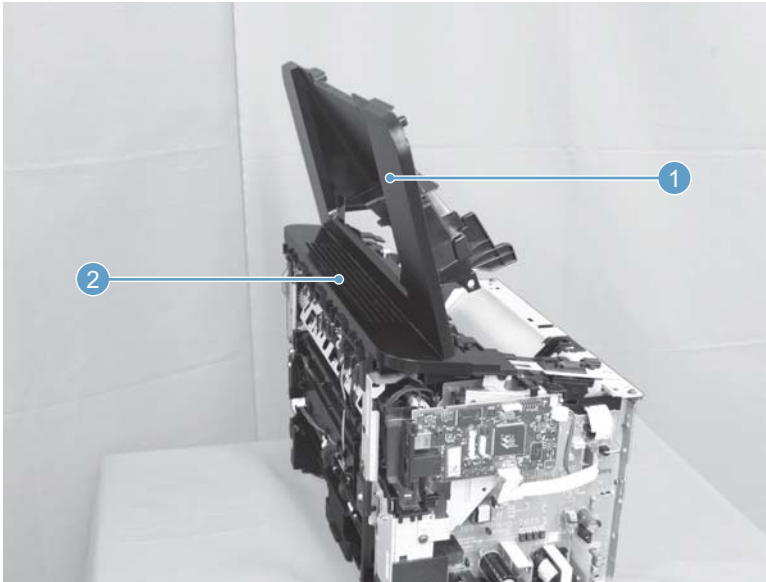

4. Release one tab (callout 1) and remove the cartridge shaft cover (callout 2).

Figure 1-36 Remove the cartridge door, simplex product (4 of 5)

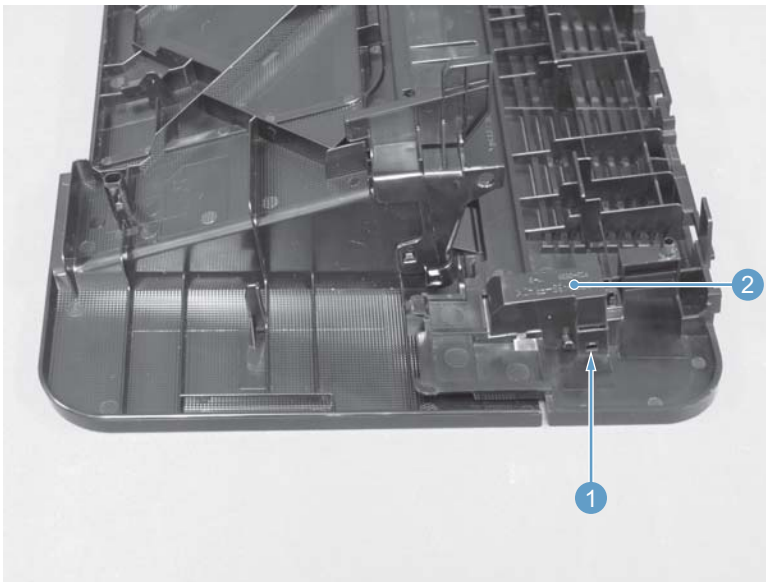

5. Release two shafts (callout 1) and remove the top cover from the cartridge door.

Figure 1-37 Remove the cartridge door, simplex product (5 of 5)



Cartridge door, duplex product

Before proceeding, remove the following components:

- Dust cover. See [Dust cover on page 11](#)
- Input tray assembly. See [Input tray assembly on page 11](#).
- Output tray assembly. See [Output tray assembly on page 11](#).
- Left cover. See [Left cover, duplex product on page 12](#).
- Front cover assembly. See [Front cover assembly on page 15](#).
- Right cover. See [Right cover, duplex product on page 16](#).
- Top cover cap, duplex product. See [Top cover cap, duplex product on page 14](#).

Remove the cartridge door, duplex product

1. Release three tabs (callout 1).

Figure 1-38 Remove the cartridge door, duplex product (1 of 5)

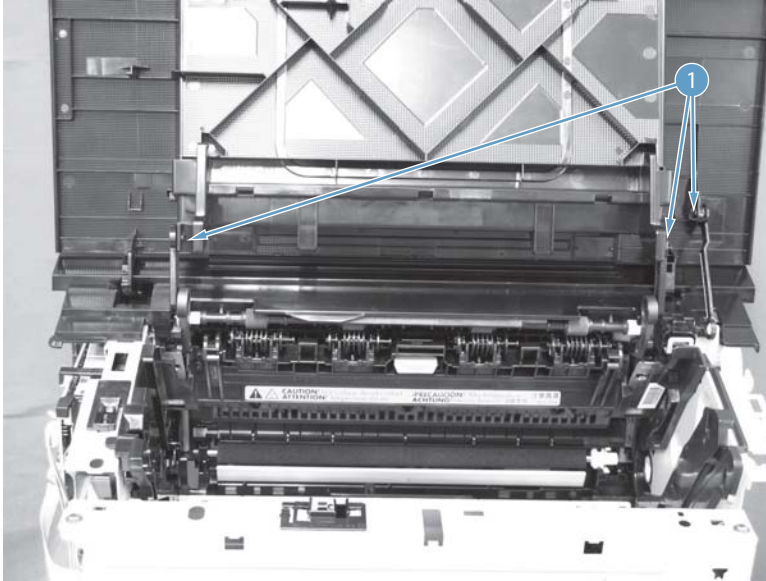

2. Release three link arms (callout 1).

Figure 1-39 Remove the cartridge door, duplex product (2 of 5)

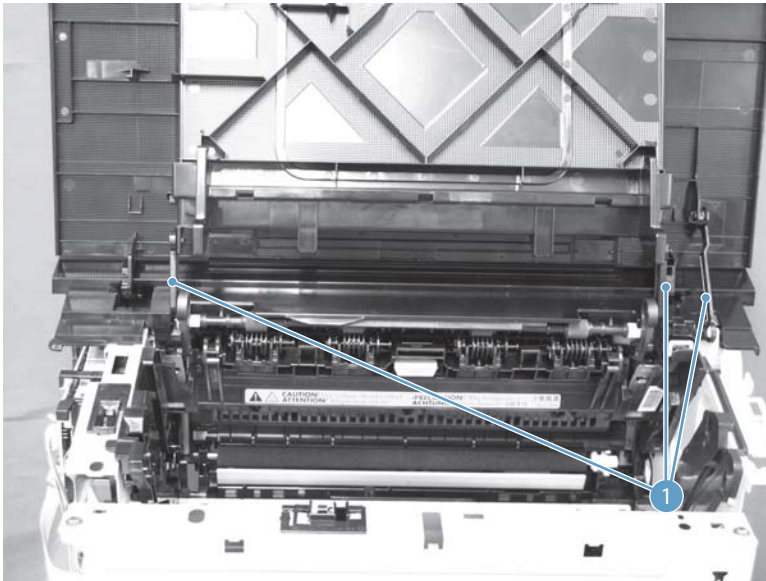

3. Remove two screws (callout 1).

Figure 1-40 Remove the cartridge door, duplex product (3 of 5)

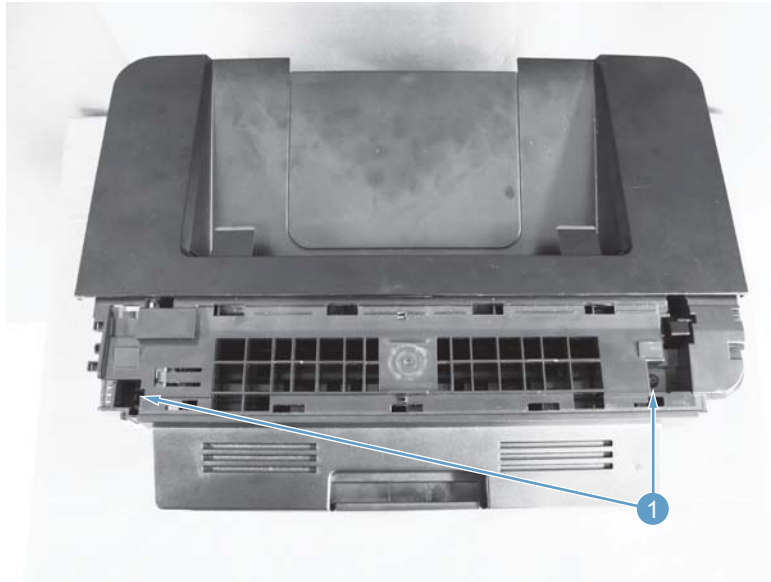

4. Remove the cartridge door (callout 1) and the top cover (callout 2) together.

Figure 1-41 Remove the cartridge door, duplex product (4 of 5)

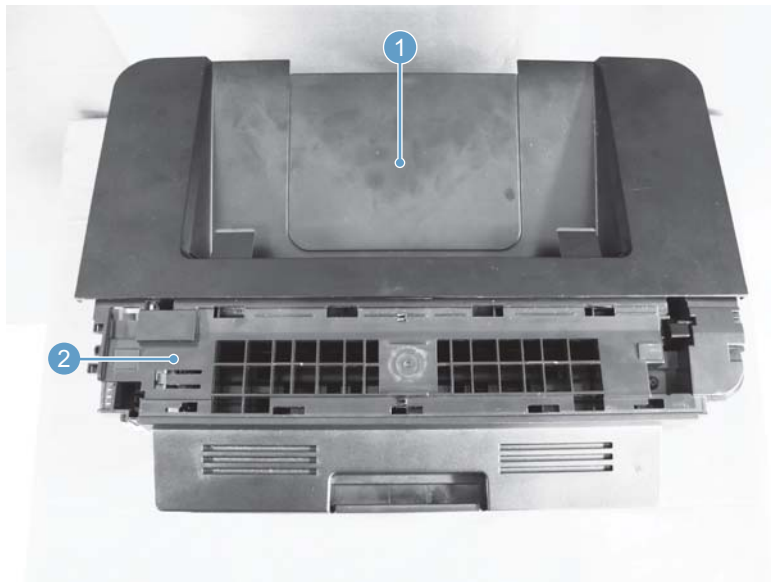

5. Release two shafts (callout 1) and remove the cartridge door from the top cover.

Figure 1-42 Remove the cartridge door, duplex product (5 of 5)

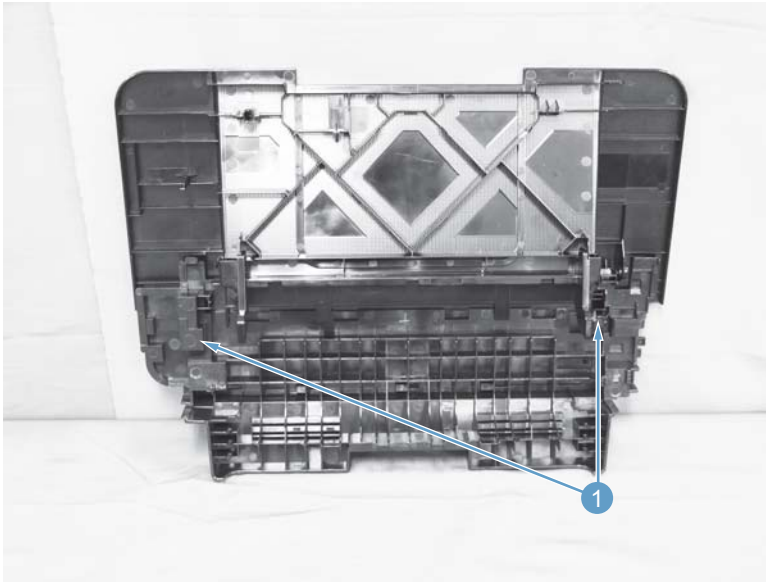

Top cover

Before proceeding, remove the following components:

- Main-input tray. See [Input tray assembly on page 11](#).
- Output bin tray extension. See [Output tray assembly on page 11](#).
- Left cover. See [Left cover, duplex product on page 12](#) or [Left cover, duplex product on page 12](#).
- Right cover. See [Right cover, duplex product on page 16](#) or [Right cover, simplex product on page 18](#).
- Cartridge door. See [Cartridge door, duplex product on page 29](#) or [Cartridge door, simplex product on page 23](#).
- Front cover. See [Front cover assembly on page 15](#).

Remove the top cover

1. Remove two screws (callout 1).

⚠ CAUTION: The upper-cartridge door arms (callout 2) can become easily be dislodged from the lower arms. Do not lose the upper-cartridge door arms while servicing the product.

Figure 1-43 Remove the top cover (1 of 2)

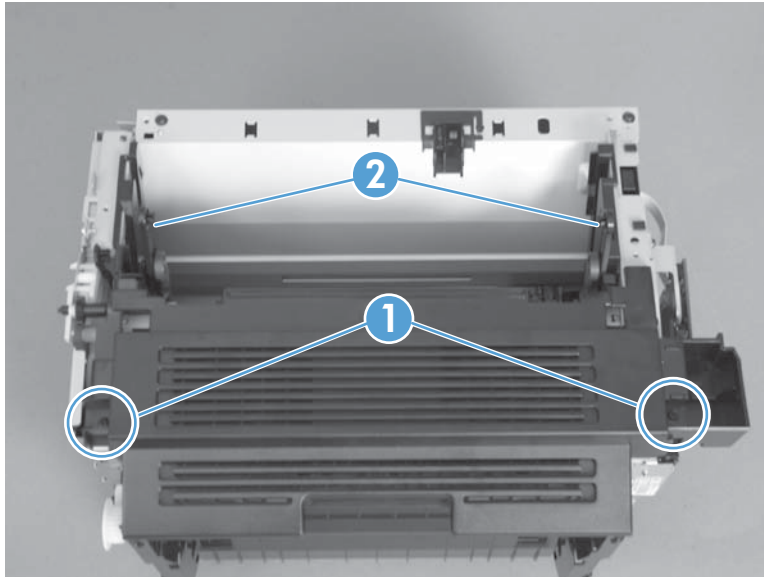

2. Lift the cover up and off the product to remove it.

Figure 1-44 Remove the top cover (2 of 2)

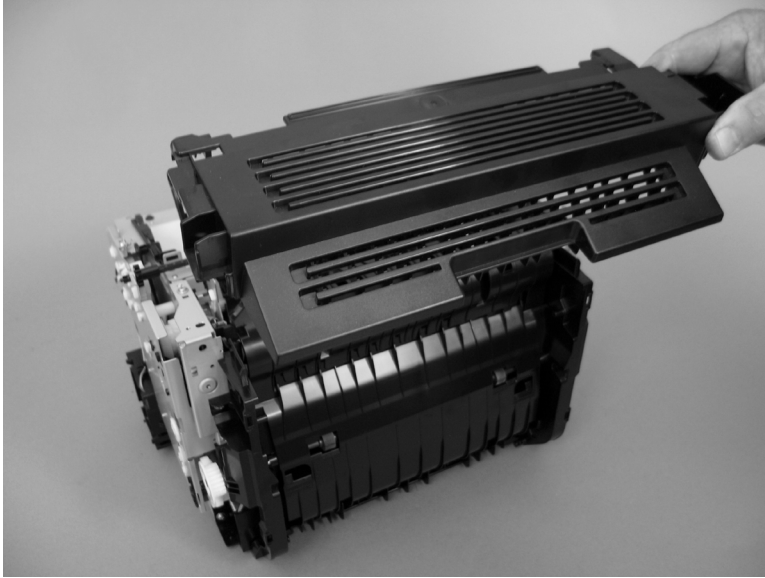

External panels, covers, and doors: LaserJet Pro MFP M225 and M226 series

Parts identification and location: LaserJet Pro MFP M225, M226

Figure 1-45 Parts location: LaserJet Pro MFP M225, M226

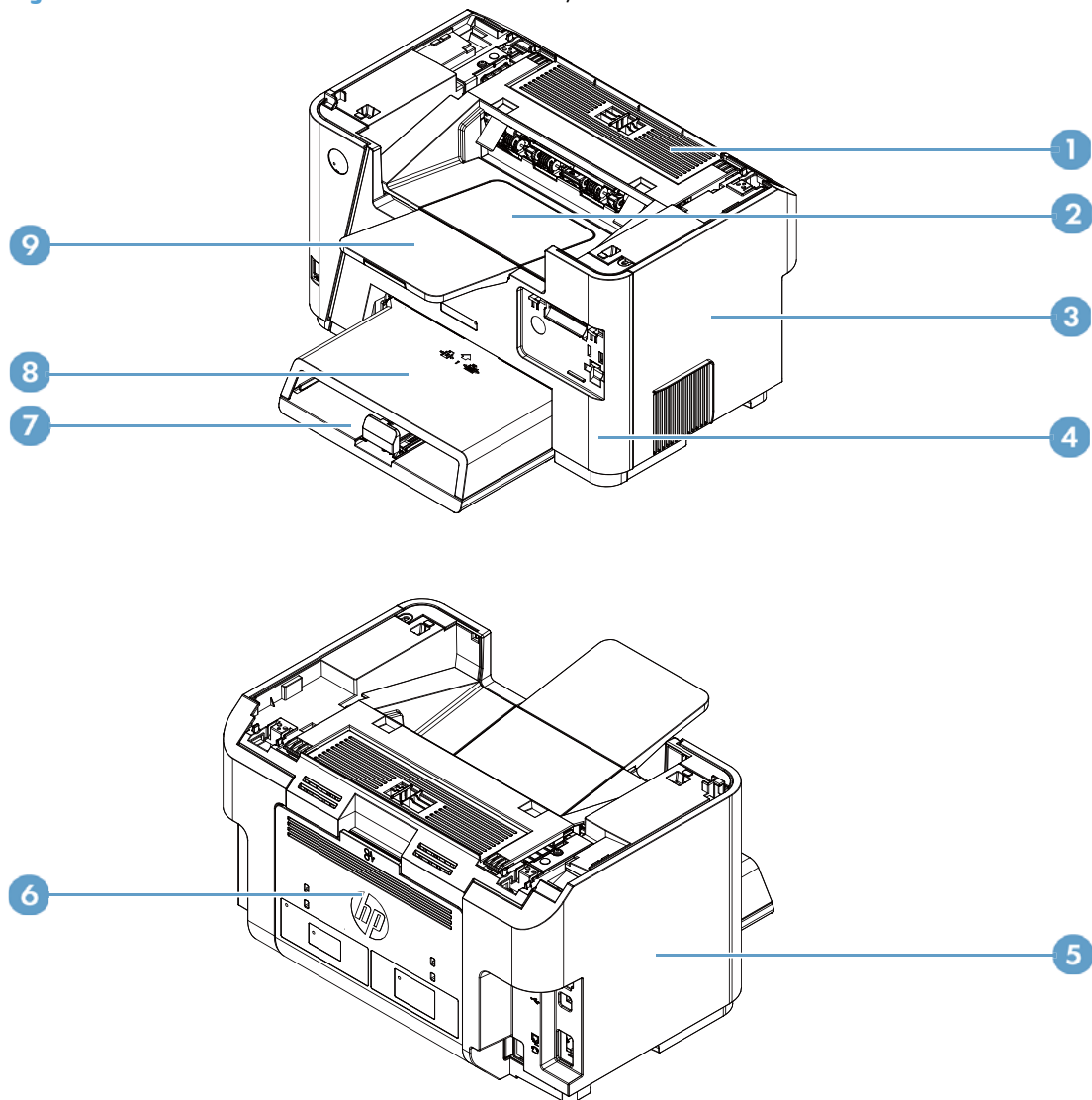

Table 1-3 Parts identification: LaserJet Pro MFP M225, M226

Item	Description
1	Top cover
2	Cartridge door
3	Right cover
4	Front cover assembly
5	Left cover
6	Duplex door assembly
7	Input tray assembly

Table 1-3 Parts identification: LaserJet Pro MFP M225, M226 (continued)

Item	Description
8	Dust cover
9	Output tray assembly
Not shown	Scanner/ADF assembly

Input and output tray assemblies (all models)

Dust cover

Release two shafts (callout 1) and remove the dust cover (callout 2).

Figure 1-46 Remove the dust cover (1 of 1)

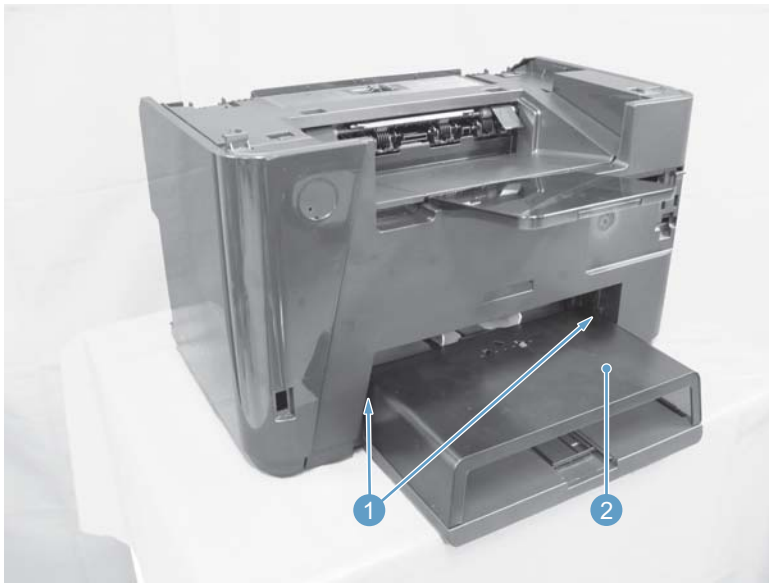

Input tray assembly

1. Remove the dust cover.
2. Pull the input tray assembly (callout 1) towards the front side of the printer and remove it.

Figure 1-47 Remove the input tray assembly (1 of 1)



Output tray assembly

Hold up the output tray assembly (callout 1) and remove it.

Figure 1-48 Remove the output tray assembly (1 of 1)



Left cover

1. Open the duplex door assembly.

2. Release four tabs (callout 1) and remove the left cover (callout 2).

Figure 1-49 Remove the left cover (1 of 1)

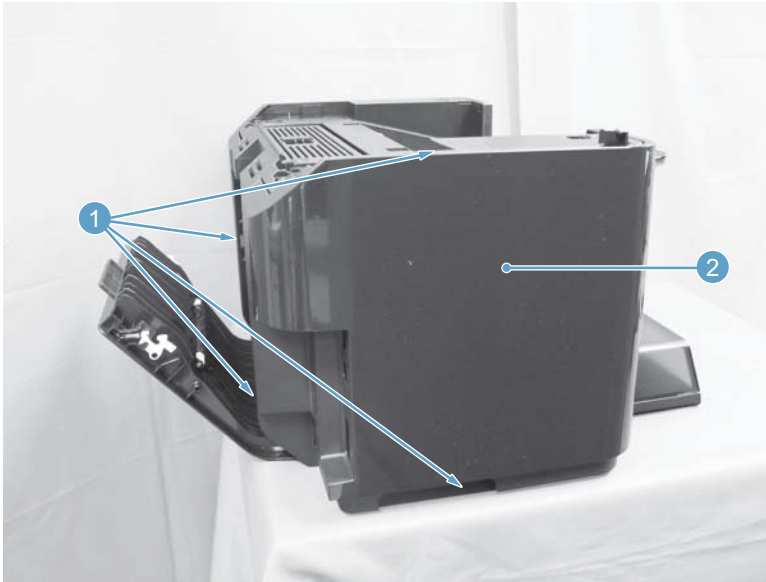

Front cover assembly

Before proceeding, remove the following components:

- Dust cover. See [Dust cover on page 36](#)
- Input tray assembly. See [Input tray assembly on page 36](#).
- Output tray assembly. See [Output tray assembly on page 37](#).
- Left cover. See [Left cover on page 37](#).

Remove the front cover assembly

1. Disconnect one FFC (callout 1) from the formatter.

Figure 1-50 Remove the front cover (1 of 3)

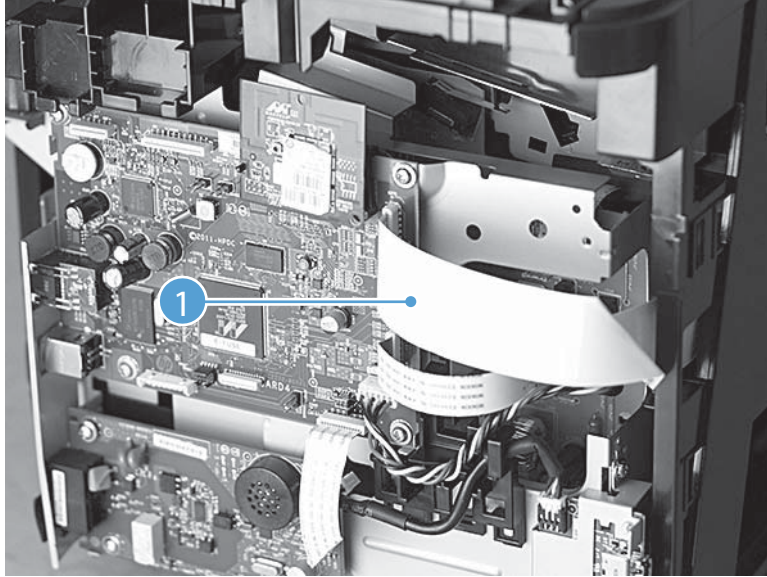

2. Remove three screws (callout 1), and then remove one screw (callout 2) to release the ground strap (callout 3).

Figure 1-51 Remove the front cover (2 of 3)

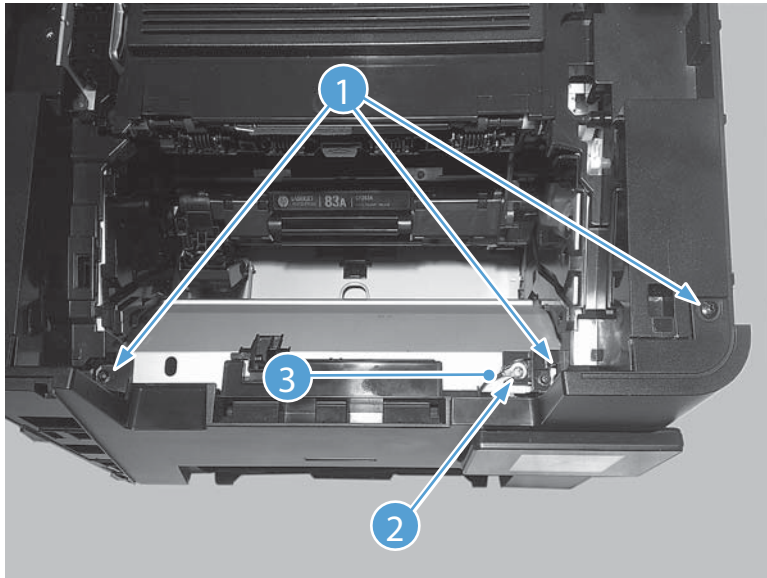

3. Release three tabs (callout 1), and then remove the front cover (callout 2).

Figure 1-52 Remove the front cover (3 of 3)

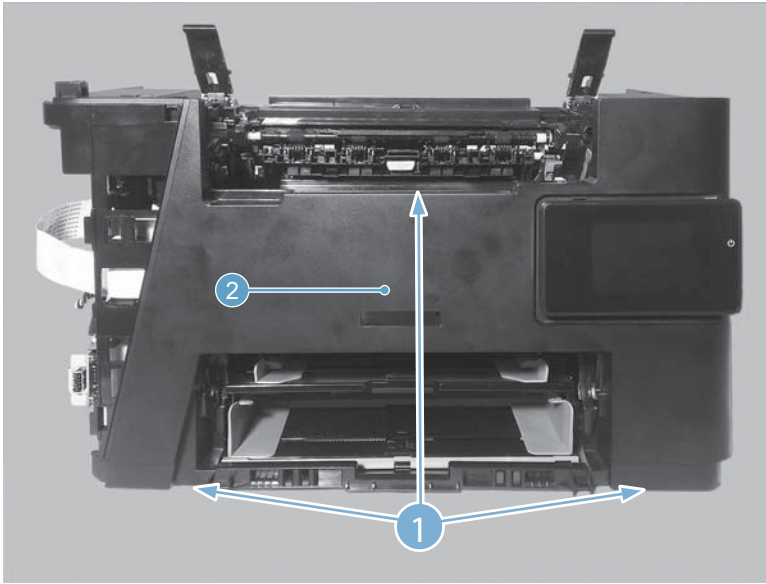

Right cover

Before proceeding, remove the following components:

- Dust cover. See [Dust cover on page 36](#)
- Input tray assembly. See [Input tray assembly on page 36](#).
- Output tray assembly. See [Output tray assembly on page 37](#).
- Left cover. See [Left cover on page 37](#).
- Front cover assembly. See [Front cover assembly on page 38](#).

Remove the right cover assembly

1. Remove one screw (callout 1).

Figure 1-53 Remove the right cover (1 of 3)



2. Release two tabs on the side of the product (callout 1).

Figure 1-54 Remove the right cover (2 of 3)

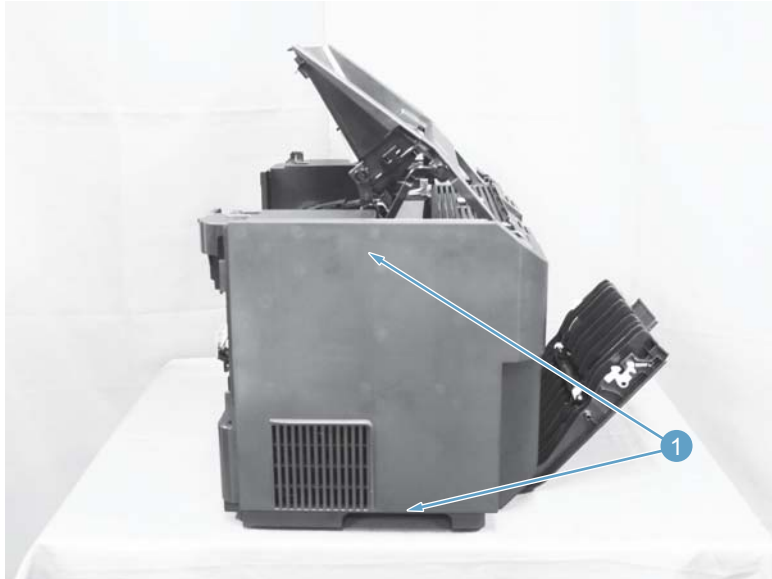

3. Release two tabs (callout 1) and remove the right cover (callout 2).

Figure 1-55 Remove the right cover (3 of 3)

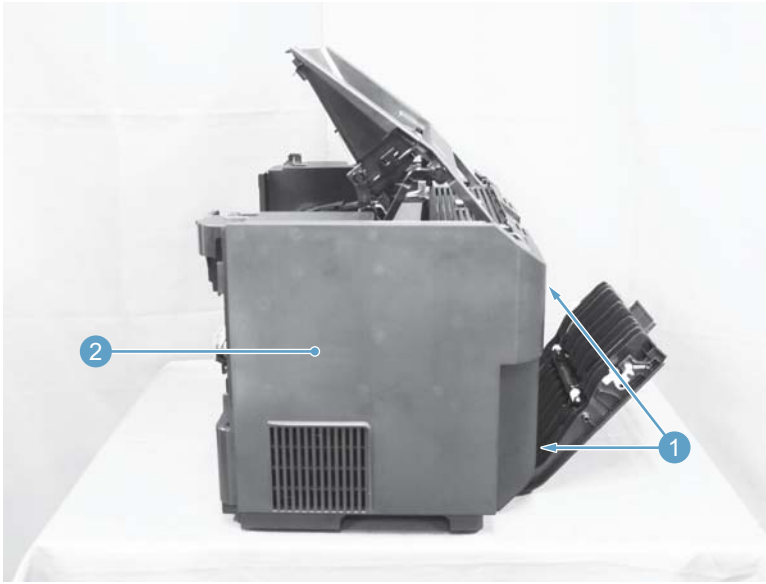

Scanner assembly

Before proceeding, remove the following component:

- Left cover. See [Left cover on page 37](#).

Remove the scanner assembly

1. Disconnect two FFCs (callout 1).

Figure 1-56 Remove the scanner assembly (1 of 4)

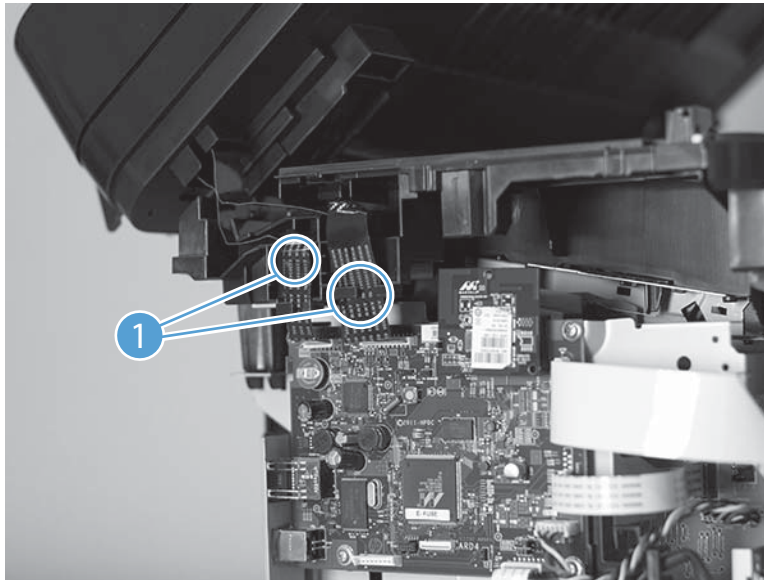

2. Carefully remove the two FFCs from the guides (callout 1).

Figure 1-57 Remove the scanner assembly (2 of 4)

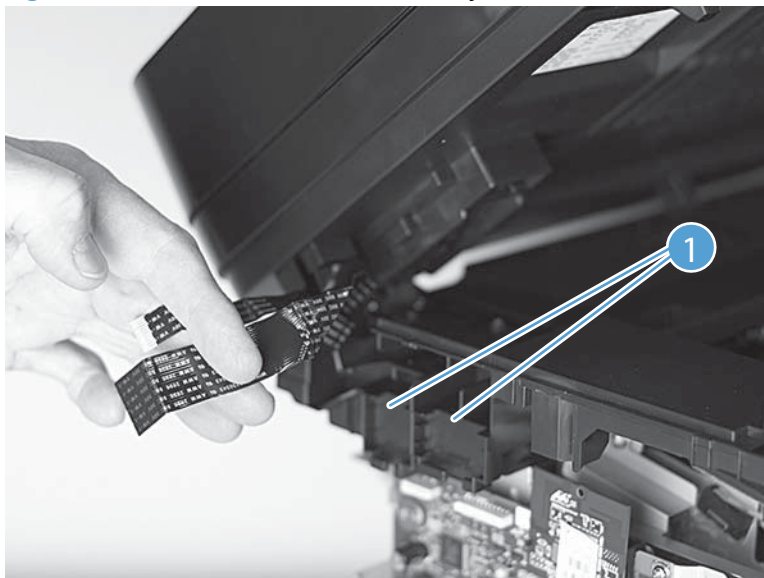

3. Release the tab inside each hinge (callout 1) to enable the scanner assembly to slide on the hinges.

Figure 1-58 Remove the scanner assembly (3 of 4)

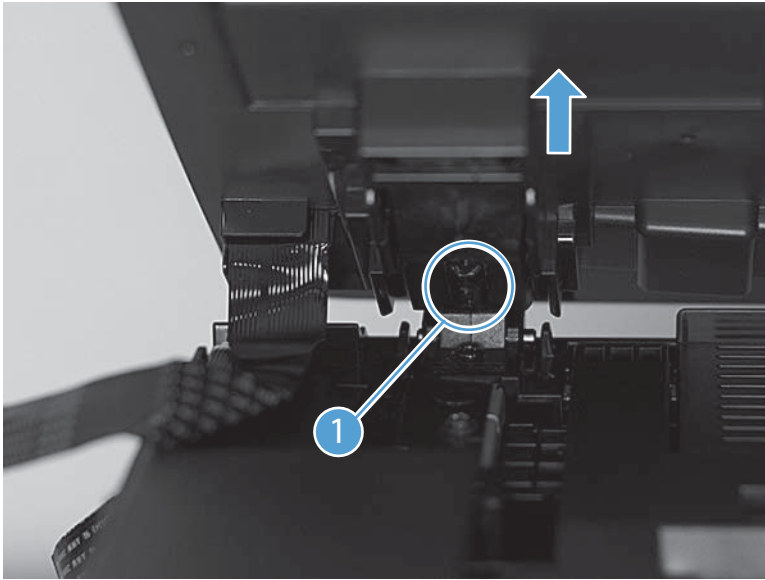

4. Lift the scanner assembly up (arrow 1) and away from the hinges (arrow 2).

Figure 1-59 Remove the scanner assembly (4 of 4)

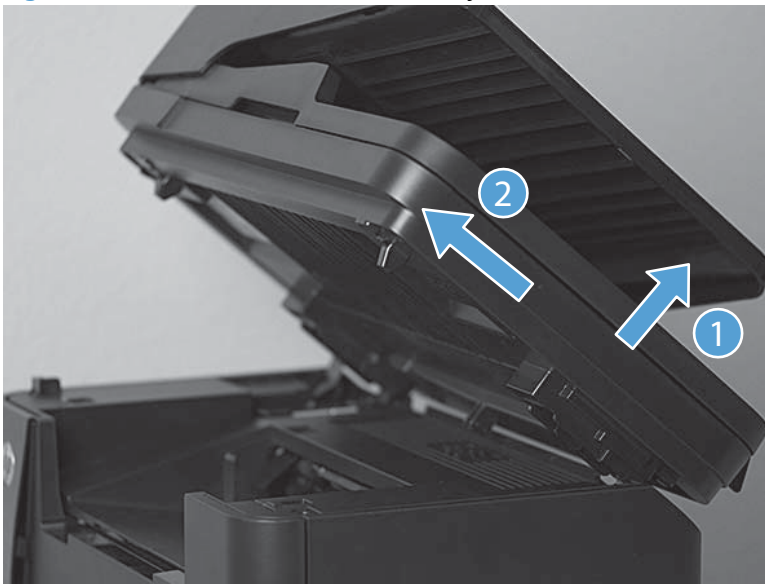

Scanner hinges

Before proceeding, remove the following components:

- Dust cover. See [Dust cover on page 36](#)
- Input tray assembly. See [Input tray assembly on page 36](#).
- Output tray assembly. See [Output tray assembly on page 37](#).
- Left cover. See [Left cover on page 37](#).
- Scanner assembly. See [Scanner assembly on page 43](#).

Remove the scanner hinges

1. Remove one screw (callout 1) from each hinge.

Figure 1-60 Remove the scanner hinges (1 of 2)

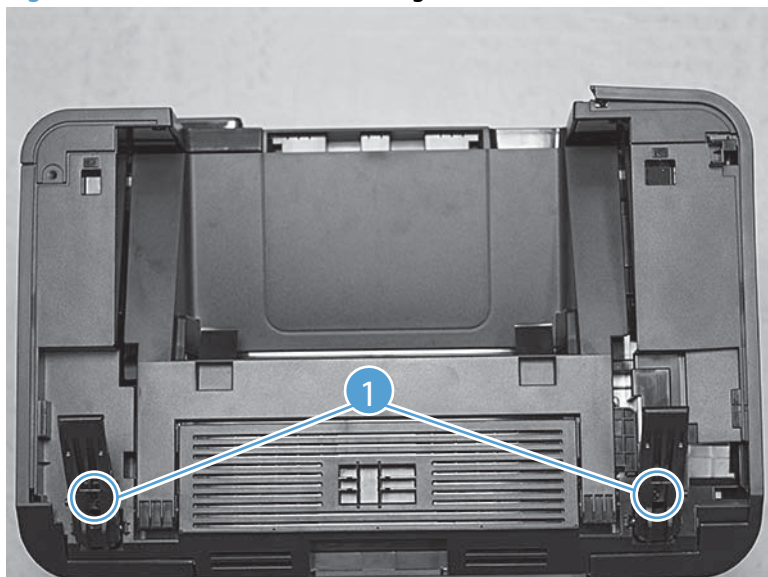

2. Lift each hinge up to remove it.

Figure 1-61 Remove the scanner hinges (2 of 2)



Duplex door and duplex frame

Duplex door

- ▲ Release two shafts (callout 1) and remove the duplex door ass'y (callout 2).

Figure 1-62 Remove the duplex door assembly (1 of 1)

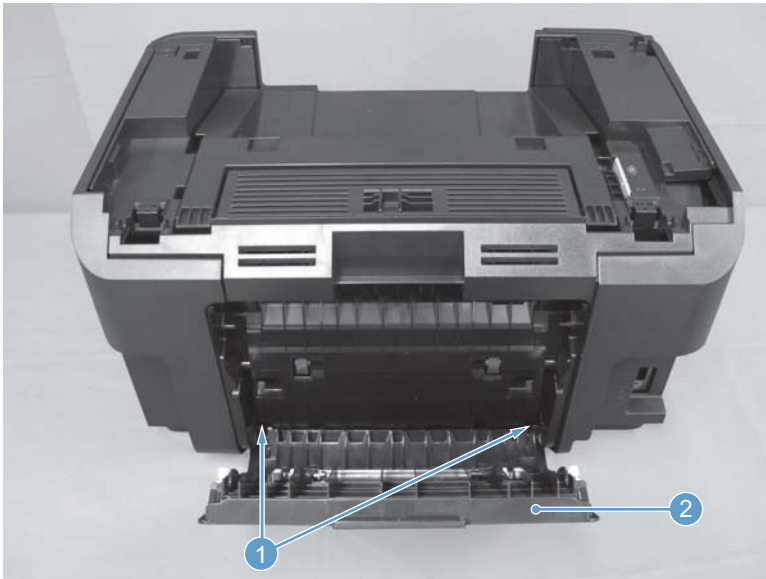

Duplex frame

Before proceeding, remove the following components:

- Left cover. See [Left cover on page 37](#).
- Right cover. See [Right cover on page 40](#).
- Scanner assembly. See [Scanner assembly on page 43](#).
- Top cover cap. See [Top cover cap on page 50](#).
- Duplex door. See [Duplex door on page 46](#).

Remove the duplex frame

1. Release two tabs (callout 1), and then remove the duplex reverse guide (callout 2).

Figure 1-63 Remove the duplex frame (1 of 2)

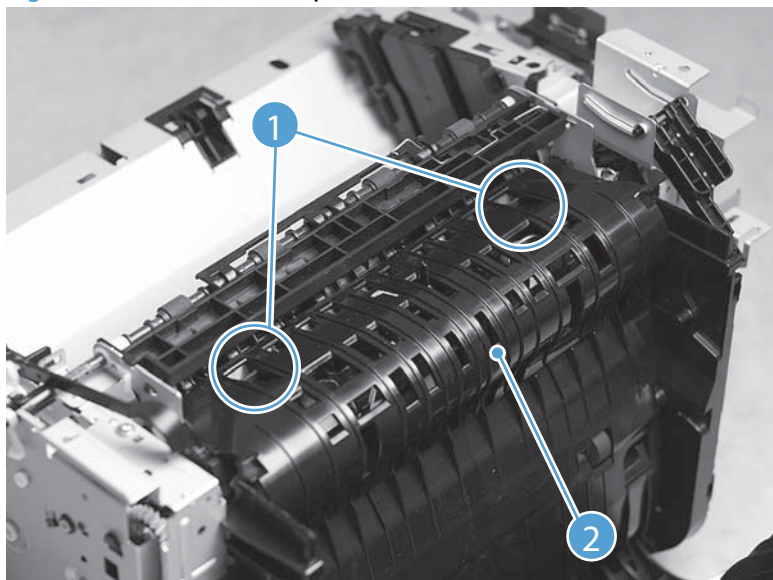

2. Remove four screws (callout 1), and then remove the duplex frame (callout 2).

Figure 1-64 Remove the duplex frame (2 of 2)

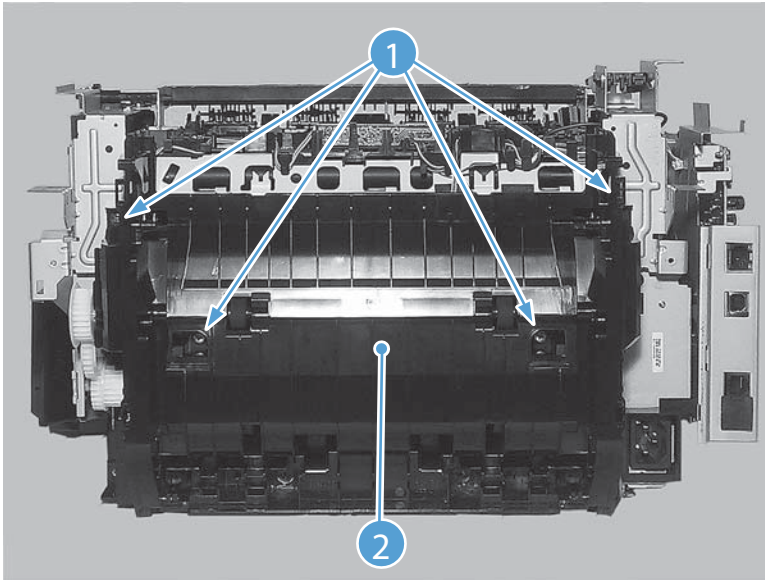

Cartridge door

Before proceeding, remove the following components:

- Dust cover. See [Dust cover on page 36](#)
- Input tray assembly. See [Input tray assembly on page 36](#).
- Output tray assembly. See [Output tray assembly on page 37](#).
- Left cover. See [Left cover on page 37](#).
- Front cover assembly. See [Front cover assembly on page 38](#).
- Right cover. See [Right cover on page 40](#).
- Top cover. See [Top cover cap on page 50](#).

Remove the cartridge door

1. Release four tabs (callout 1).

Figure 1-65 Remove the cartridge door (1 of 3)

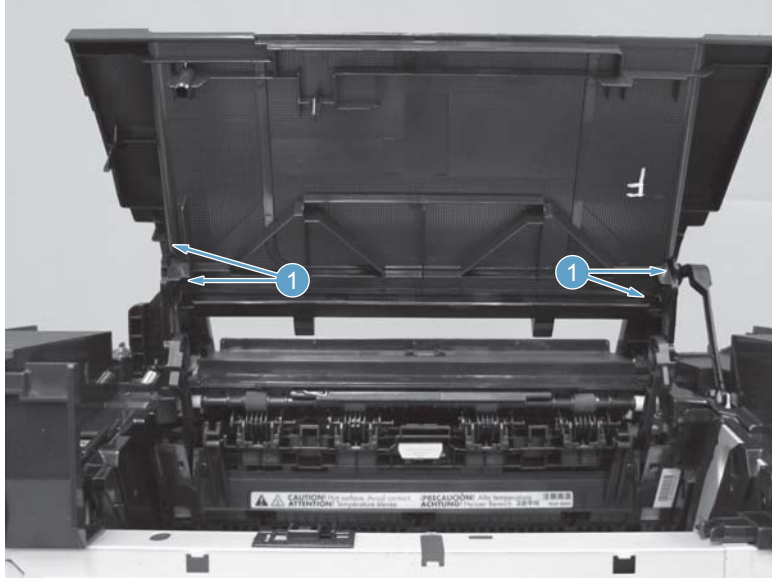

2. Release two link arms on the left side (callout 1) and two link arms on the right side (callout 2).

Figure 1-66 Remove the cartridge door (2 of 3)



3. Remove the cartridge door (callout 1).

Figure 1-67 Remove the cartridge door (3 of 3)



Top cover cap

Before proceeding, remove the following components:

- Dust cover. See [Dust cover on page 36](#)
- Input tray assembly. See [Input tray assembly on page 36](#).
- Output tray assembly. See [Output tray assembly on page 37](#).
- Left cover. See [Left cover on page 37](#).
- Front cover assembly. See [Front cover assembly on page 38](#).
- Right cover. See [Right cover on page 40](#).
- Cartridge door. See [Cartridge door on page 48](#).

Remove the top cover cap

- ▲ Remove four screws (callout 1) and the top cover (callout 2).

Figure 1-68 Remove the top cover (1 of 1)

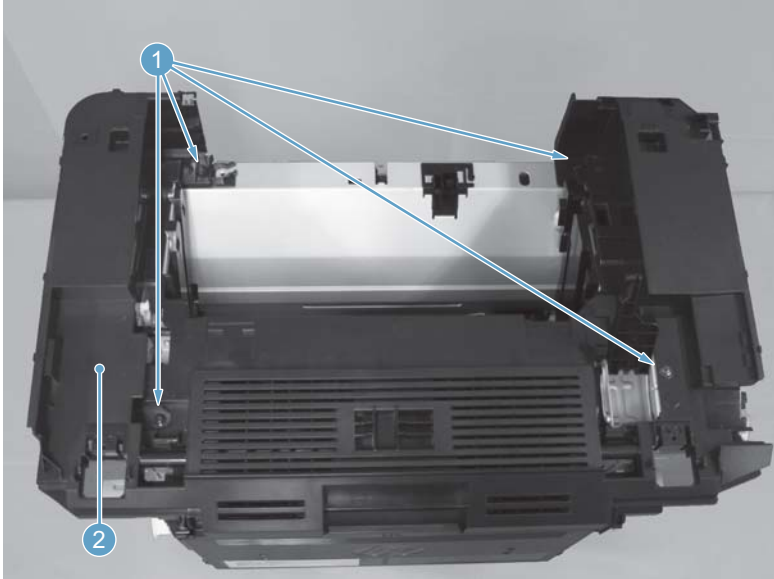

Top cover

Before proceeding, remove the following components:

- Main-input tray. See [Input tray assembly on page 36](#).
- Output bin tray extension. See [Output tray assembly on page 37](#).
- Left cover. See [Left cover on page 37](#).
- Front cover. See [Front cover assembly on page 38](#).
- Right cover. See [Right cover on page 40](#).
- Cartridge door. See [Cartridge door on page 48](#).

Remove the top cover

1. Remove two screws (callout 1).

CAUTION: The upper-cartridge door arms (callout 2) can become easily be dislodged from the lower arms. Do not lose the upper-cartridge door arms while servicing the product.

Figure 1-69 Remove the top cover (1 of 2)

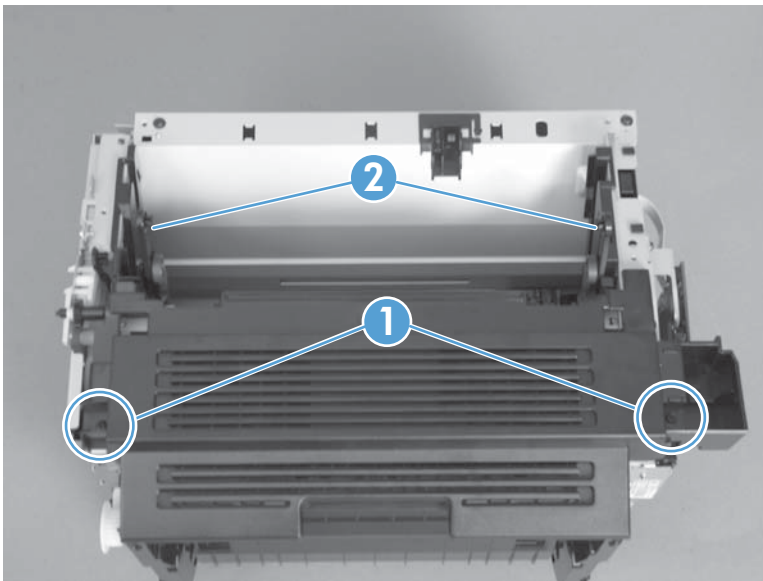

2. Lift the cover up and off the product to remove it.

Figure 1-70 Remove the top cover (2 of 2)

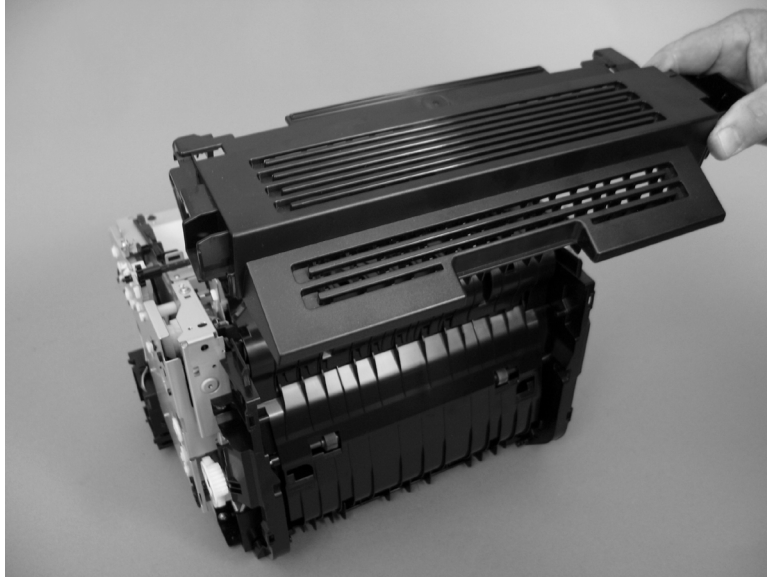

Transfer roller

⚠ CAUTION: Do not touch the sponge portion of the roller. Skin oils can cause print quality problems.

1. Open the print-cartridge door.
2. Release two tabs (callout 1), and then remove the transfer roller (callout 2).

Figure 1-71 Remove the transfer roller

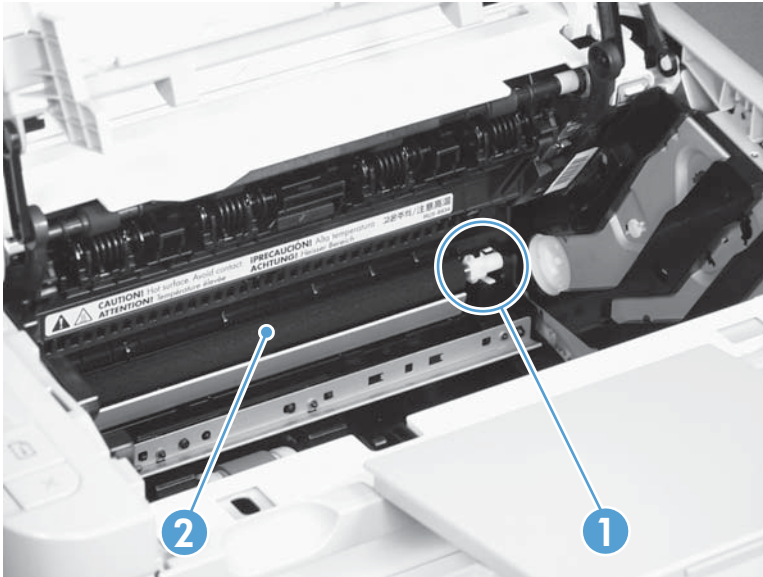

Internal assemblies

Formatter PCA

1. Remove the left cover. See [Left cover, duplex product on page 12](#) or [Left cover, simplex product on page 13](#) or [Left cover on page 37](#).

2. Disconnect two FFCs (callout 1) and two connectors (callout 2), and then disconnect two FFCs (callout 3 – MFP models only).

Figure 1-72 Remove the formatter PCA (1 of 2)

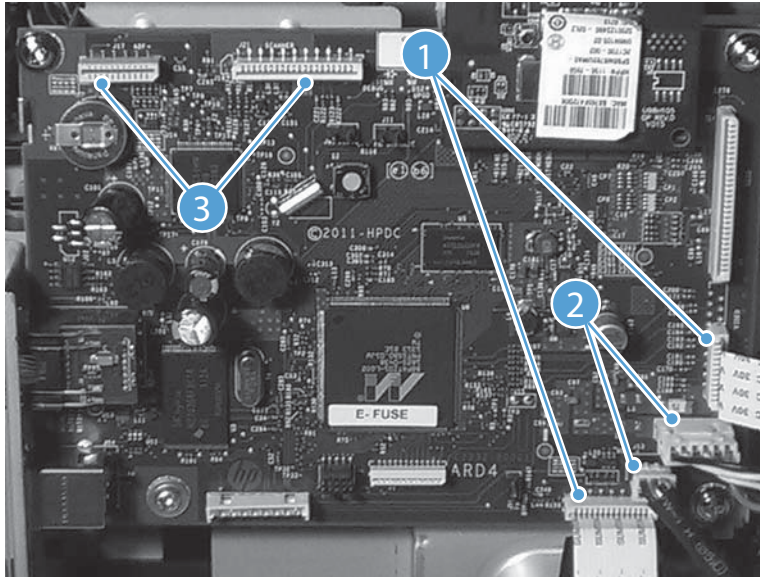

3. Remove four screws (callout 1), and then remove the formatter PCA (callout 2).

Figure 1-73 Remove the formatter PCA (2 of 2)

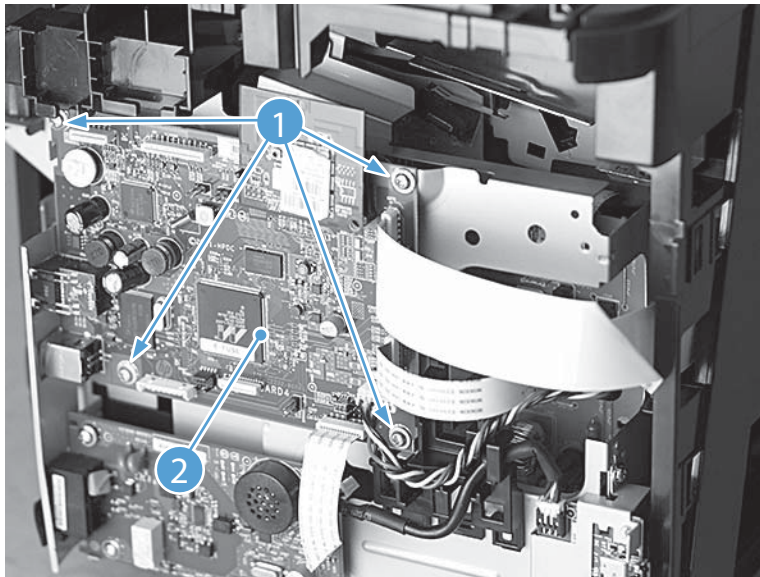

Fuser

Before proceeding, remove the following components:

- Dust cover. See [Dust cover on page 11](#) or [Dust cover on page 36](#)
- Input tray assembly. See [Input tray assembly on page 11](#) or [Input tray assembly on page 36](#).
- Output tray assembly. See [Output tray assembly on page 11](#) or [Output tray assembly on page 37](#).
- Left cover. See [Left cover, duplex product on page 12](#) or [Left cover, simplex product on page 13](#) or [Left cover on page 37](#).
- Front cover assembly. See [Front cover assembly on page 15](#) or [Front cover assembly on page 38](#).
- Right cover. See [Right cover, duplex product on page 16](#) or [Right cover, simplex product on page 18](#) or [Right cover on page 40](#).
- Rear cover (simplex product) or duplex door (duplex product). See [Rear cover, simplex product on page 22](#) or [Duplex door, duplex product on page 20](#) or [Duplex door on page 46](#).
- Duplex frame (duplex products only). See [Duplex frame, duplex product on page 21](#) or [Duplex frame on page 47](#).
- Cartridge door. See [Cartridge door, duplex product on page 29](#) or [Cartridge door, simplex product on page 23](#) or [Cartridge door on page 48](#).
- Top cover. See [Top cover on page 33](#) or [Top cover on page 52](#).
- Formatter PCA. See [Formatter PCA on page 54](#)

Remove the fuser

1. **Duplex models only:** Release two tabs (callout 1), and then remove the duplex reverse guide (callout 2).

Figure 1-74 Remove the fuser (1 of 10)

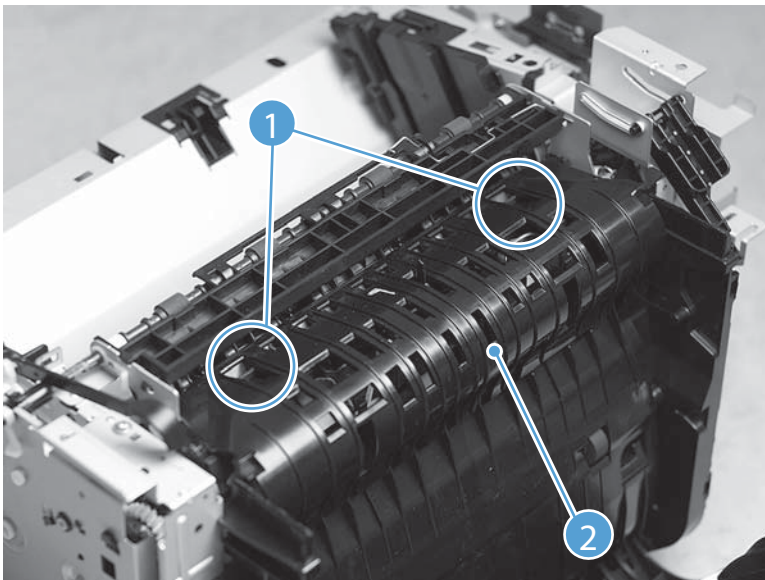

2. Remove two screws (callout 1), and then remove the sheet-metal corner brace (callout 2).

Figure 1-75 Remove the fuser (2 of 10)

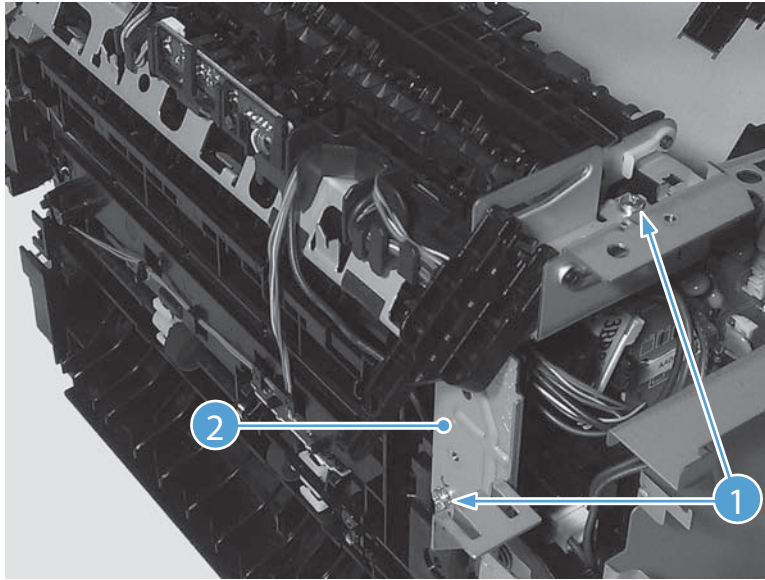

3. Remove one FFC (callout 1), remove four screws (callout 2), and then remove the fax PCA (callout 3).

Figure 1-76 Remove the fuser (3 of 10)

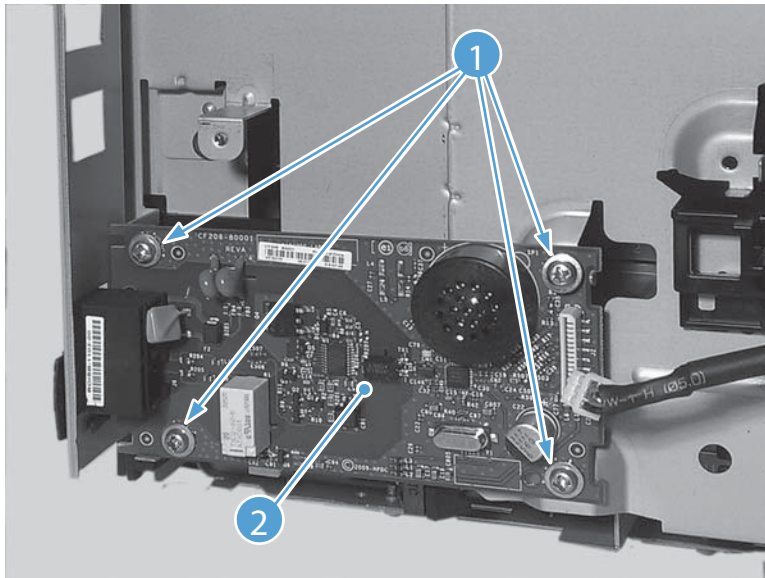

4. Remove five screws (callout 1), and then remove the sheet-metal plate (callout 2).

Figure 1-77 Remove the fuser (4 of 10)

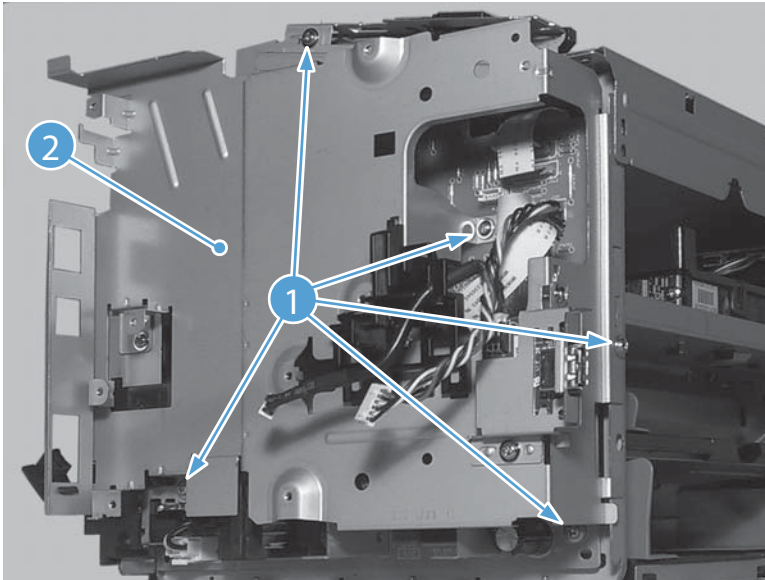

5. Disconnect one connector (callout 1), and then release the wire harness (callout 2) from the guide (callout 3).

Figure 1-78 Remove the fuser (5 of 10)

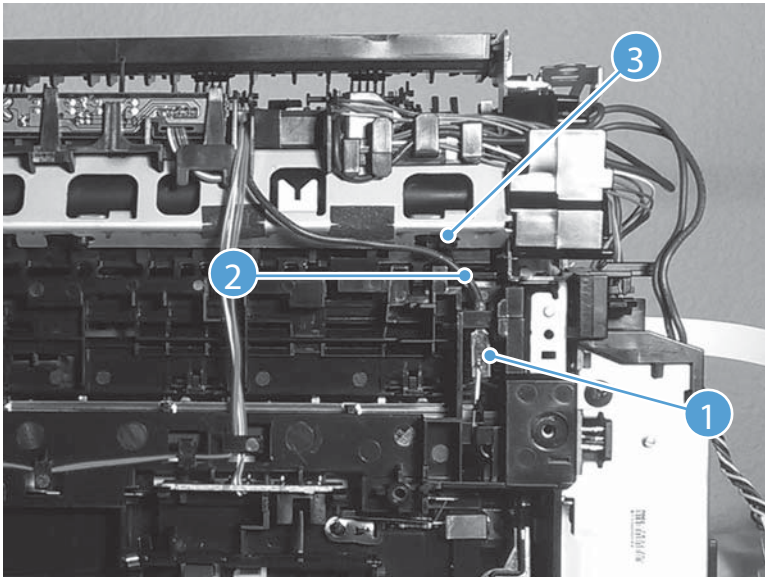

6. Disconnect four connectors (callout 1), and then release the wire harnesses (callout 2) from the guide (callout 3).

Figure 1-79 Remove the fuser (6 of 10)

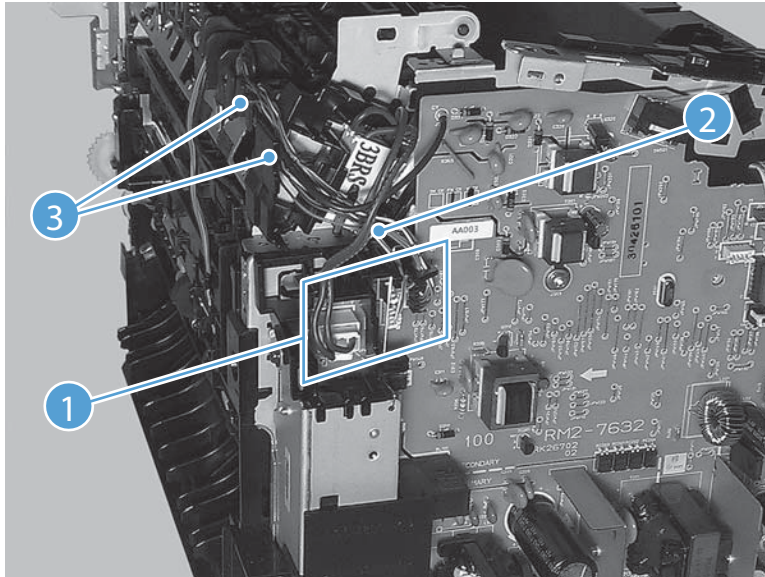

7. Disconnect one tab (callout 1), and then remove the guide (callout 2).

Figure 1-80 Remove the fuser (7 of 10)

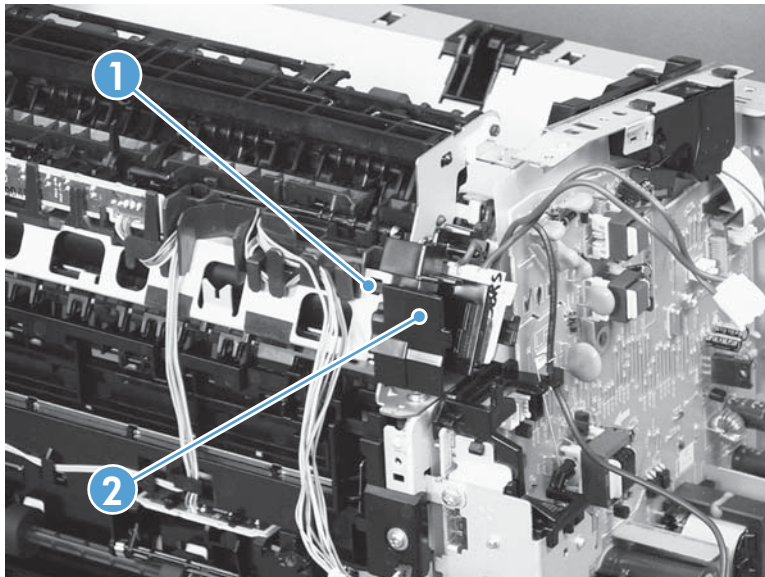

8. Release the wire harnesses (callout 1) from the guide (callout 2).

Figure 1-81 Remove the fuser (8 of 10)

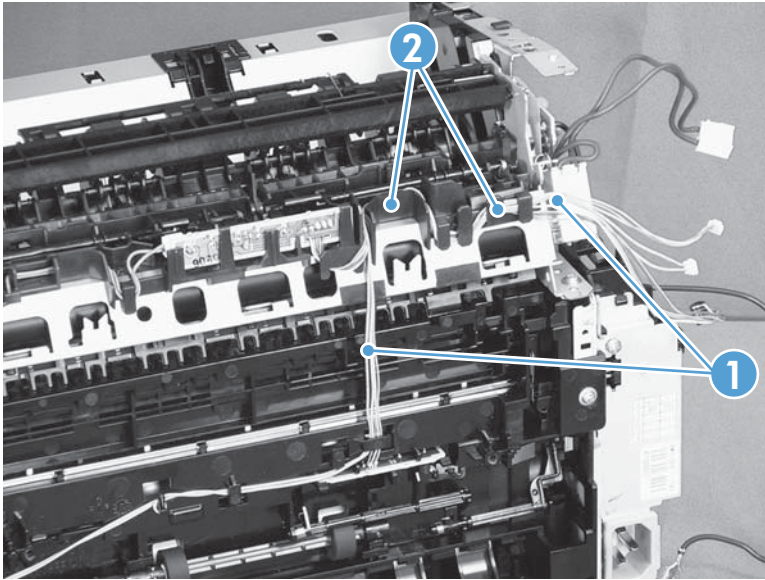

9. On the right side of the product, remove two screws (callout 1) and the sheet-metal brace (callout 2), and then remove one bushing (callout 3).

Figure 1-82 Remove the fuser (9 of 10)

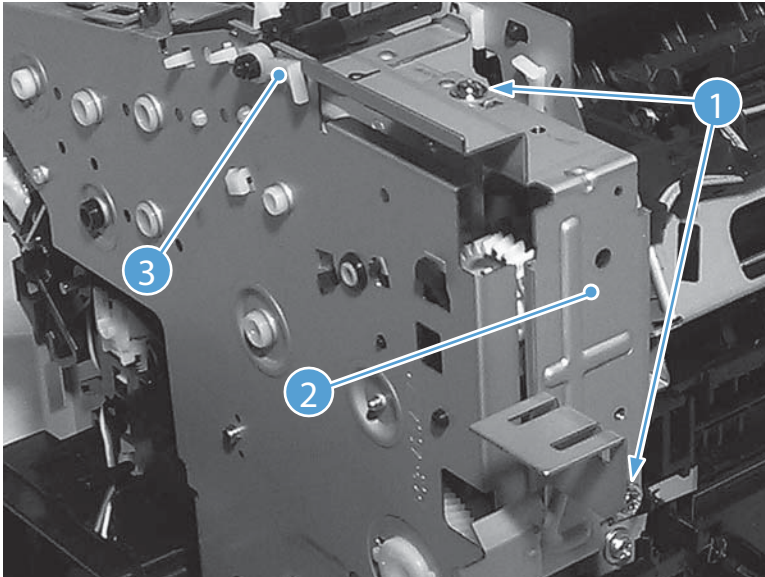

10. Remove three screws (callout 1) and then remove the fuser (callout 2).

Figure 1-83 Remove the fuser (10 of 10)

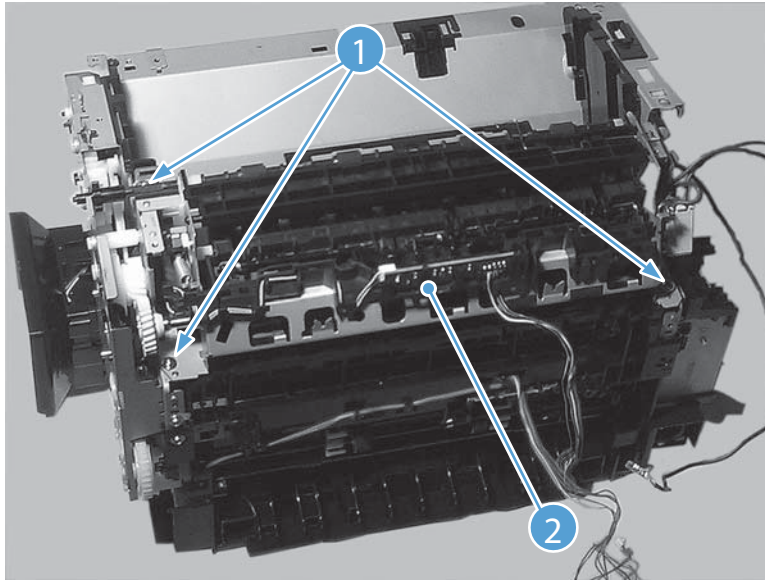

Reinstall the fuser

- ▲ To avoid damage to the wire harnesses, make sure that they are correctly installed in the guides when the fuser is reinstalled.

Figure 1-84 Reinstall the fuser; correct wire harness installation

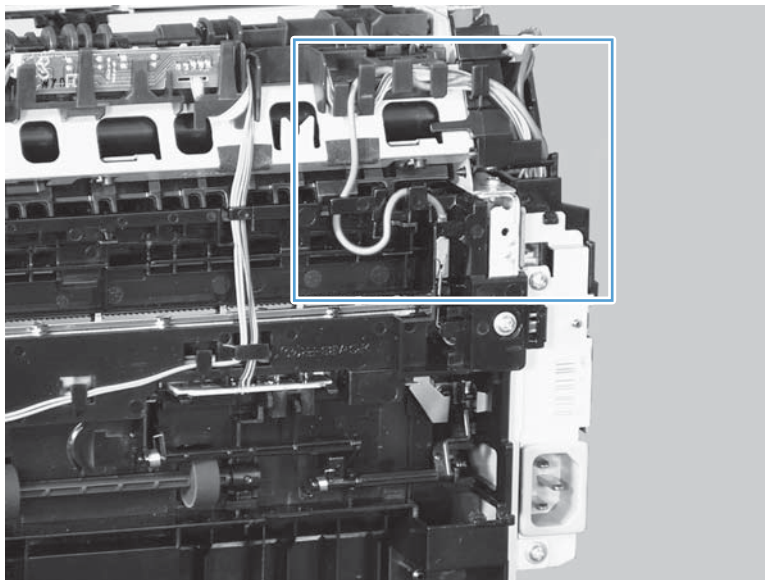
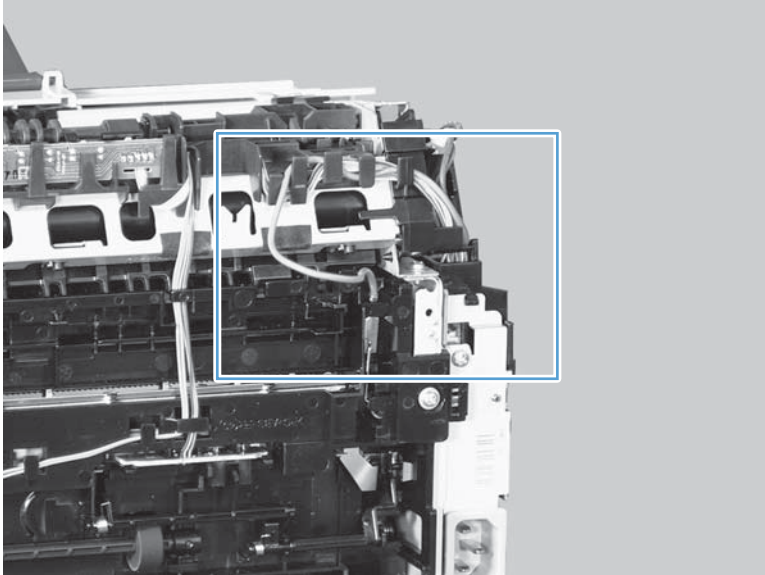



Figure 1-85 Reinstall the fuser; incorrect wire harness installation



Main assemblies

 **NOTE:** Some photos in this section show components that might not be installed or removed from your product; however, the procedures for replacement and repair in this chapter are correct for your product.

Fuser film assembly

Remove the fuser film assembly

1. Remove the fuser. See [Fuser on page 56](#).
2. Disconnect one connector (callout 1), then release the cables (callout 2) from the cable guide (callout 3).

Figure 1-86 Remove the fuser film assembly (1 of 4)

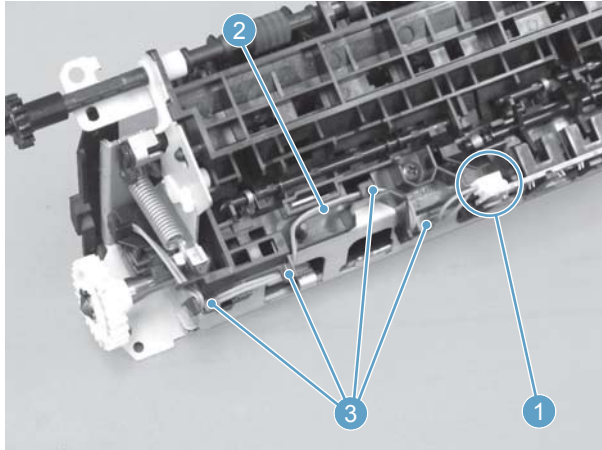

3. Remove two screws (callout 1).

Figure 1-87 Remove the fuser film assembly (2 of 4)

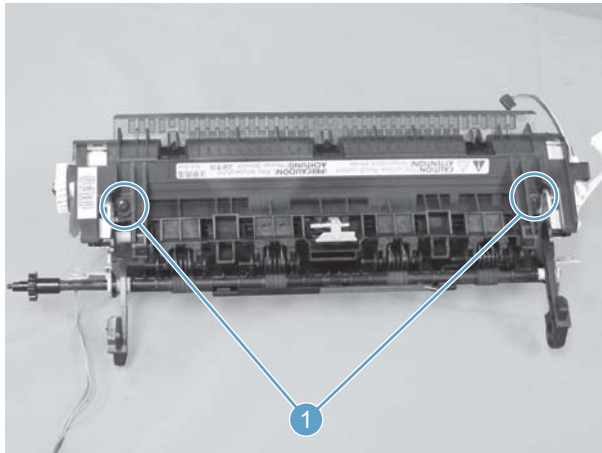

4. Remove the fuser cover (callout 1).

Figure 1-88 Remove the fuser film assembly (3 of 4)

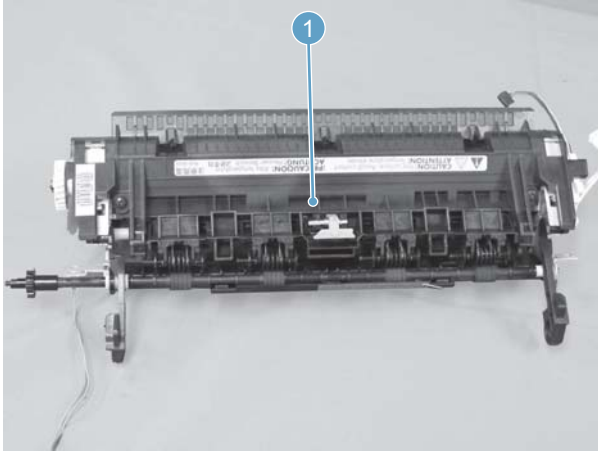

5. Examine the assembly and locate the components in [Table 1-4 Fuser film assembly components on page 65](#).

Figure 1-89 Fuser film assembly overview

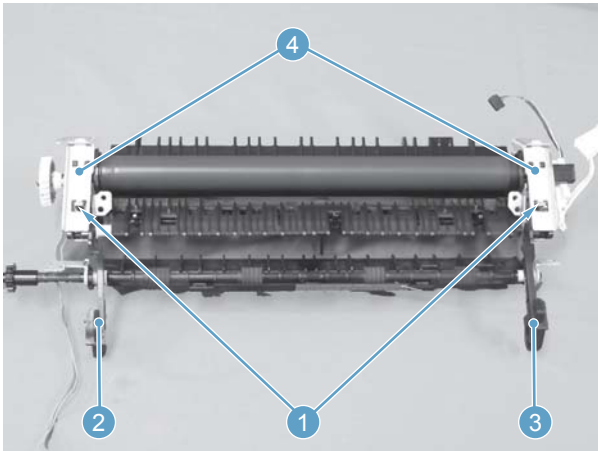

Figure 1-90 Fuser film assembly left side detail

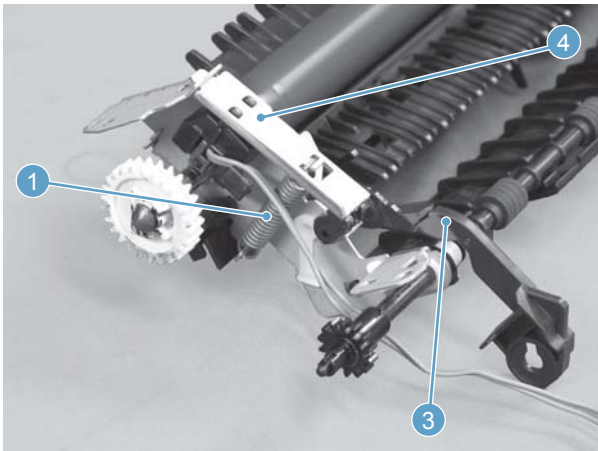

Figure 1-91 Fuser film assembly right side detail

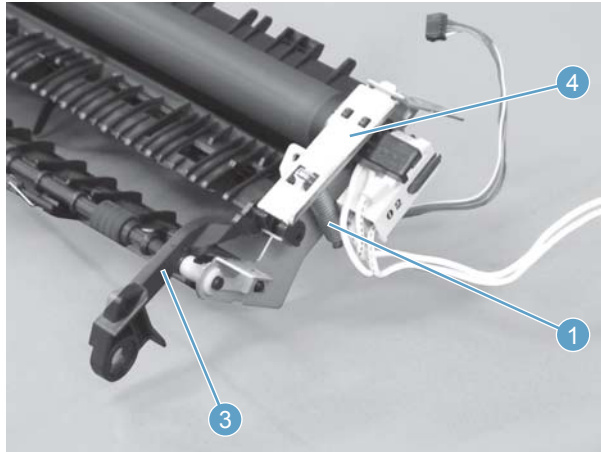
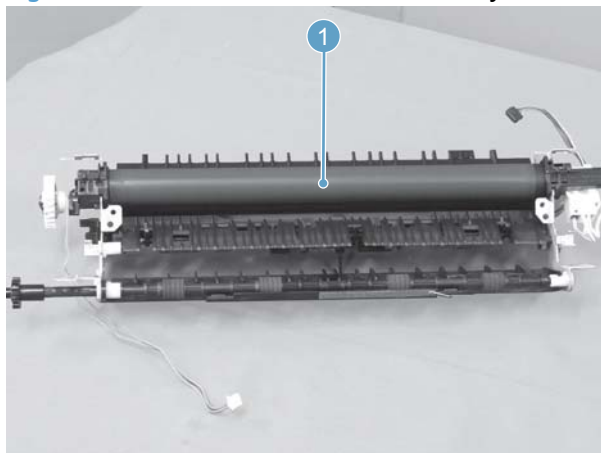

Table 1-4 Fuser film assembly components

Item	Description
1	Left and right springs
2	Left pressure release lever
3	Right pressure release lever
4	Left and right pressure plates

6. Remove two springs (callout 1).
7. Remove one left pressure release lever (callout 2).
8. Remove one right pressure release lever (callout 3).
9. Remove two pressure plates (callout 4).
10. Remove the fuser film assembly (callout 1).

Figure 1-92 Remove the fuser film assembly (4 of 4)



The shape of the pressure release lever is different between the products.

Figure 1-93 Pressure release levers, LaserJet Pro M201 and M202 series

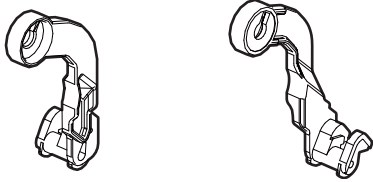
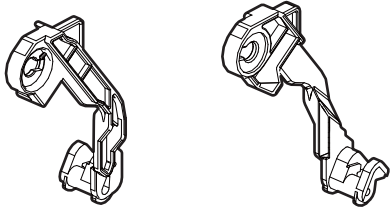

Figure 1-94 Pressure release levers, LaserJet Pro MFP M225 and M226 series



Reinstall the fuser film assembly

Content for this section was not provided.

Laser/scanner assembly

Before proceeding, remove the following components:

- Dust cover. See [Dust cover on page 11](#) or [Dust cover on page 36](#)
- Input tray assembly. See [Input tray assembly on page 11](#) or [Input tray assembly on page 36](#).
- Output tray assembly. See [Output tray assembly on page 11](#) or [Output tray assembly on page 37](#).
- Left cover. See [Left cover, duplex product on page 12](#) or [Left cover, simplex product on page 13](#) or [Left cover on page 37](#).
- Front cover assembly. See [Front cover assembly on page 15](#) or [Front cover assembly on page 38](#).
- Right cover. See [Right cover, duplex product on page 16](#) or [Right cover, simplex product on page 18](#) or [Right cover on page 40](#).

Remove the laser/scanner assembly

1. Release one tab (callout 1), and then remove the holder (callout 2).

Figure 1-95 Remove the laser/scanner assembly (1 of 5)

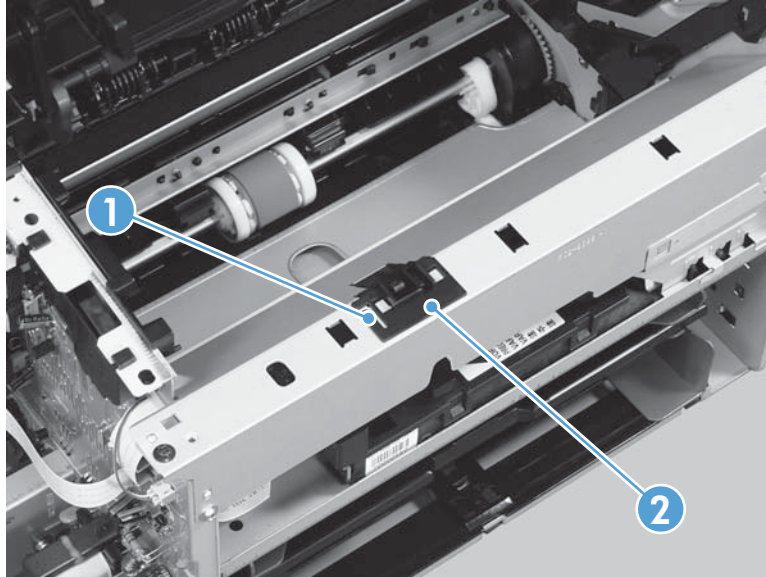

2. Remove four screws (callout 1), and then remove the scanner cover (callout 2) and the sheet-metal plate (callout 3) together.

CAUTION: The scanner cover (callout 2) and sheet-metal plate (callout 3) can be easily separated. Do not lose the plate while servicing the product.

TIP: When the cover is reinstalled, make sure that the black screws (callout 4) are installed in the correct screw holes.

Figure 1-96 Remove the laser/scanner assembly (2 of 5)

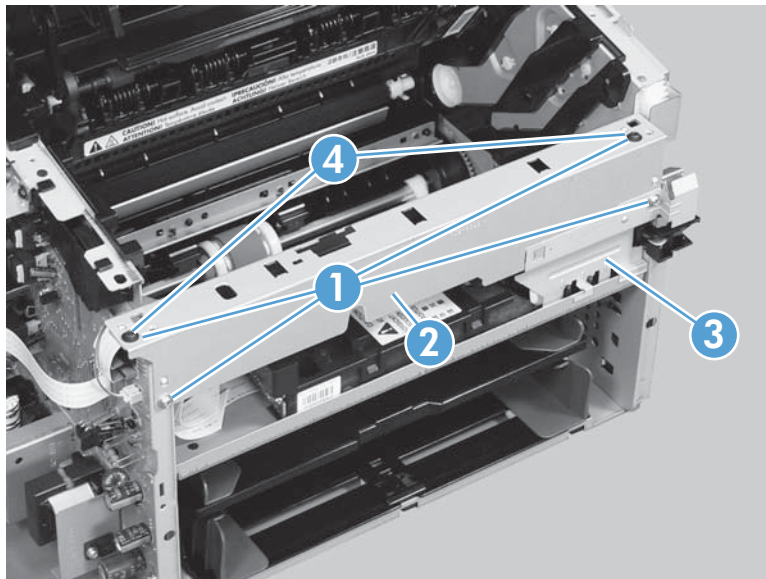

3. Disconnect one FFC (callout 1), and then remove four screws (callout 2).

Figure 1-97 Remove the laser/scanner assembly (3 of 5)

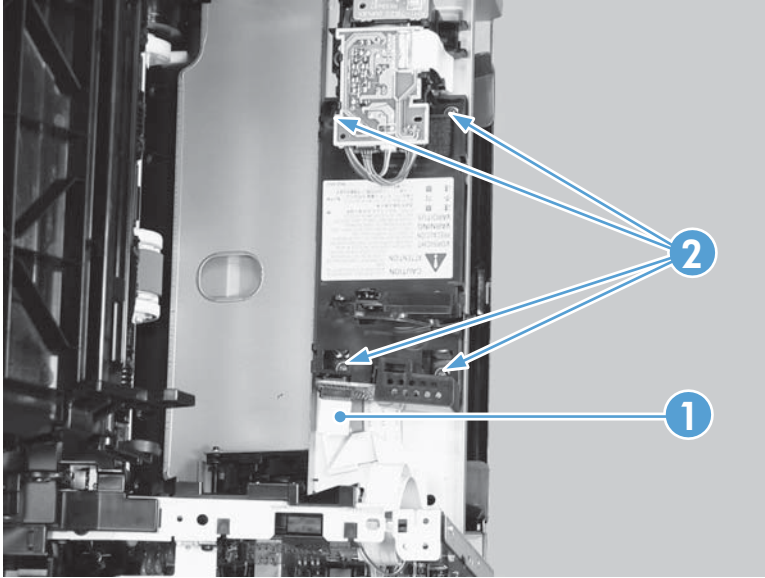

4. Remove the dust-proof sponge (callout 1).

Figure 1-98 Remove the laser/scanner assembly (4 of 5)

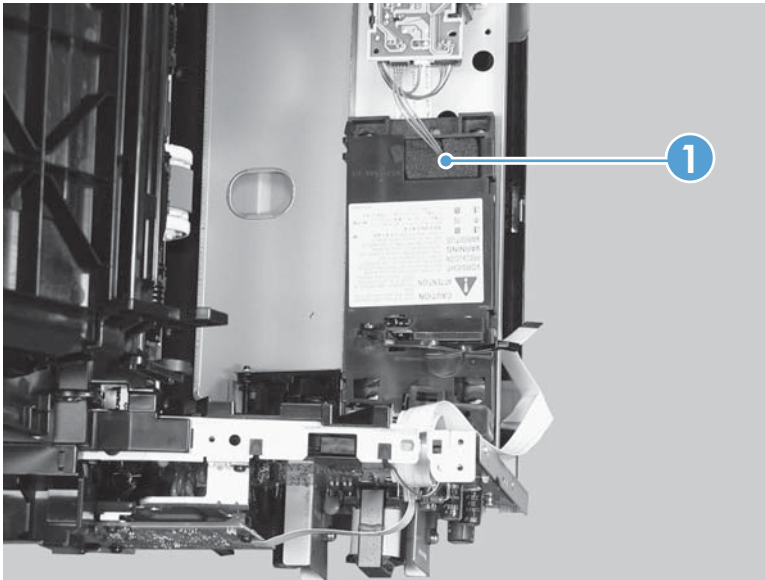

5. Disconnect one connector (callout 1), and then remove the laser/scanner assembly (callout 2).

Figure 1-99 Remove the laser/scanner assembly (5 of 5)

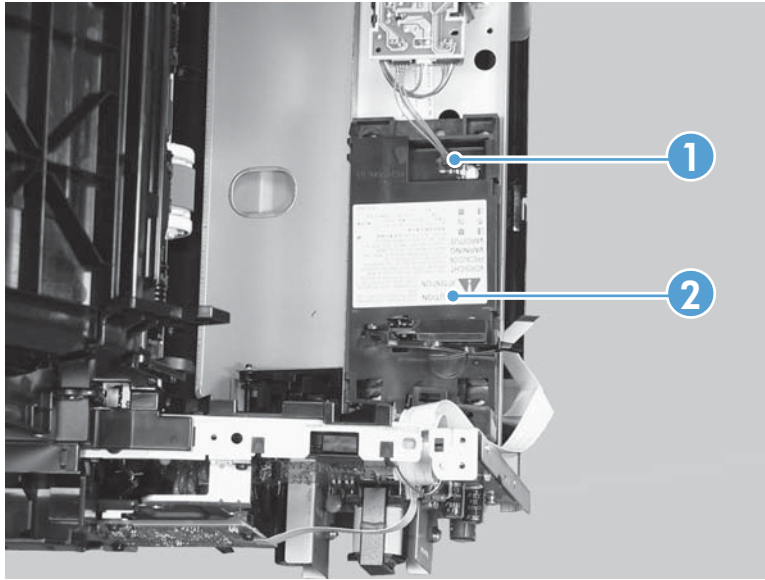

Reinstall the laser/scanner assembly

- ▲ When the holder is reinstalled (callout 1), make sure that the lever arm (callout 2) is correctly positioned in the slot in the holder.

Figure 1-100 Reinstall the laser/scanner assembly

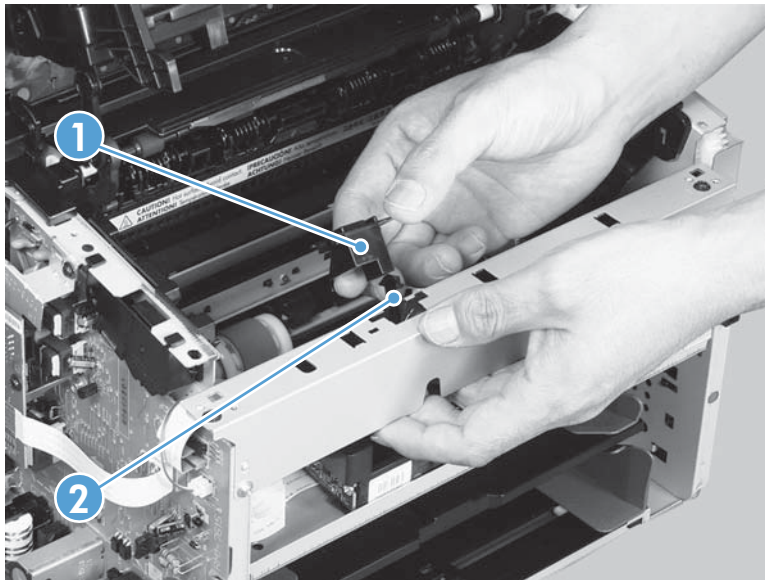

Pickup assembly

Before proceeding, remove the following components:

- Separation pad. See [Separation pad on page 9](#).
- Dust cover. See [Dust cover on page 11](#) or [Dust cover on page 36](#)
- Input tray assembly. See [Input tray assembly on page 11](#) or [Input tray assembly on page 36](#).
- Output tray assembly. See [Output tray assembly on page 11](#) or [Output tray assembly on page 37](#).
- Left cover. See [Left cover, duplex product on page 12](#) or [Left cover, simplex product on page 13](#) or [Left cover on page 37](#).
- Front cover assembly. See [Front cover assembly on page 15](#) or [Front cover assembly on page 38](#).
- Right cover. See [Right cover, duplex product on page 16](#) or [Right cover, simplex product on page 18](#) or [Right cover on page 40](#).
- Rear cover (simplex product) or duplex door (duplex product). See [Rear cover, simplex product on page 22](#) or [Duplex door, duplex product on page 20](#) or [Duplex door on page 46](#).
- Duplex frame (duplex products only). See [Duplex frame, duplex product on page 21](#) or [Duplex frame on page 47](#).
- Cartridge door. See [Cartridge door, duplex product on page 29](#) or [Cartridge door, simplex product on page 23](#) or [Cartridge door on page 48](#).
- Top cover. See [Top cover on page 33](#) or [Top cover on page 52](#).
- Formatter PCA. See [Formatter PCA on page 54](#)

Remove the pickup assembly

1. **Duplex models only:** Release two tabs (callout 1), and then remove the duplex reverse guide (callout 2).

Figure 1-101 Remove the pickup assembly (1 of 10)

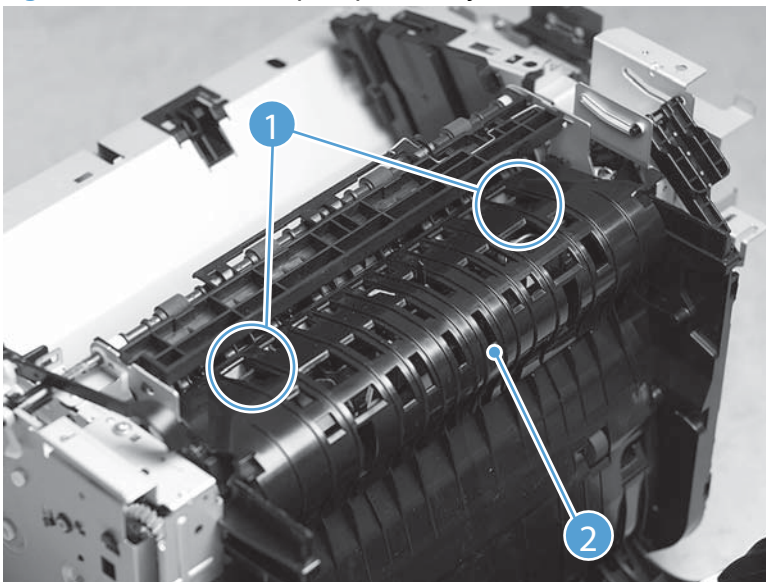

2. Remove two screws (callout 1), and then remove the sheet-metal corner brace (callout 2).

Figure 1-102 Remove the pickup assembly (2 of 10)

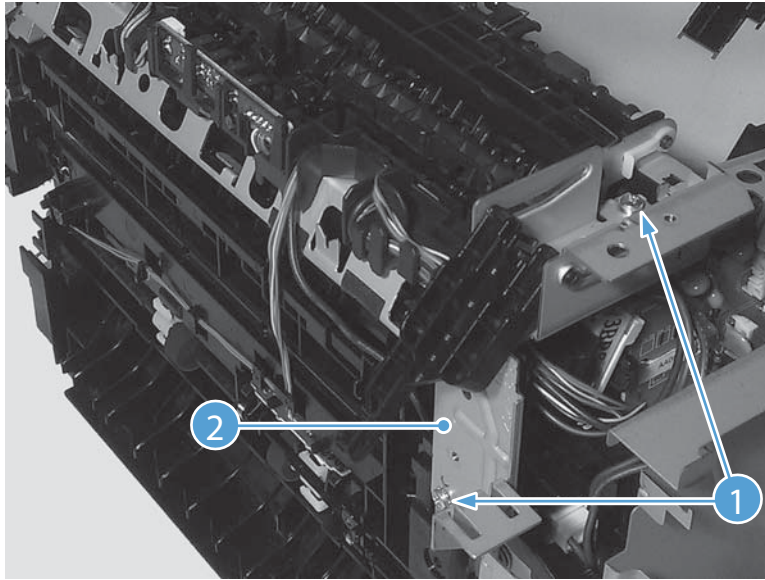

3. Remove one FFC (callout 1), remove four screws (callout 2), and then remove the fax PCA (callout 3).

Figure 1-103 Remove the pickup assembly (3 of 10)

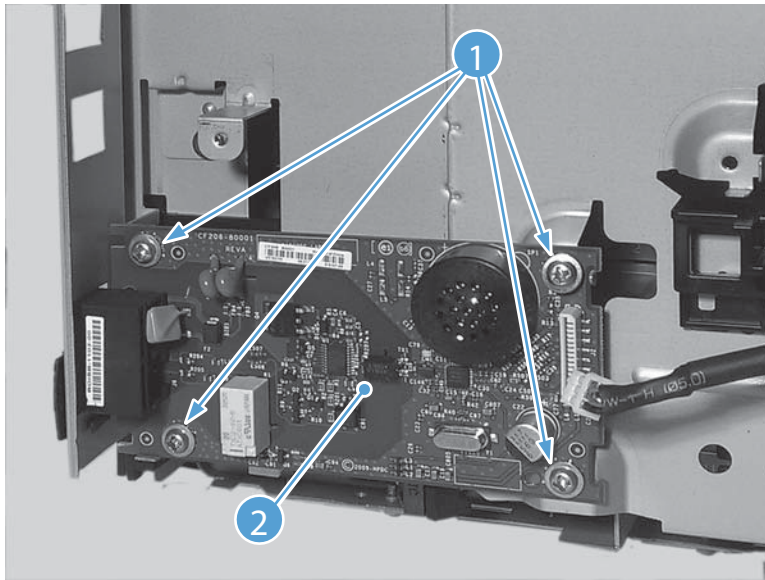

4. Remove five screws (callout 1), and then remove the sheet-metal plate (callout 2).

Figure 1-104 Remove the pickup assembly (4 of 10)

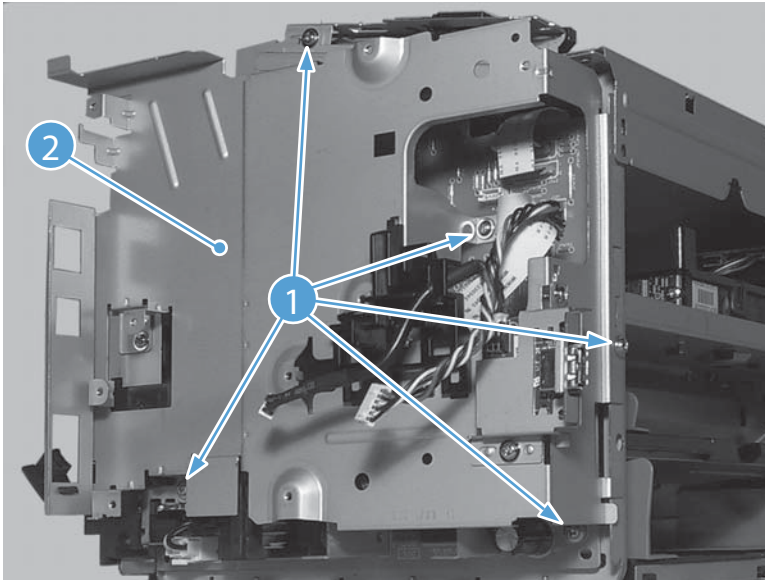

5. Disconnect one connector (callout 1), and then release the wire harness (callout 2) from the guide (callout 3).

Figure 1-105 Remove the pickup assembly (5 of 10)

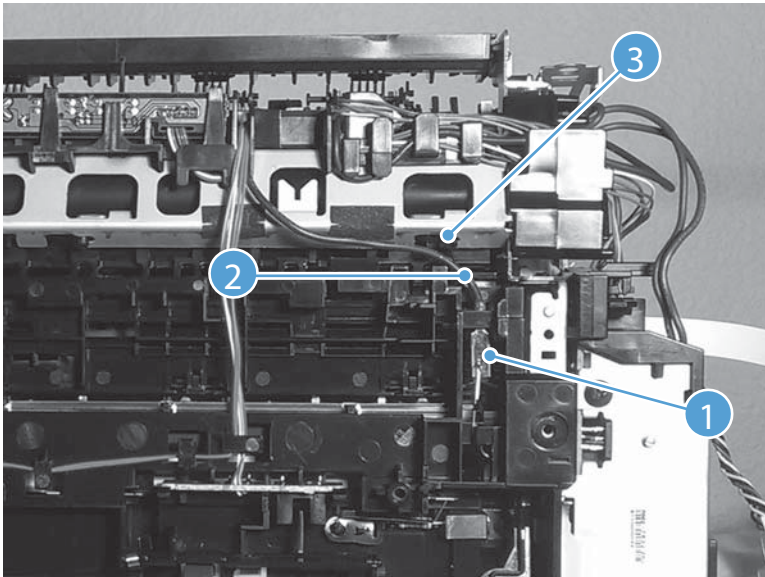

6. Disconnect three connectors (callout 1), and then remove the wire harness (callout 2) from the guide (callout 3).

 **Reinstallation tip:** When the pickup assembly is reinstalled, place these wire harnesses in the guide first, and then the wire harness from the ground connector in the previous step. This ensures that the harnesses are long enough for the connectors to reach the engine controller PCA.

Figure 1-106 Remove the pickup assembly (6 of 10)



7. Remove one bushing (callout 1).

Figure 1-107 Remove the pickup assembly (7 of 10)

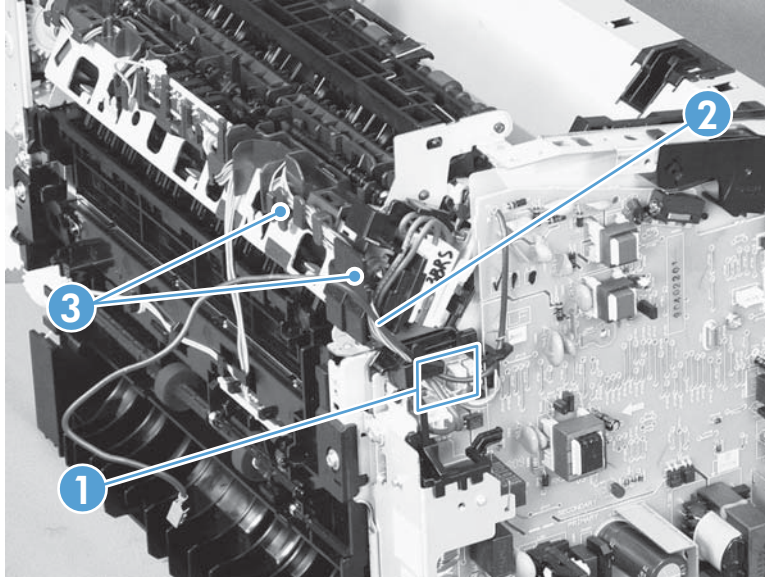
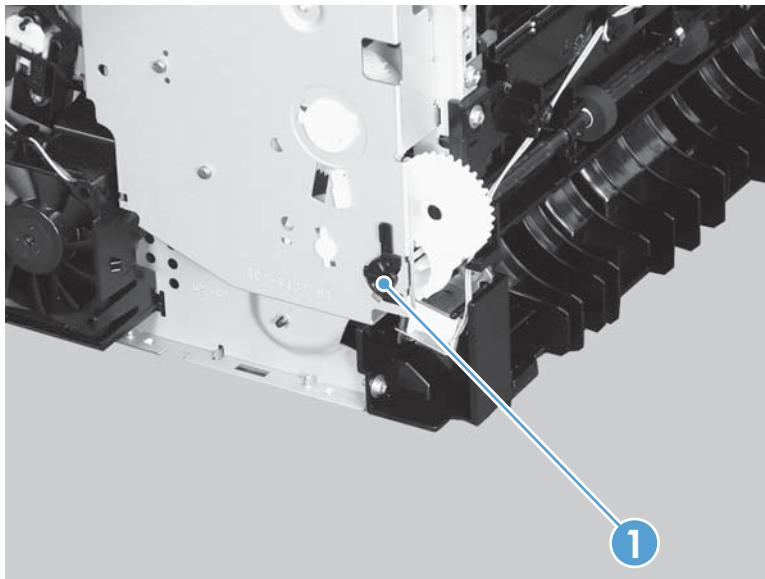

8. Remove one screw with washer (callout 1).

Figure 1-108 Remove the pickup assembly (8 of 10)

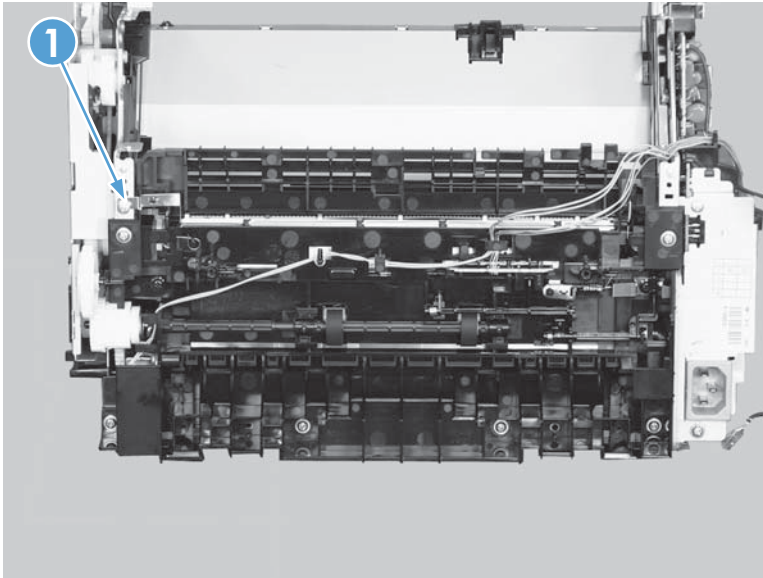

9. Remove six screws (callout 1), and then remove the pickup assembly (callout 2).

CAUTION: The ground spring on the assembly is not captive. Do not lose the spring when the assembly is removed. See [Reinstall the pickup assembly on page 75](#).

Figure 1-109 Remove the pickup assembly (9 of 10)

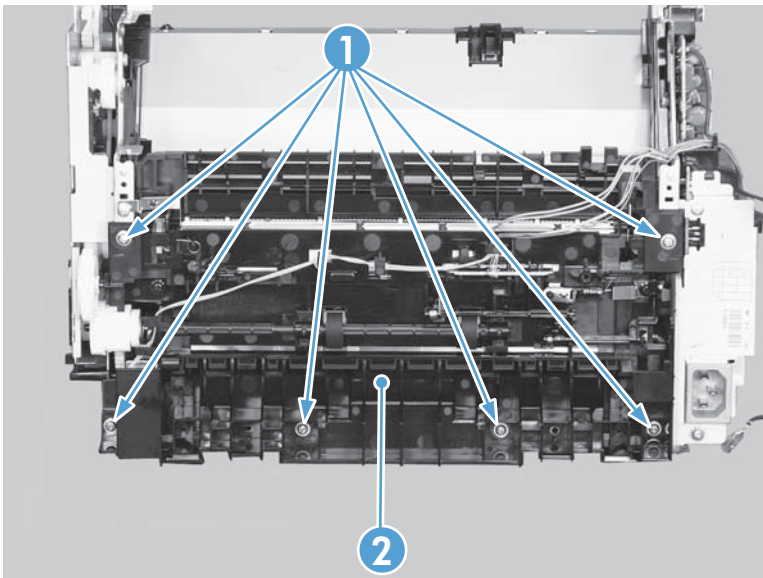

- 10. Duplex models only:** Remove one gear (callout 1) from the pickup assembly (callout 2).

CAUTION: The gear is not captive. Do not lose the gear while servicing the product.

Figure 1-110 Remove the pickup assembly (10 of 10)

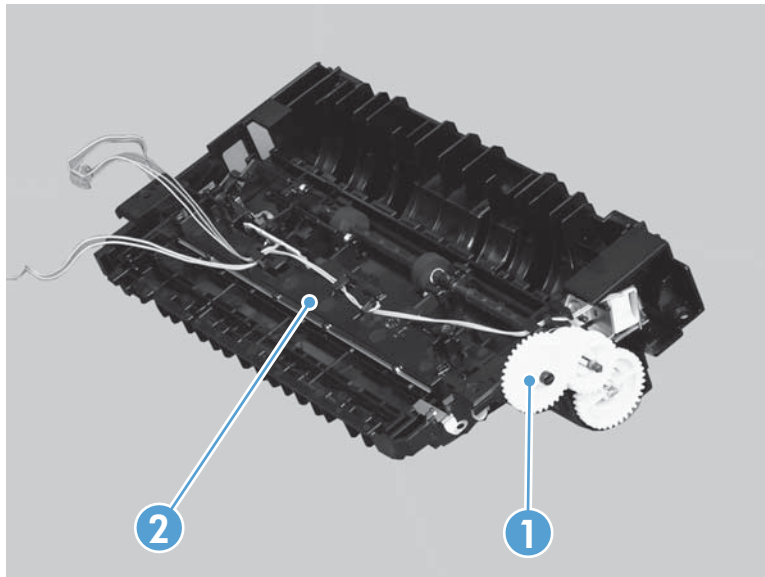

Reinstall the pickup assembly

1. Make sure that the pickup assembly ground spring is correctly positioned when the assembly is reinstalled.

Figure 1-111 Reinstall the pickup assembly (1 of 4; correct ground spring position)

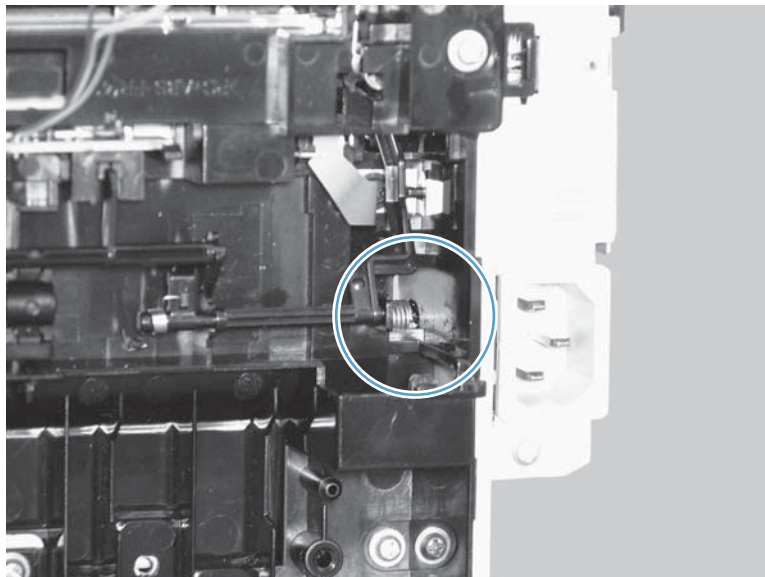
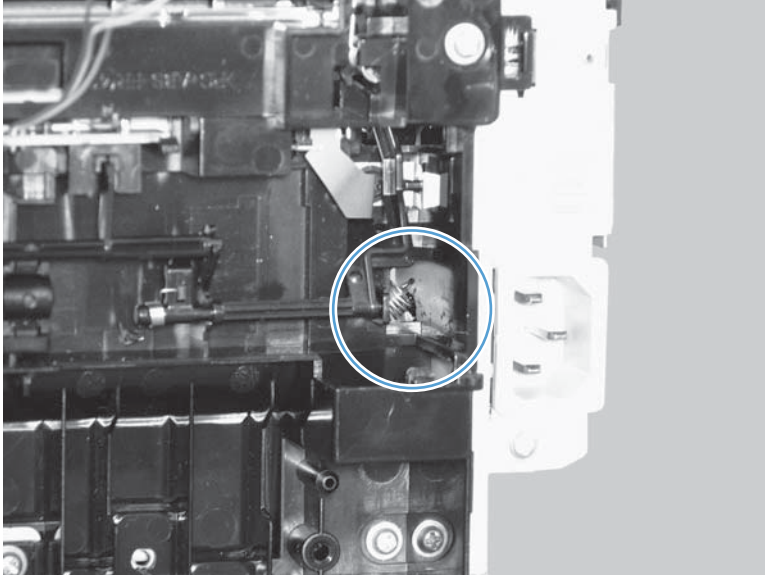

Figure 1-112 Reinstall the pickup assembly (2 of 4; incorrect ground spring position)



2. Push down the lift plate before installing the pickup assembly.

 **TIP:** Reach in from the front of the product to push and hold the plate down as the pickup unit is installed.

Figure 1-113 Reinstall the pickup assembly (3 of 4; lift plate in raised position)

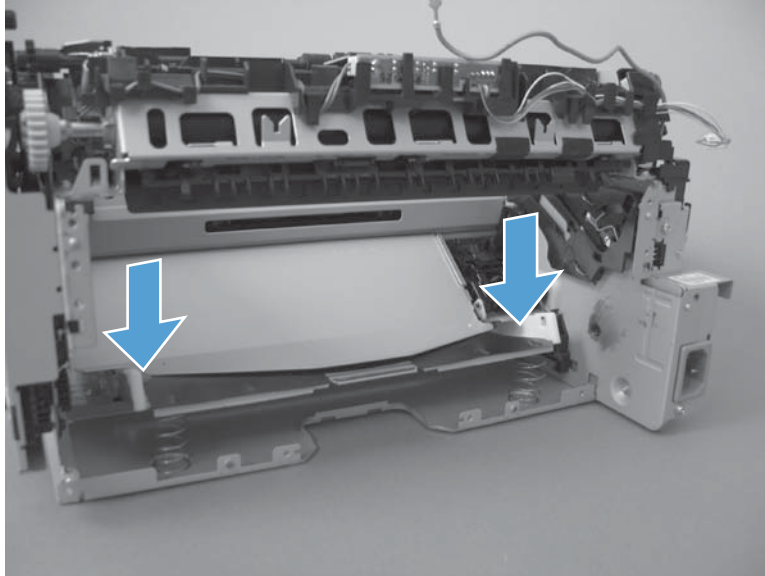
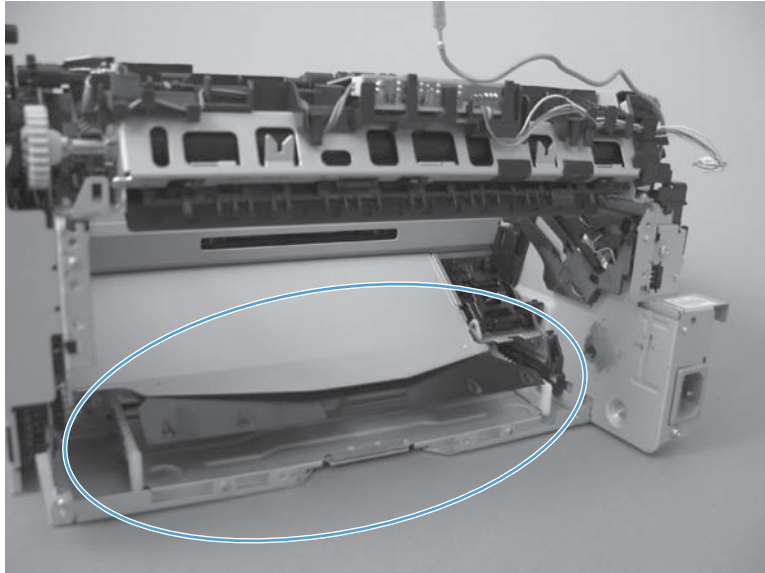

Figure 1-114 Reinstall the pickup assembly (4 of 4; lift plate in lowered position)



Main motor

Before proceeding, remove the following components:

- Dust cover. See [Dust cover on page 11](#) or [Dust cover on page 36](#)
- Input tray assembly. See [Input tray assembly on page 11](#) or [Input tray assembly on page 36](#).
- Output tray assembly. See [Output tray assembly on page 11](#) or [Output tray assembly on page 37](#).
- Left cover. See [Left cover, duplex product on page 12](#) or [Left cover, simplex product on page 13](#) or [Left cover on page 37](#).
- Front cover assembly. See [Front cover assembly on page 15](#) or [Front cover assembly on page 38](#).
- Right cover. See [Right cover, duplex product on page 16](#) or [Right cover, simplex product on page 18](#) or [Right cover on page 40](#).

Remove the main motor

1. Release one tab (callout 1), and then remove the holder (callout 2).

Figure 1-115 Remove the main motor (1 of 9)

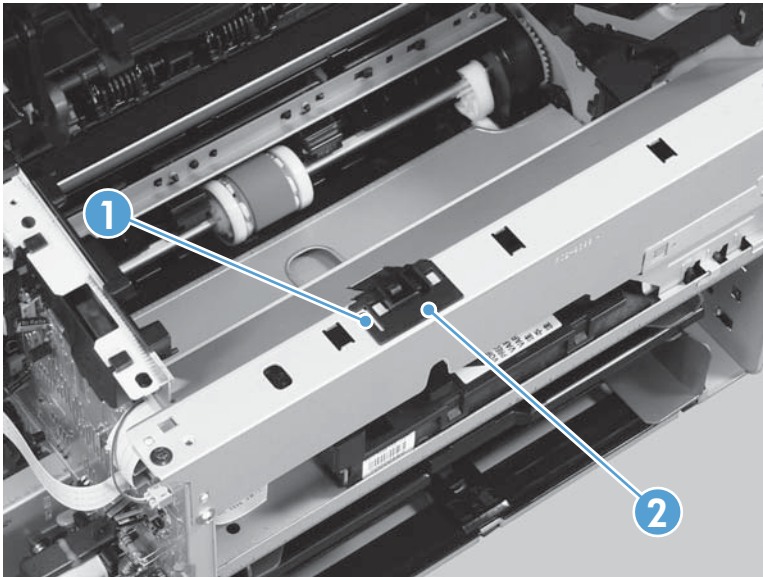

2. Remove four screws (callout 1), the scanner cover (callout 2) and the sheet-metal plate (callout 3).

 **NOTE:** The scanner cover and plate are removed as one assembly.

 **TIP:** When the cover is reinstalled, make sure that the black screws (callout 4) are installed in the correct screw holes.

Figure 1-116 Remove the main motor (2 of 9)



3. **Simplex models only:** Disconnect one connector (callout 1).

Duplex models only: Disconnect three connectors (callout 1 and callout 2).

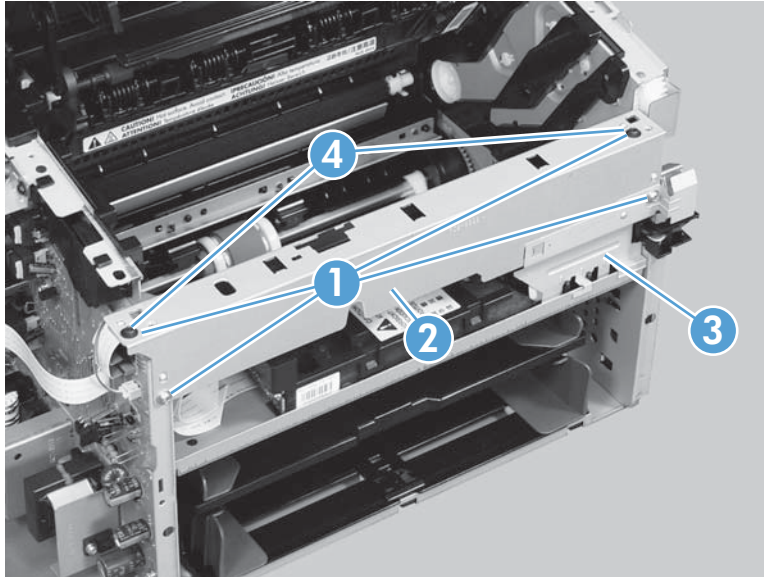
 **NOTE:** Simplex models do not have the duplex-connector PCA installed.

Figure 1-117 Remove the main motor (3 of 9)



4. Release two tabs (callout 1), and then slightly separate the motor driver PCA (callout 2) from the product.

⚠ CAUTION: The motor driver PCA is still connected to the product by the wire harnesses and a FFC.

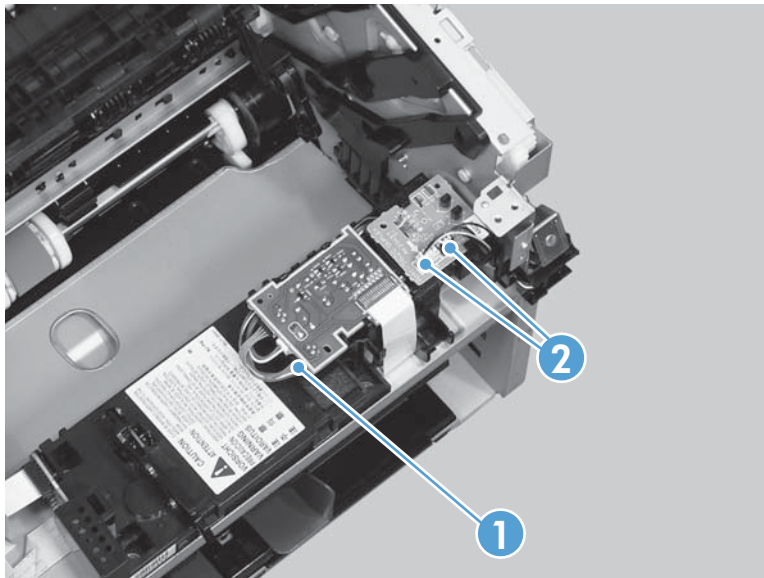
Figure 1-118 Remove the main motor (4 of 9)

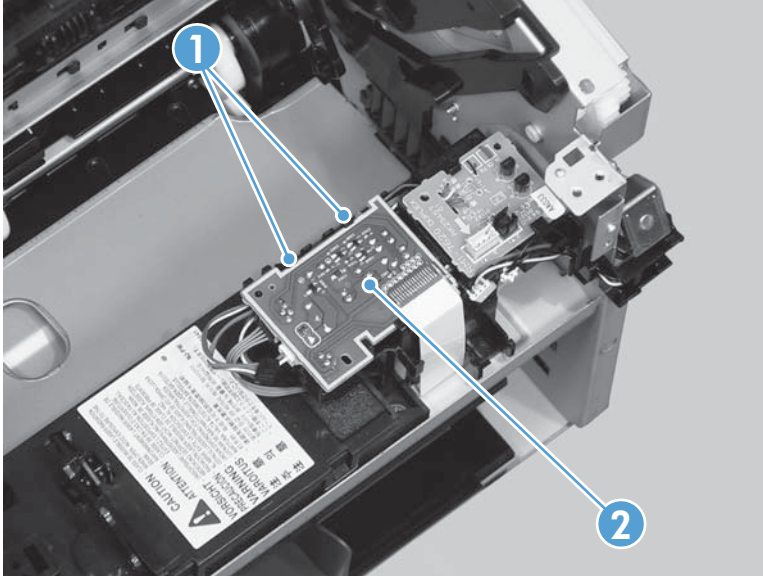

5. **Duplex models only:** Release one tab (callout 1), and then remove the duplex-connector PCA (callout 2).

Figure 1-119 Remove the main motor (5 of 9)

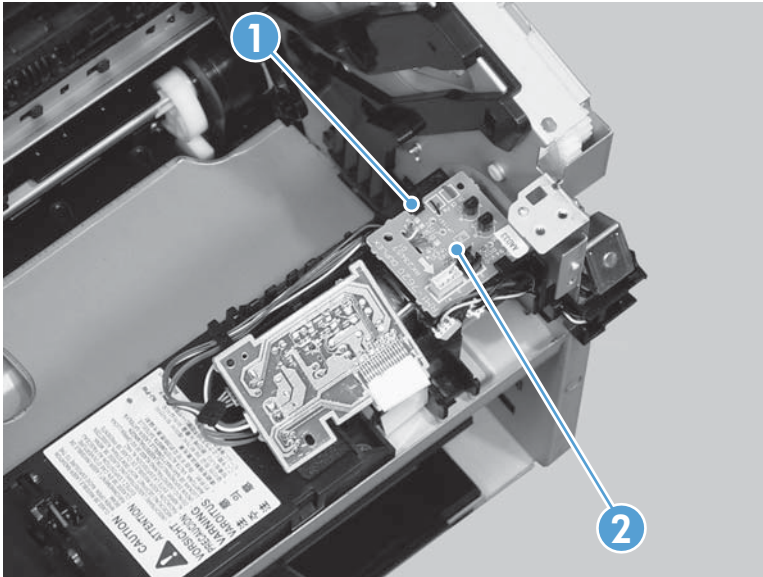

6. Disconnect two connectors (callout 1) and carefully set the PCA out of the way.

⚠ CAUTION: The motor driver PCA is still connected to the product by the FFC.

Figure 1-120 Remove the main motor (6 of 9)

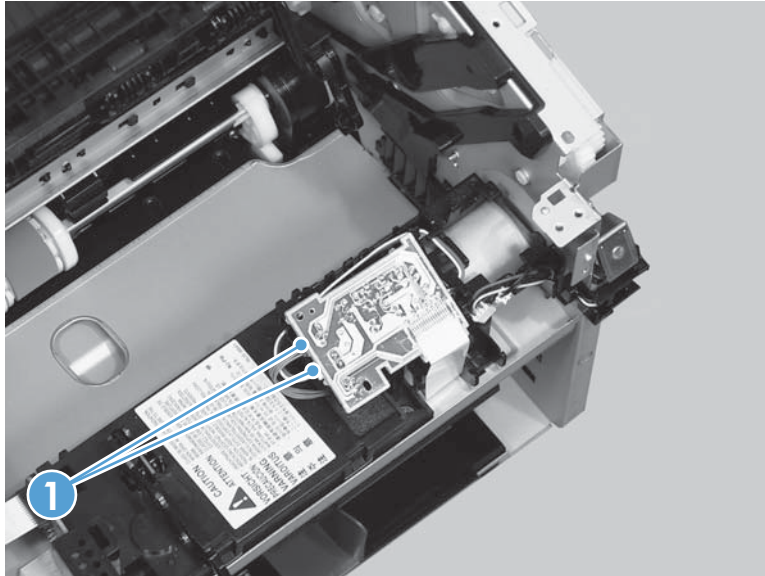

7. Release the wire harness (callout 1) from the guide (callout 2).

Figure 1-121 Remove the main motor (7 of 9)

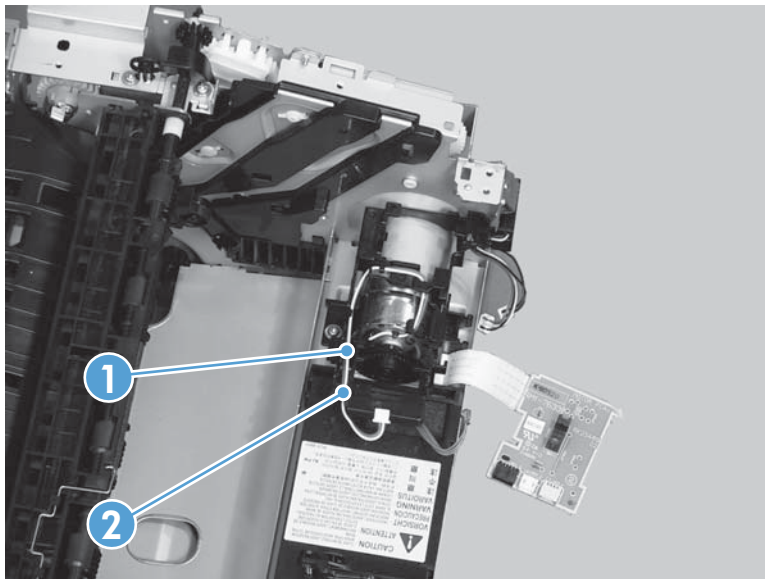

8. Remove one screw (callout 1), and then remove the motor cover (callout 2).

Figure 1-122 Remove the main motor (8 of 9)

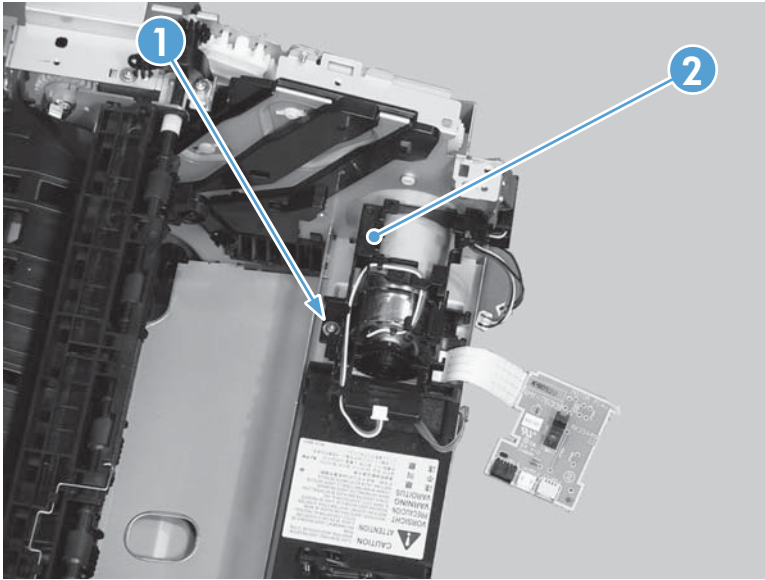

9. Remove two screws (callout 1), and then remove the motor (callout 2).

Figure 1-123 Remove the main motor (9 of 9)

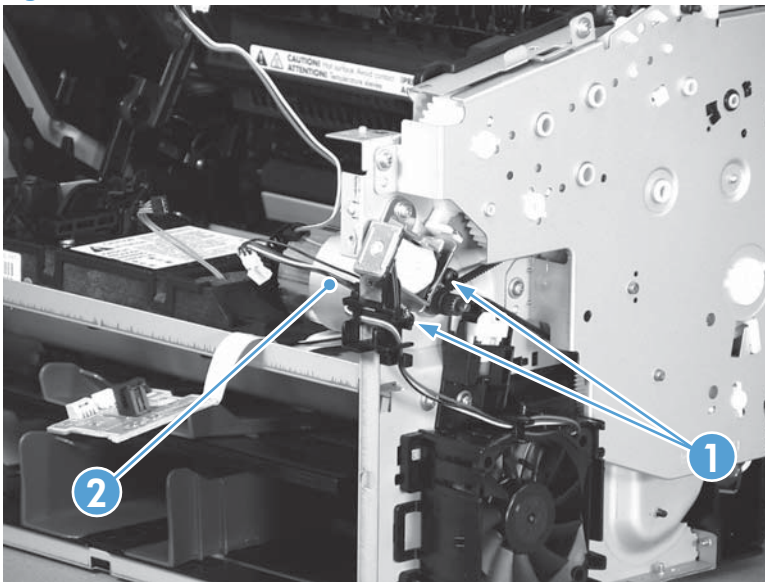

Reinstall the main-motor drive belt

- ▲ When the main motor is reinstalled, make sure that the drive belt (callout 1) is correctly positioned over the roller (callout 2).

Figure 1-124 Main-motor drive belt: correctly installed

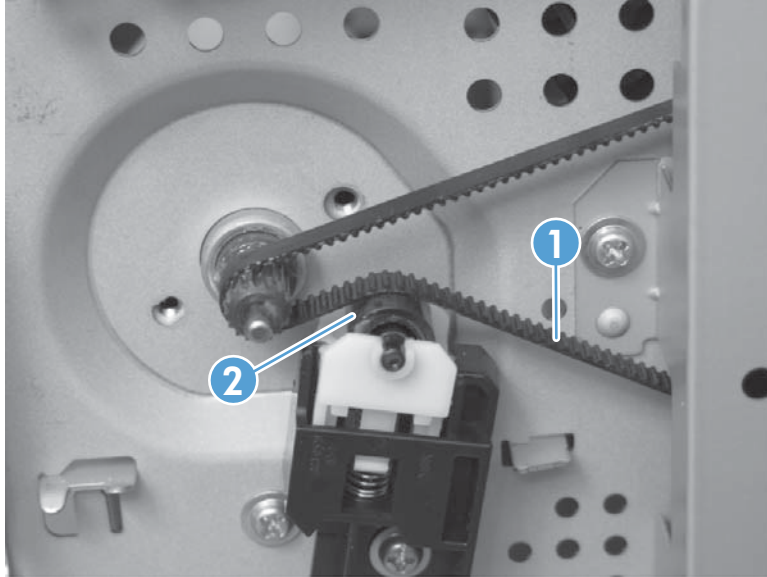
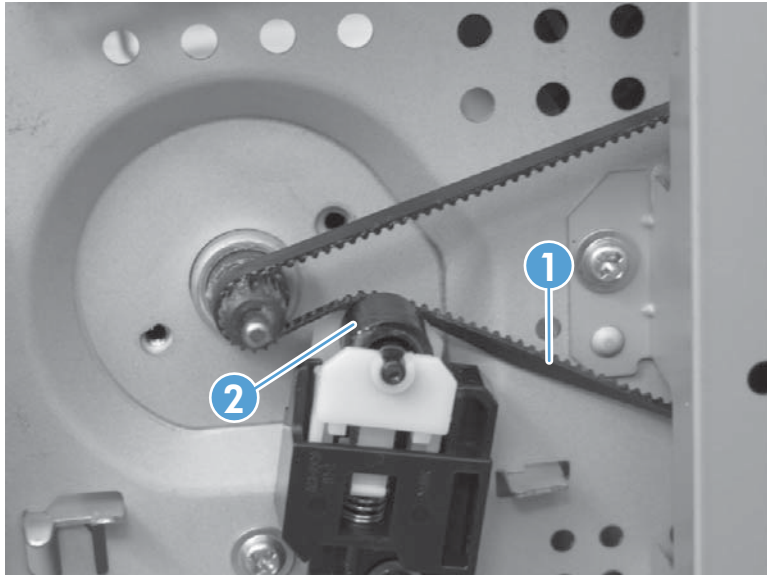

Figure 1-125 Main-motor drive belt: incorrectly installed



Pickup solenoid

Before proceeding, remove the following components:

- Dust cover. See [Dust cover on page 11](#) or [Dust cover on page 36](#)
- Input tray assembly. See [Input tray assembly on page 11](#) or [Input tray assembly on page 36](#).
- Output tray assembly. See [Output tray assembly on page 11](#) or [Output tray assembly on page 37](#).
- Left cover. See [Left cover, duplex product on page 12](#) or [Left cover, simplex product on page 13](#) or [Left cover on page 37](#).
- Front cover assembly. See [Front cover assembly on page 15](#) or [Front cover assembly on page 38](#).
- Right cover. See [Right cover, duplex product on page 16](#) or [Right cover, simplex product on page 18](#) or [Right cover on page 40](#).
- Rear cover (simplex product) or duplex door (duplex product). See [Rear cover, simplex product on page 22](#) or [Duplex door, duplex product on page 20](#) or [Duplex door on page 46](#).
- Duplex frame (duplex products only). See [Duplex frame, duplex product on page 21](#) or [Duplex frame on page 47](#).
- Cartridge door. See [Cartridge door, duplex product on page 29](#) or [Cartridge door, simplex product on page 23](#) or [Cartridge door on page 48](#).
- Top cover. See [Top cover on page 33](#) or [Top cover on page 52](#).
- Formatter PCA. See [Formatter PCA on page 54](#)

Remove the pickup solenoid

1. **Duplex models only:** Release two tabs (callout 1), and then remove the duplex reverse guide (callout 2).

Figure 1-126 Remove the pickup solenoid (1 of 7)

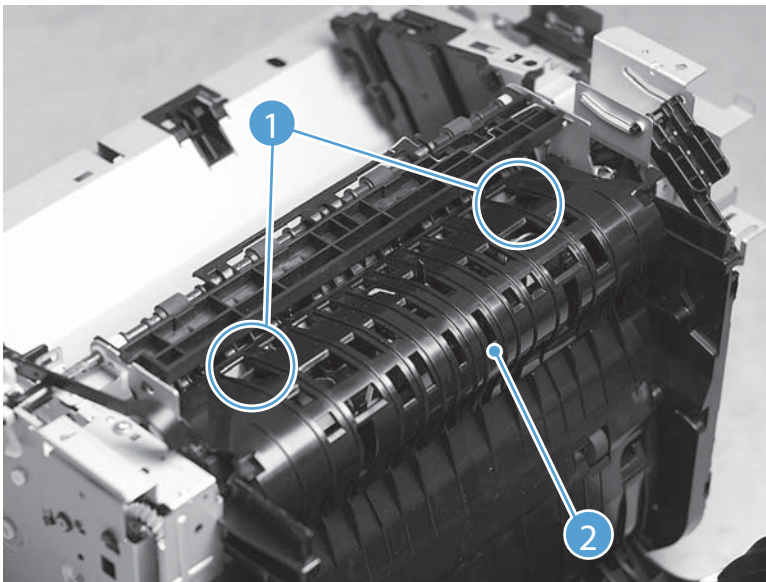

2. Remove two screws (callout 1), and then remove the sheet-metal corner brace (callout 2).

Figure 1-127 Remove the pickup solenoid (2 of 7)

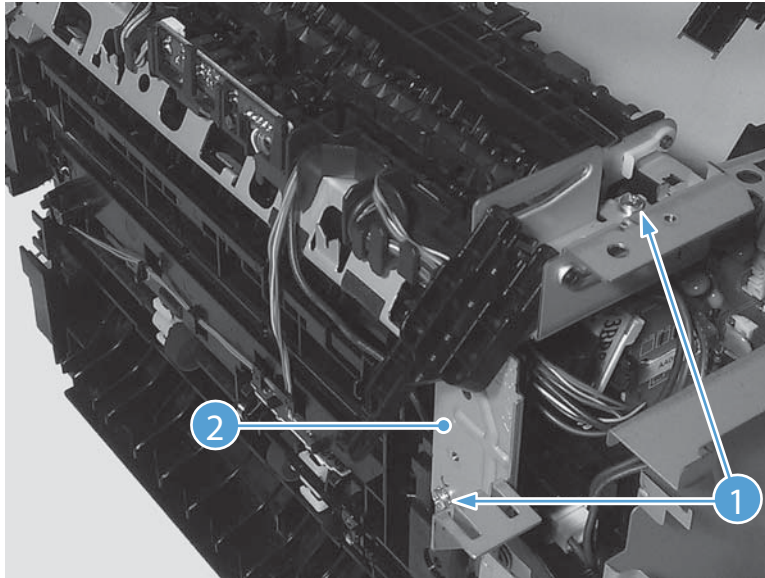

3. Remove four screws (callout 1), and then remove the fax PCA (callout 2).

Figure 1-128 Remove the pickup solenoid (3 of 7)

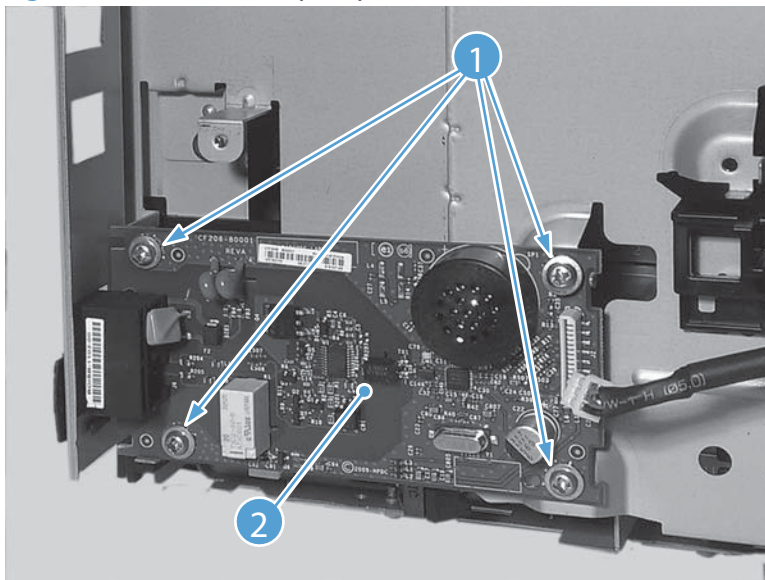

4. Remove five screws (callout 1), and then remove the sheet-metal plate (callout 2).

Figure 1-129 Remove the pickup solenoid (4 of 7)

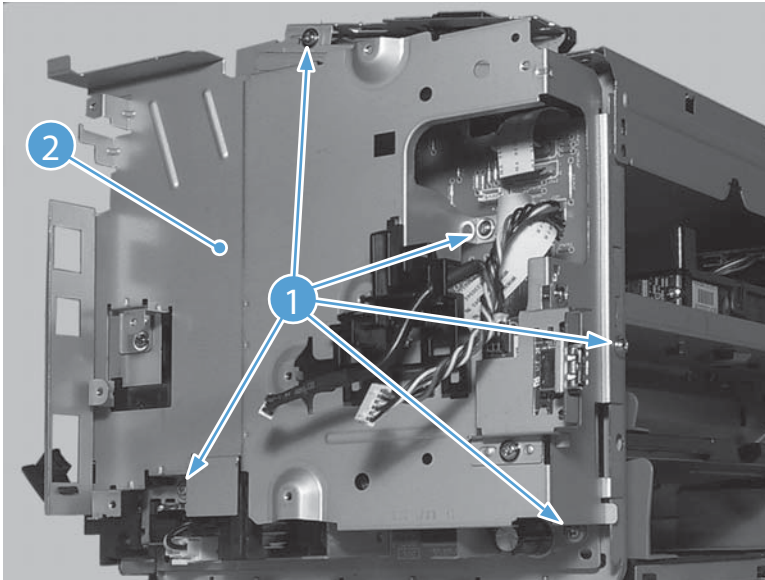

5. Disconnect one connector (callout 1), and then remove the wire harness (callout 2) from the guide (callout 3).

Figure 1-130 Remove the solenoid (5 of 7)

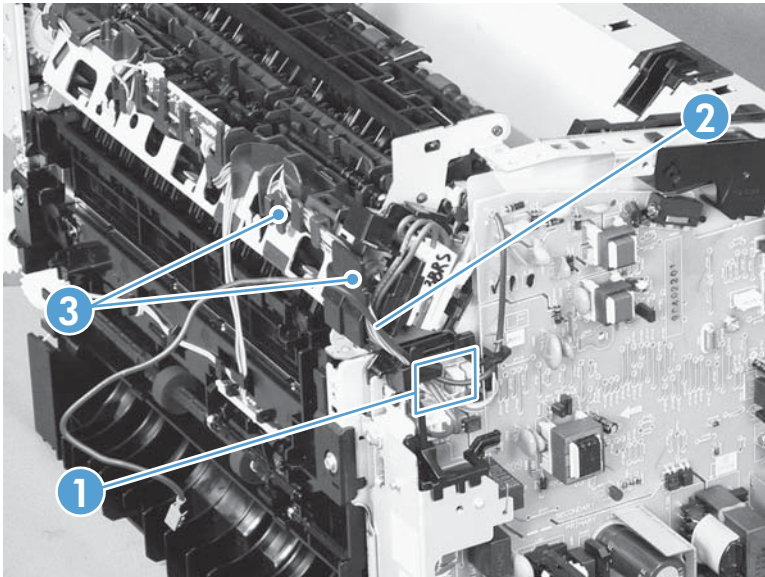

6. Release the wire harness (callout 1) from the guide (callout 2).

Figure 1-131 Remove the pickup solenoid (6 of 7)

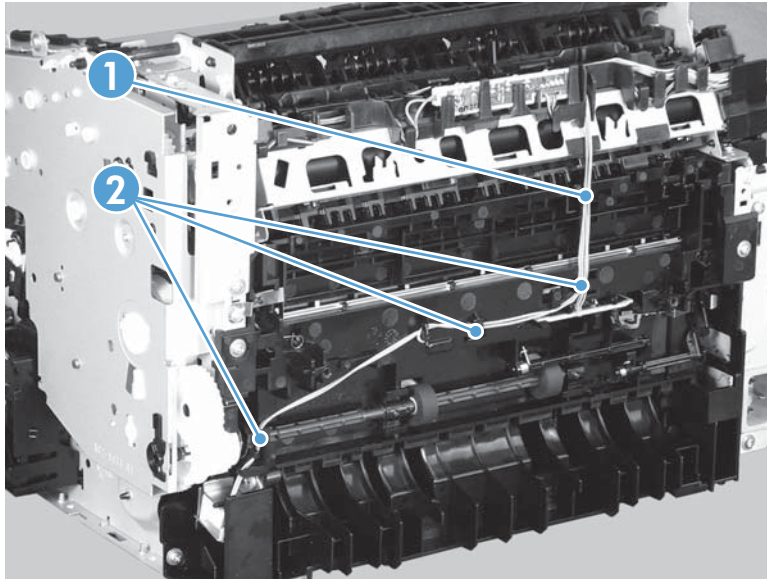

7. Remove one screw (callout 1), and then remove the pickup solenoid (callout 2).

Figure 1-132 Remove the pickup solenoid (7 of 7)

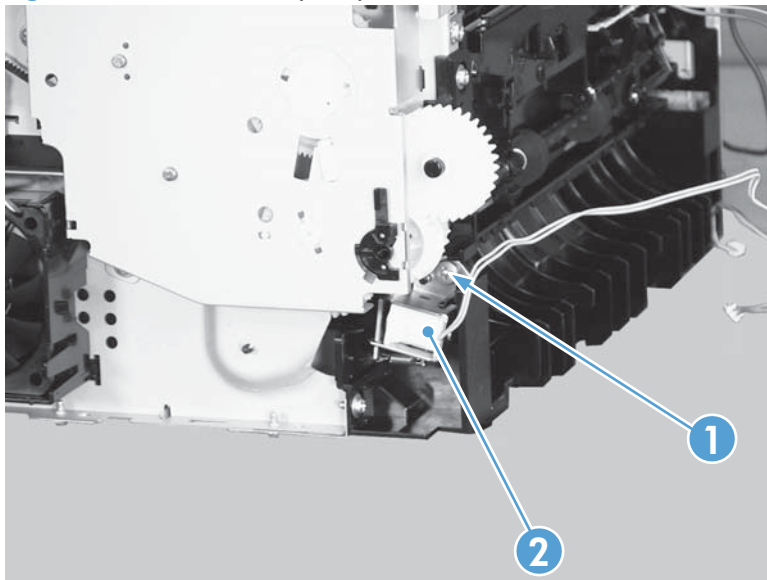

Engine controller PCA

Before proceeding, remove the following components:

- Dust cover. See [Dust cover on page 11](#) or [Dust cover on page 36](#)
- Input tray assembly. See [Input tray assembly on page 11](#) or [Input tray assembly on page 36](#).
- Output tray assembly. See [Output tray assembly on page 11](#) or [Output tray assembly on page 37](#).
- Left cover. See [Left cover, duplex product on page 12](#) or [Left cover, simplex product on page 13](#) or [Left cover on page 37](#).
- Front cover assembly. See [Front cover assembly on page 15](#) or [Front cover assembly on page 38](#).
- Right cover. See [Right cover, duplex product on page 16](#) or [Right cover, simplex product on page 18](#) or [Right cover on page 40](#).
- Rear cover (simplex product) or duplex door (duplex product). See [Rear cover, simplex product on page 22](#) or [Duplex door, duplex product on page 20](#) or [Duplex door on page 46](#).
- Duplex frame (duplex products only). See [Duplex frame, duplex product on page 21](#) or [Duplex frame on page 47](#).
- Cartridge door. See [Cartridge door, duplex product on page 29](#) or [Cartridge door, simplex product on page 23](#) or [Cartridge door on page 48](#).
- Top cover. See [Top cover on page 33](#) or [Top cover on page 52](#).
- Formatter PCA. See [Formatter PCA on page 54](#)

Remove the engine controller PCA

1. **Duplex models only:** Release two tabs (callout 1), and then remove the duplex reverse guide (callout 2).

Figure 1-133 Remove the engine controller PCA (1 of 10)

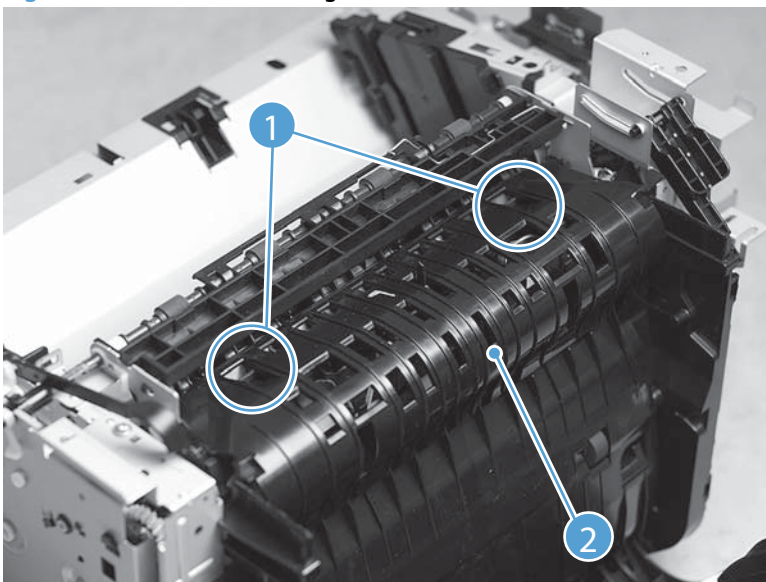

2. Remove two screws (callout 1), and then remove the sheet-metal corner brace (callout 2).

Figure 1-134 Remove the engine controller PCA (2 of 10)

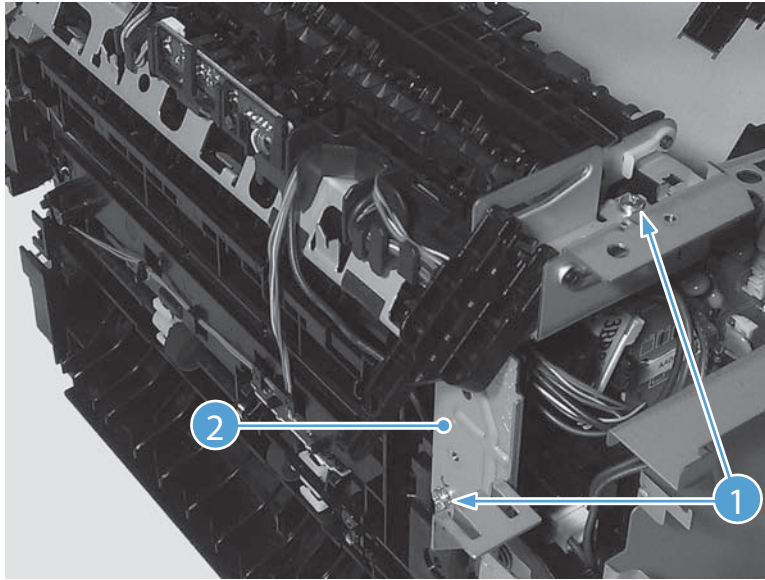

3. Remove four screws (callout 1), and then remove the fax PCA (callout 2).

Figure 1-135 Remove the engine controller PCA (3 of 10)

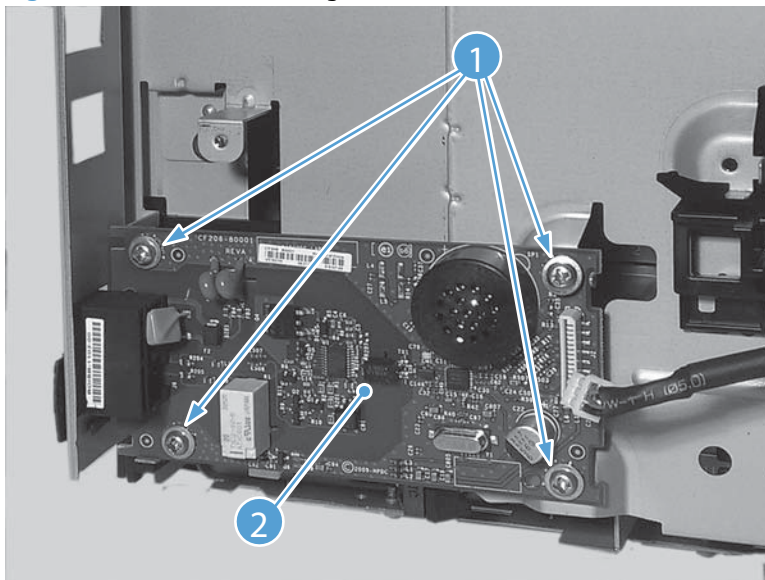

4. Remove five screws (callout 1), and then remove the sheet-metal plate (callout 2).

Figure 1-136 Remove the engine controller PCA (4 of 10)

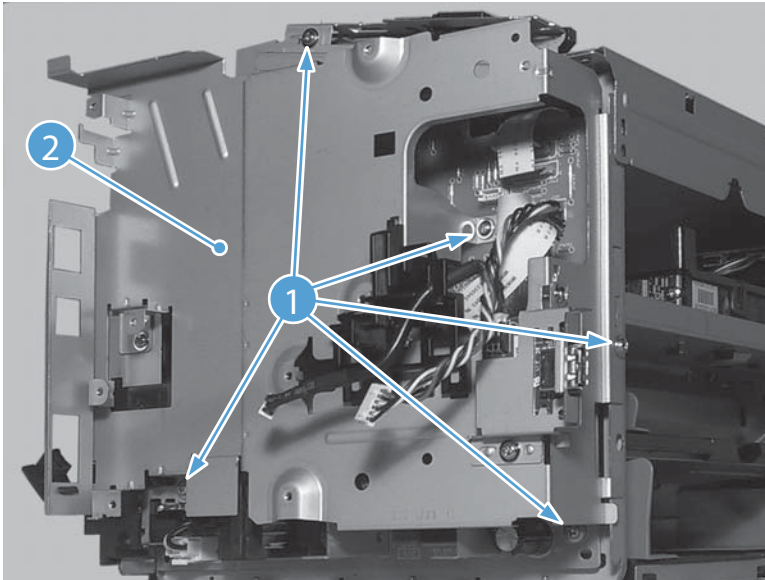

5. Disconnect one connector (callout 1), and then release the wire harness (callout 2) from the guides (callout 3).

Figure 1-137 Remove the engine controller PCA (5 of 10)

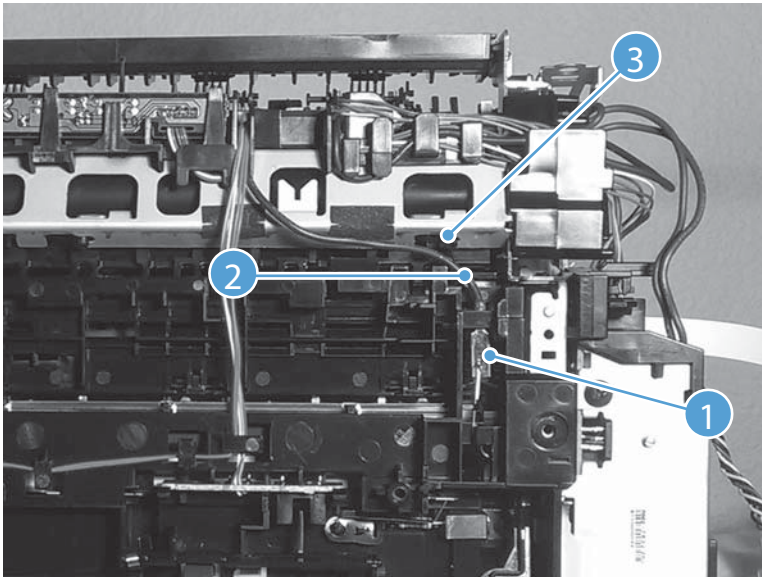

6. Disconnect four connectors (callout 1), and then remove the wire harnesses (callout 2) from the guide (callout 3).

Figure 1-138 Remove the engine controller PCA (6 of 10)

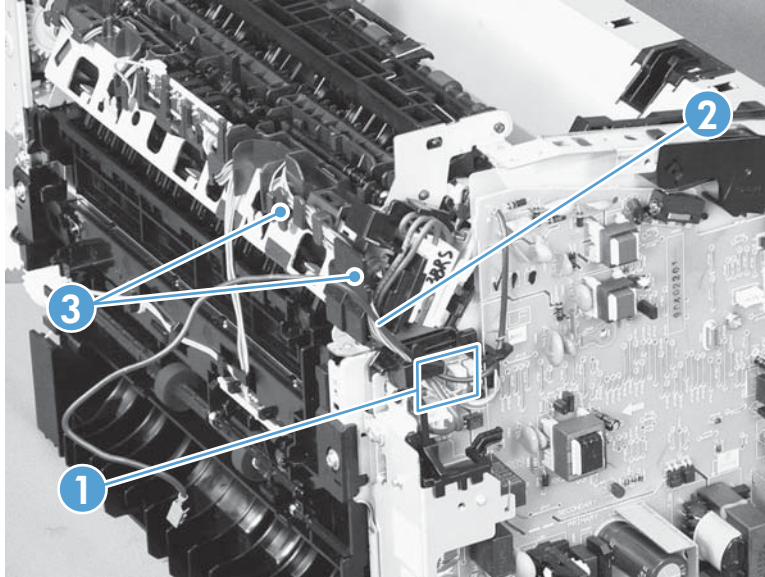

7. Release the wire harness (callout 1) from the ground spring (callout 2).

Figure 1-139 Remove the engine controller PCA (7 of 10)

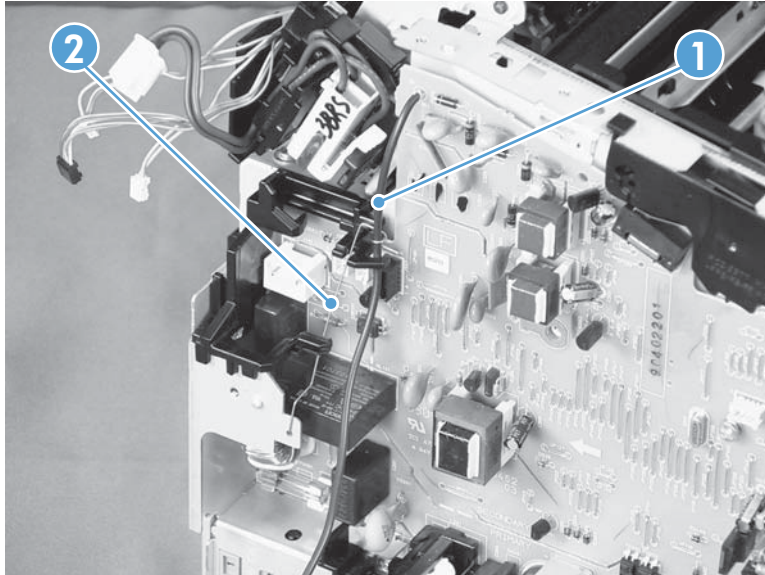

8. Disconnect two connectors (callout 1) and two FFCs (callout 2).

Figure 1-140 Remove the engine controller PCA (8 of 10)

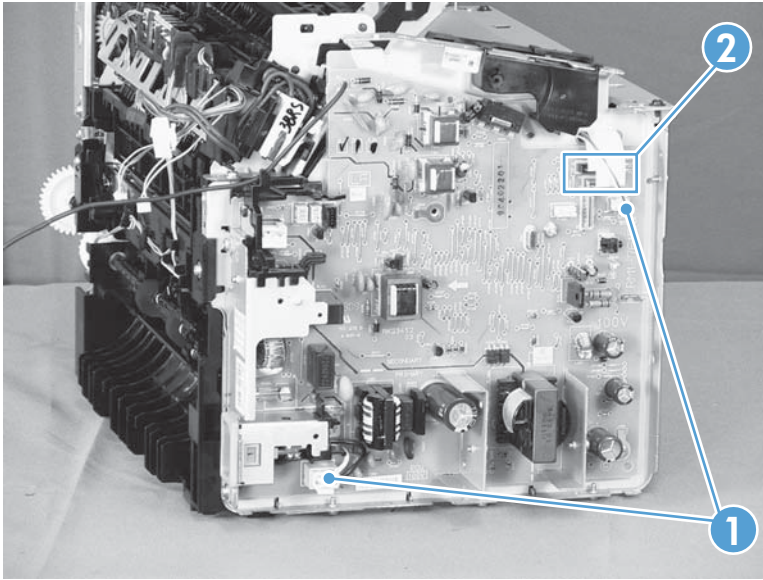

9. Remove one screw with washer (callout 1), and then remove one more screw (callout 2).

Figure 1-141 Remove the engine controller PCA (9 of 10)

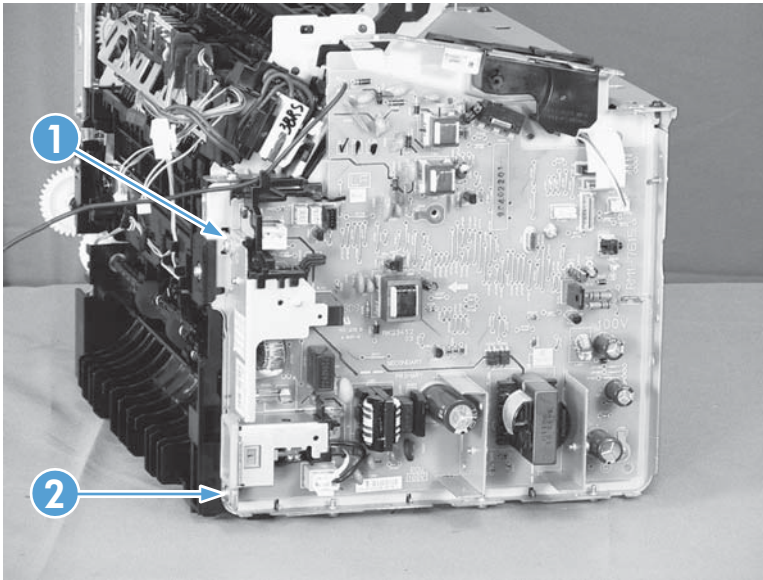

10. Remove three screws with washers (callout 1), and then remove the engine controller PCA (callout 2).

Figure 1-142 Remove the engine controller PCA (10 of 10)

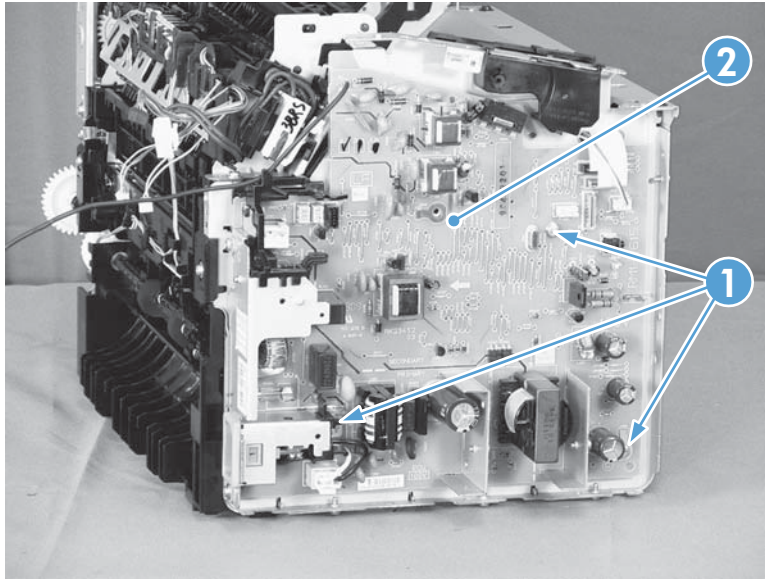

Reinstall the engine controller PCA

 **NOTE:** In addition to following the reverse order of removal, make sure that you complete these steps to correctly install the transfer-wire harness.

1. Set the ground spring (callout 1) on the transfer-wire harness (callout 2).

Figure 1-143 Reinstall the engine controller PCA (1 of 4)

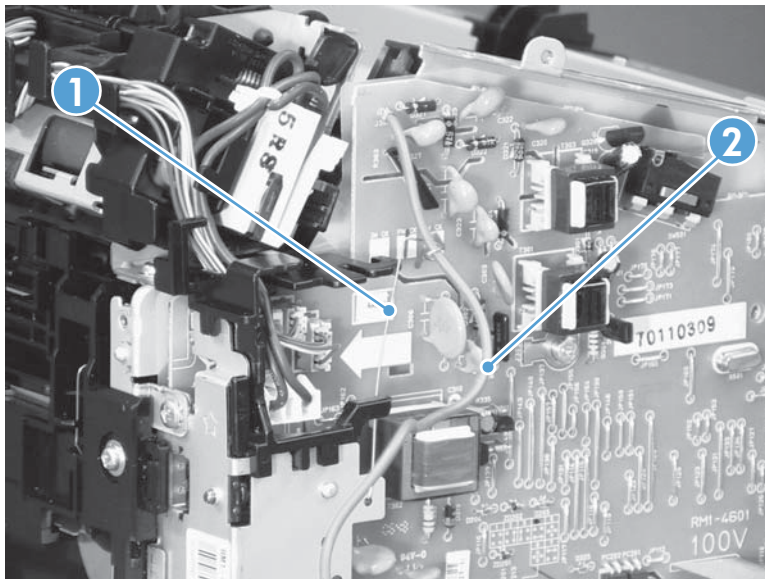

2. Position the transfer-wire harness (callout 1) in the guide (callout 2).

Figure 1-144 Reinstall the engine controller PCA (2 of 4)

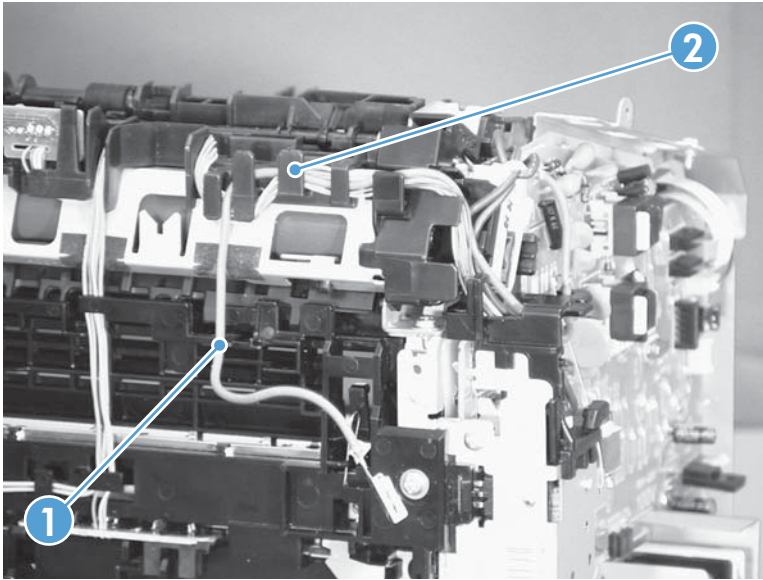

3. Connect one connector (callout 1).

Figure 1-145 Reinstall the engine controller PCA (3 of 4)

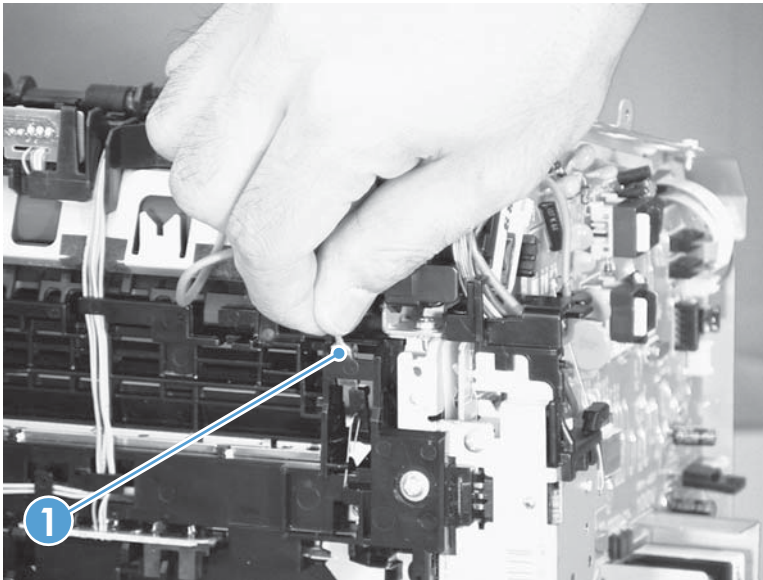

4. Position the transfer-wire harness (callout 1) in the guides (callout 2).

Figure 1-146 Reinstall the engine controller PCA (4 of 4)

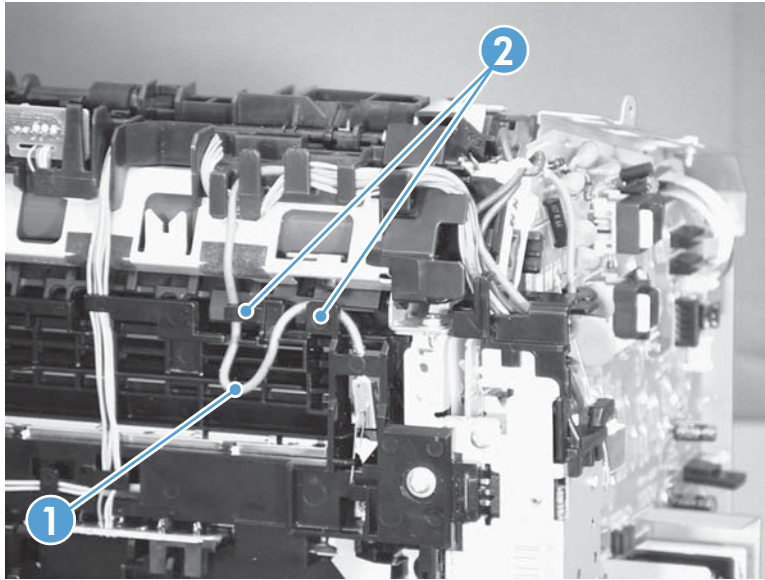

Duplex-reverse solenoid, duplex product

Before proceeding, remove the following components:

- Dust cover. See [Dust cover on page 11](#) or [Dust cover on page 36](#)
- Input tray assembly. See [Input tray assembly on page 11](#) or [Input tray assembly on page 36](#).
- Output tray assembly. See [Output tray assembly on page 11](#) or [Output tray assembly on page 37](#).
- Left cover. See [Left cover, duplex product on page 12](#) or [Left cover on page 37](#).
- Front cover assembly. See [Front cover assembly on page 15](#) or [Front cover assembly on page 38](#).
- Right cover. See [Right cover, duplex product on page 16](#) or [Right cover on page 40](#).

Remove the duplex-reverse solenoid

1. Release one tab (callout 1), and then remove the holder (callout 2).

Figure 1-147 Remove the duplex-reverse solenoid (1 of 5)

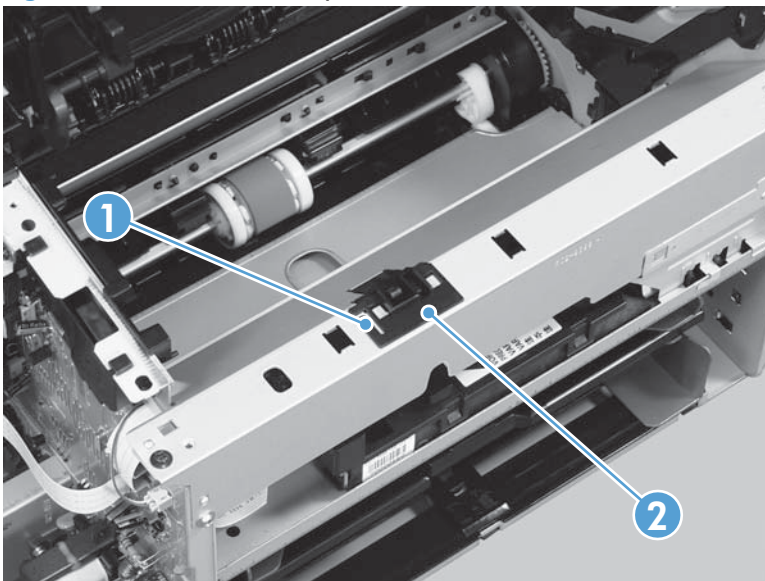

2. Remove four screws (callout 1), the scanner cover (callout 2) and the sheet-metal plate (callout 3).

 **NOTE:** The scanner cover and plate are removed as one assembly.

 **TIP:** When the cover is reinstalled, make sure that the black screws (callout 4) are installed in the correct screw holes.

Figure 1-148 Remove the duplex-reverse solenoid (2 of 5)



3. Disconnect two connectors (callout 1), and then release the wire harness (callout 2) from the guides (callout 3).

Figure 1-149 Remove the duplex-reverse solenoid (3 of 5)

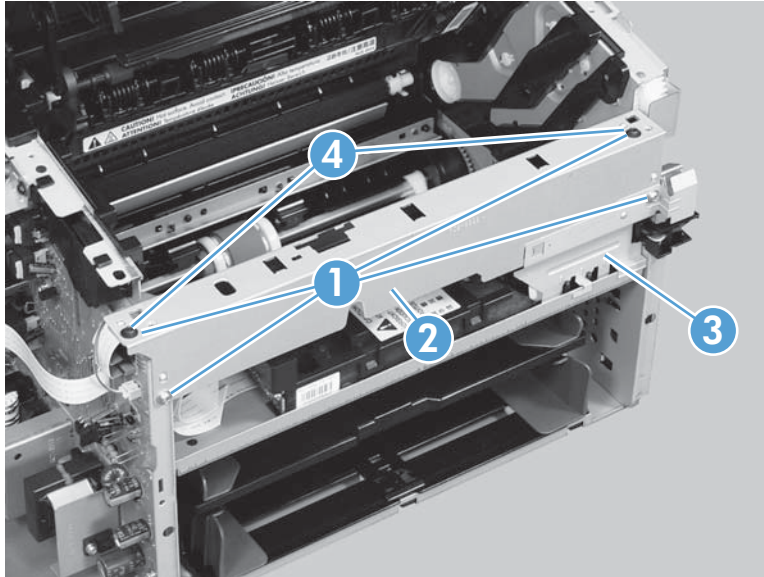
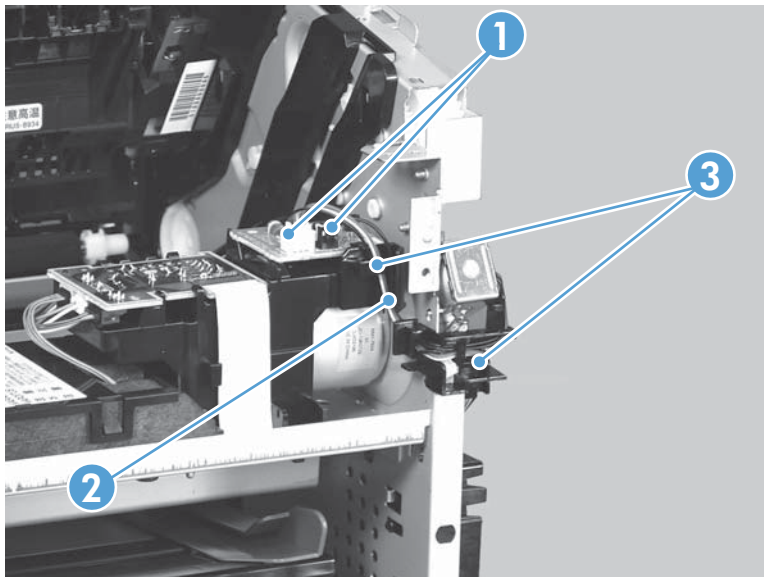

4. Release one tab (callout 1), and then remove the guides (callout 2).

Figure 1-150 Remove the duplex-reverse solenoid (4 of 5)

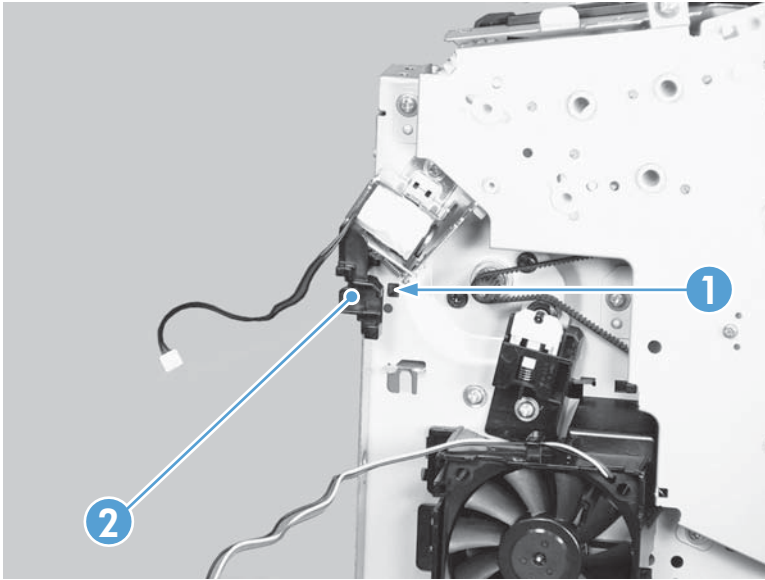

5. Remove one screw (callout 1), and then remove the duplex-reverse solenoid (callout 2).

Figure 1-151 Remove the duplex-reverse solenoid (5 of 5)

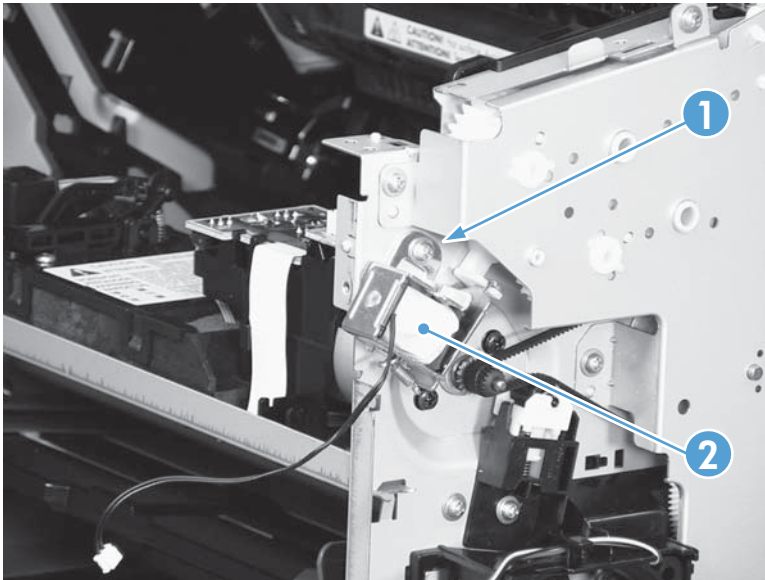

Main fan, duplex product

Before proceeding, remove the following components:

- Dust cover. See [Dust cover on page 11](#) or [Dust cover on page 36](#)
- Input tray assembly. See [Input tray assembly on page 11](#) or [Input tray assembly on page 36](#).
- Output tray assembly. See [Output tray assembly on page 11](#) or [Output tray assembly on page 37](#).
- Left cover. See [Left cover, duplex product on page 12](#) or [Left cover, simplex product on page 13](#) or [Left cover on page 37](#).
- Front cover assembly. See [Front cover assembly on page 15](#) or [Front cover assembly on page 38](#).
- Right cover. See [Right cover, duplex product on page 16](#) or [Right cover, simplex product on page 18](#) or [Right cover on page 40](#).

Remove the main fan

1. Release one tab (callout 1), and then remove the holder (callout 2).

Figure 1-152 Remove the main fan (1 of 4)

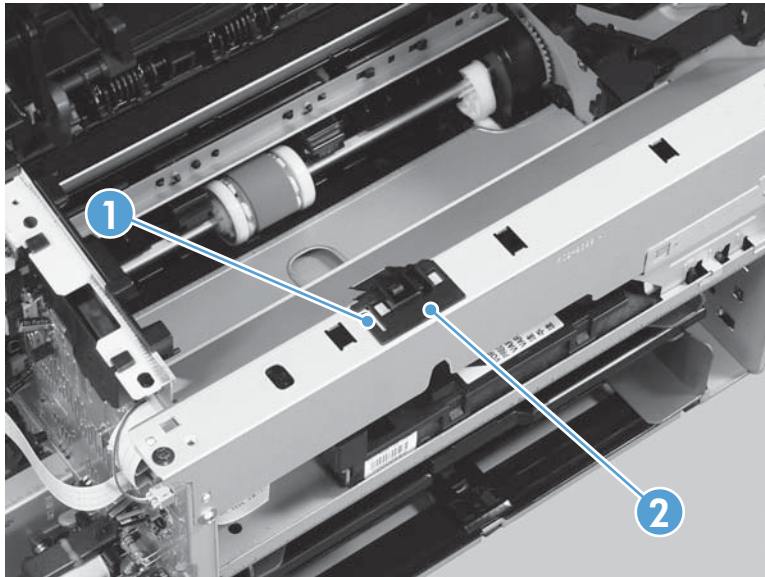

2. Remove four screws (callout 1), the scanner cover (callout 2) and the sheet-metal plate (callout 3).

 **NOTE:** The scanner cover and plate are removed as one assembly.

 **TIP:** When the cover is reinstalled, make sure that the black screws (callout 4) are installed in the correct screw holes.

Figure 1-153 Remove the main fan (2 of 4)



3. Disconnect one connector (callout 1), and then release the wire harness (callout 2) from the guides (callout 3).

Figure 1-154 Remove the main fan (3 of 4)

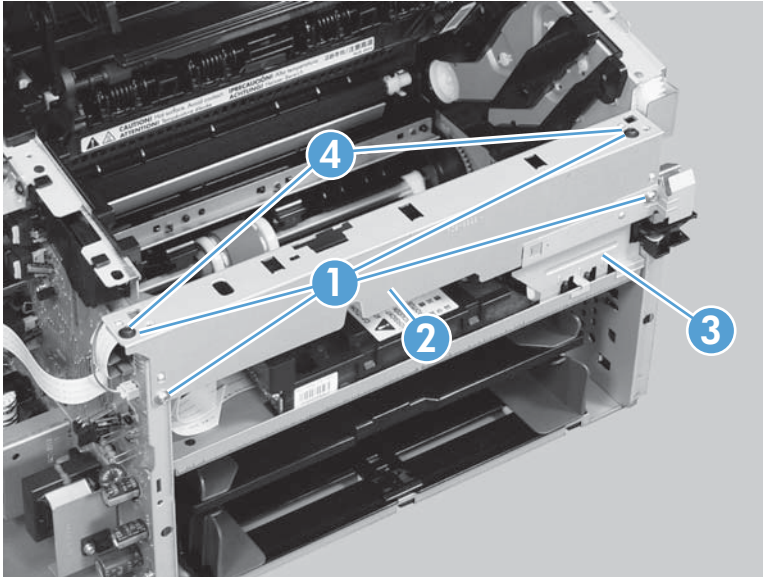
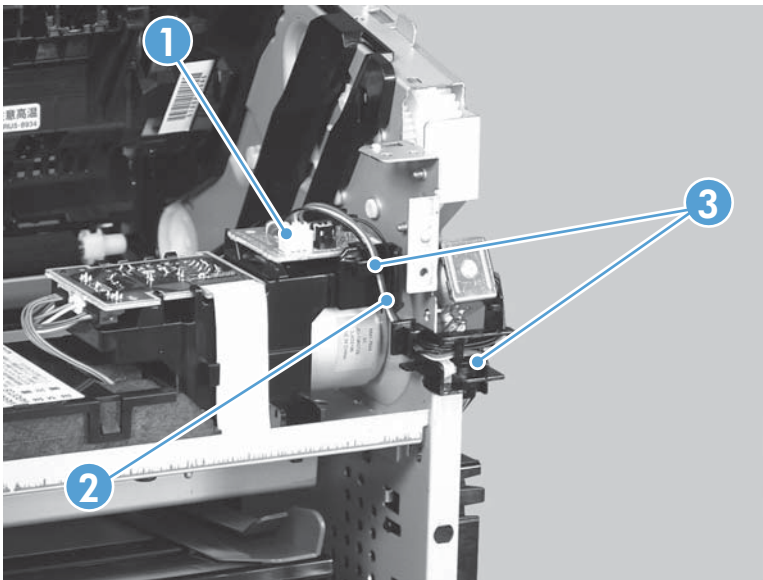

4. Release two tabs (callout 1), and then remove the main fan (callout 2).

Figure 1-155 Remove the main fan (4 of 4)

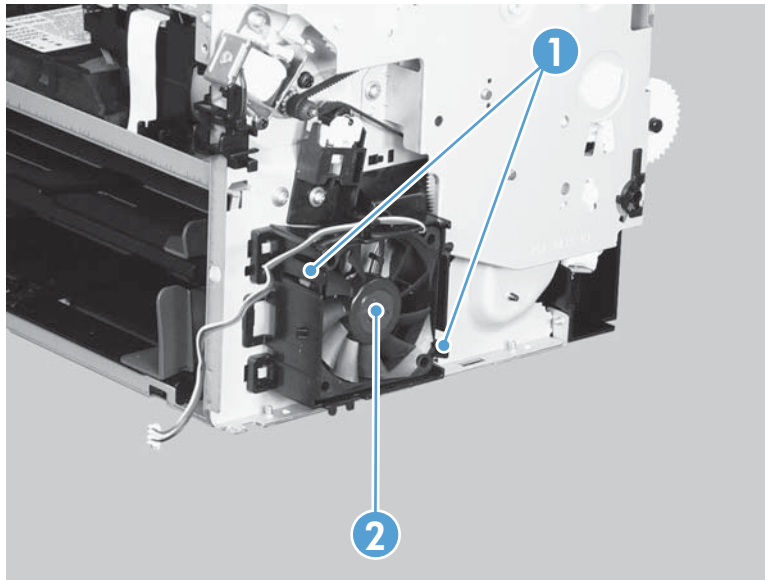

Reinstall the main fan

When the main fan is reinstalled, make sure that the wire harness (callout 1) is correctly positioned, and that the label (callout 2) on the fan faces the inside of the product.

Figure 1-156 Reinstall the main fan

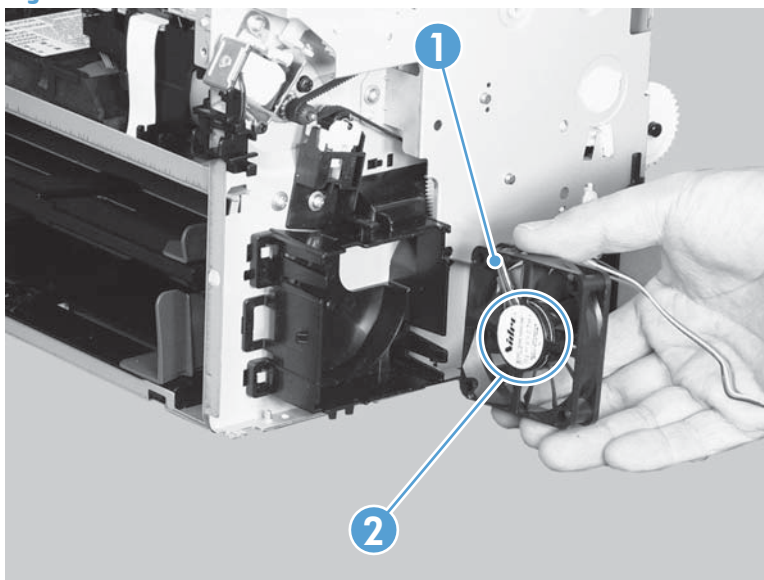

Duplex-connector PCA, duplex product

Before proceeding, remove the following components:

- Dust cover. See [Dust cover on page 11](#) or [Dust cover on page 36](#)
- Input tray assembly. See [Input tray assembly on page 11](#) or [Input tray assembly on page 36](#).
- Output tray assembly. See [Output tray assembly on page 11](#) or [Output tray assembly on page 37](#).
- Left cover. See [Left cover, duplex product on page 12](#) or [Left cover, simplex product on page 13](#) or [Left cover on page 37](#).
- Front cover assembly. See [Front cover assembly on page 15](#) or [Front cover assembly on page 38](#).
- Right cover. See [Right cover, duplex product on page 16](#) or [Right cover, simplex product on page 18](#) or [Right cover on page 40](#).
- Front cover assembly. See [Front cover assembly on page 15](#) or [Front cover assembly on page 38](#).

Remove the duplex-connector PCA

1. Release one tab (callout 1), and then remove the holder (callout 2).

Figure 1-157 Remove the duplex-connector PCA (1 of 5)

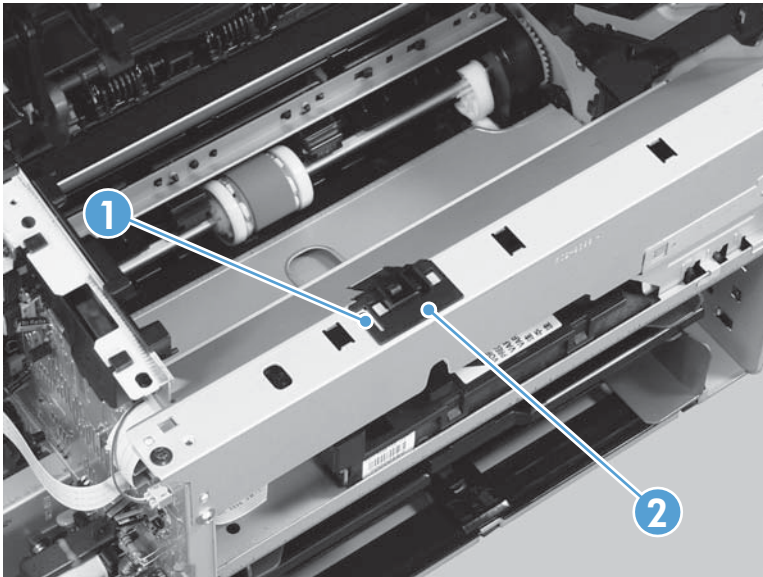

2. Remove four screws (callout 1), the scanner cover (callout 2) and the sheet-metal plate (callout 3).

 **NOTE:** The scanner cover and plate are removed as one assembly.

 **TIP:** When the cover is reinstalled, make sure that the black screws (callout 4) are installed in the correct screw holes.

Figure 1-158 Remove the duplex-connector PCA (2 of 5)



3. Disconnect three connectors (callout 1)

Figure 1-159 Remove the duplex-connector PCA (3 of 5)

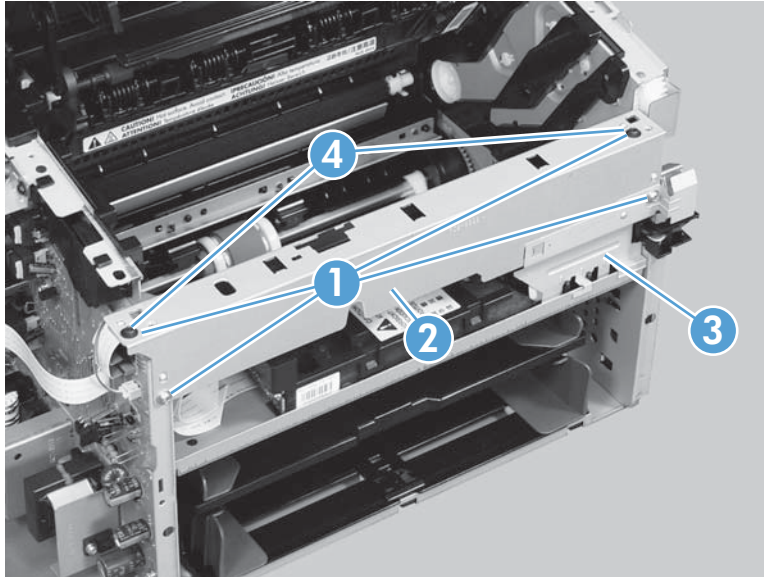
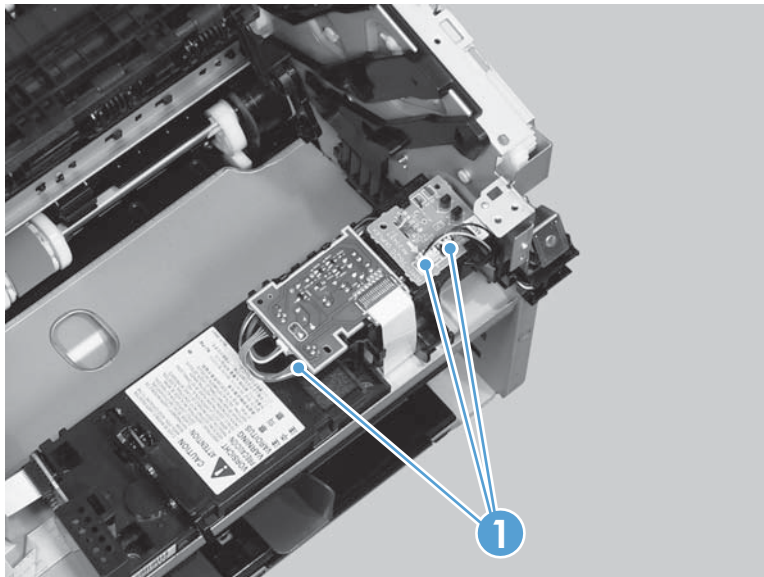

4. Release two tabs (callout 1), and then slightly separate the motor driver PCA (callout 2) from the product.

⚠ CAUTION: The motor driver PCA is still connected to the product by the wire harnesses and a FFC.

Figure 1-160 Remove the duplex-connector PCA (4 of 5)

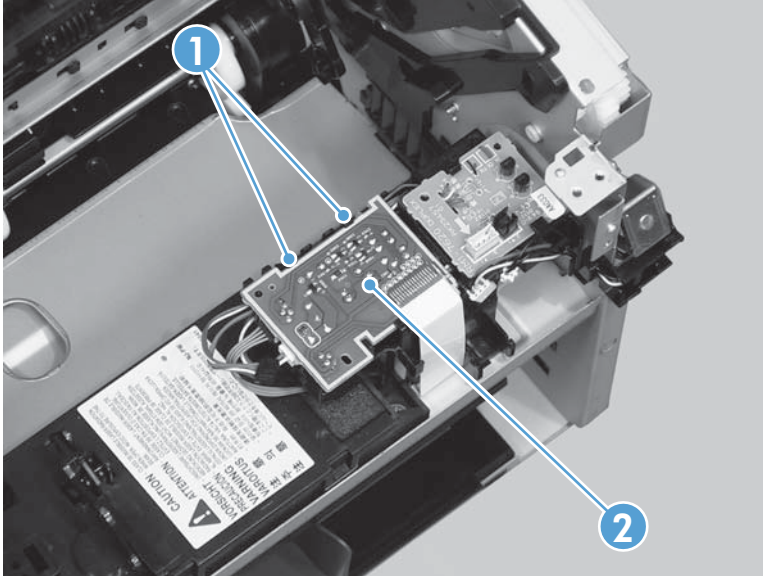

5. Release one tab (callout 1), and then remove the duplex-connector PCA (callout 2).

Figure 1-161 Remove the duplex-connector PCA (5 of 5)

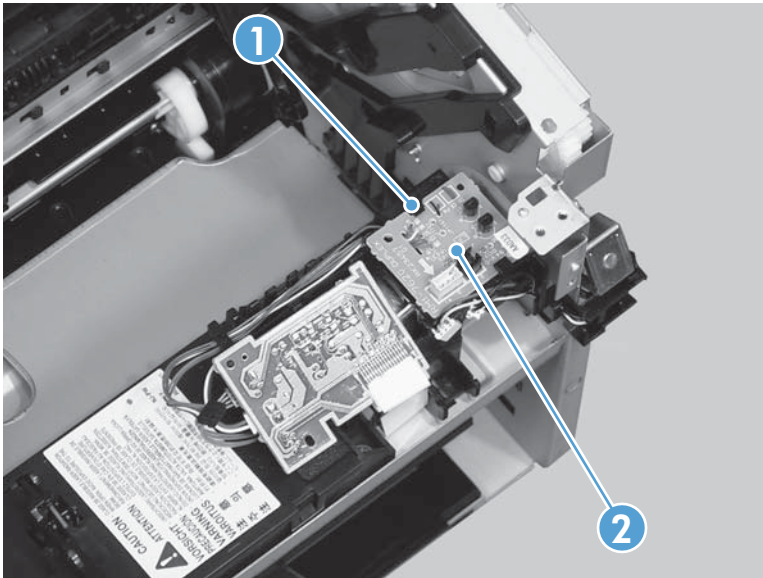

Automatic document feeder and scanner components



NOTE: This section describes replacement and removal of individual scanner components. To remove the complete scanner assembly, see [Scanner assembly on page 43](#).

Document feeder cover

1. Open the document feeder cover to the first click stop.

Figure 1-162 Remove the document feeder cover (1 of 3)



2. Carefully open the document feeder cover to the fully-open position.

Figure 1-163 Remove the document feeder cover (2 of 3)



3. Remove the document feeder cover (callout 1) by moving it toward the front of the product.

Figure 1-164 Remove the document feeder cover (3 of 3)

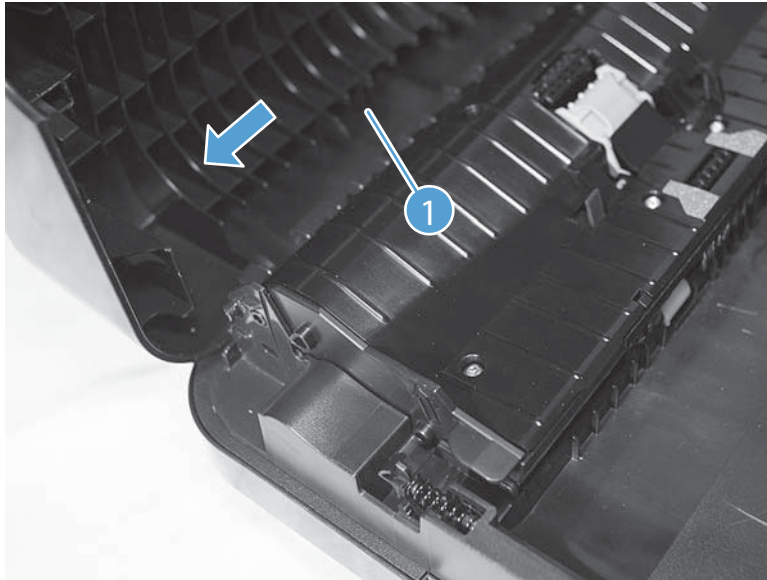

Document feeder pick arm assembly

Before proceeding, remove the following components:

- Document feeder cover. See [Document feeder cover on page 106](#).

Remove the document feeder pick arm assembly

1. Remove the pick extension shaft (callout 1).

Figure 1-165 Remove the document feeder pick arm assembly (1 of 3)

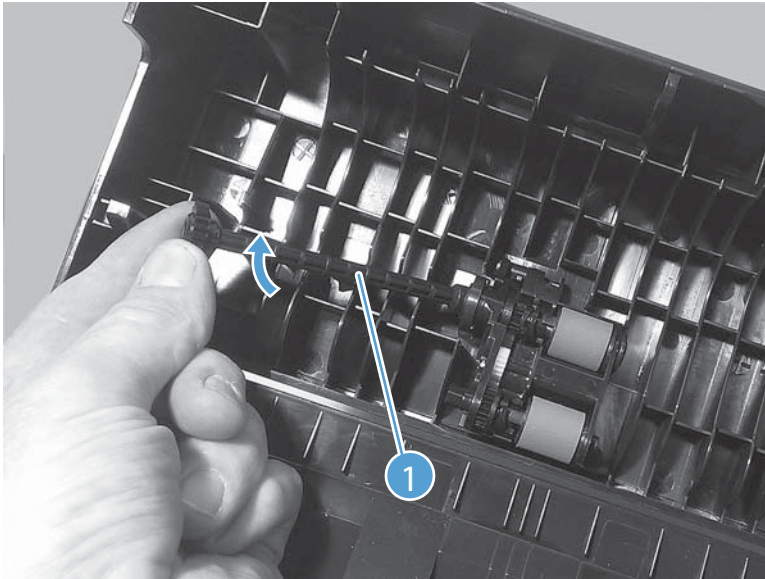

2. Release one tab (callout 1).

Figure 1-166 Remove the document feeder pick arm assembly (2 of 3)

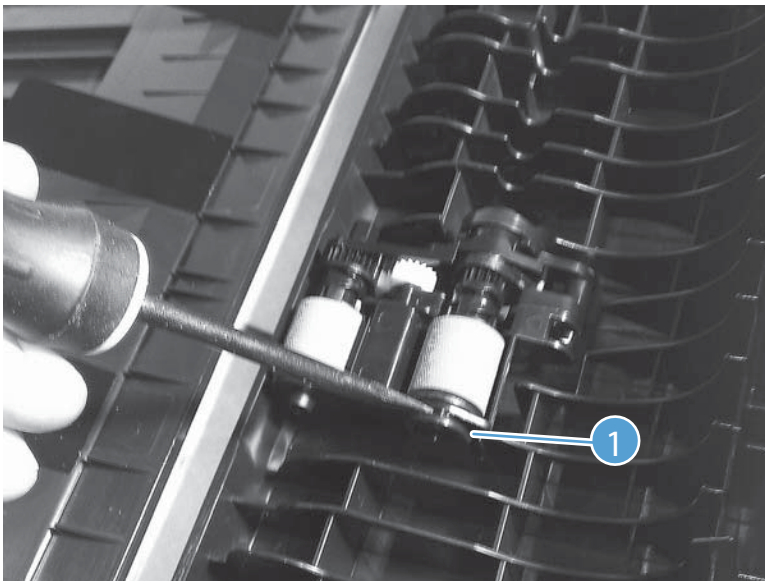

3. Disconnect the spring that is underneath the pick arm assembly (callout 1), and then rotate the pick arm assembly to remove it (callout 2).

Figure 1-167 Remove the document feeder pick arm assembly (3 of 3)

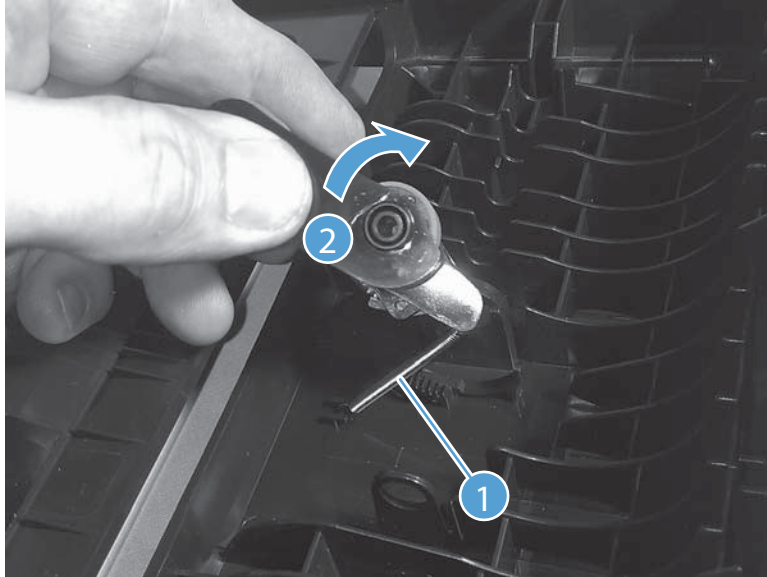

Document feeder core assembly

Before proceeding, remove the following component:

- Document feeder cover. See [Document feeder cover on page 106](#).

Remove the document feeder core assembly

1. Pinch and rotate the cable cover (callout 1) to remove it.

Figure 1-168 Remove the document feeder core assembly (1 of 5)

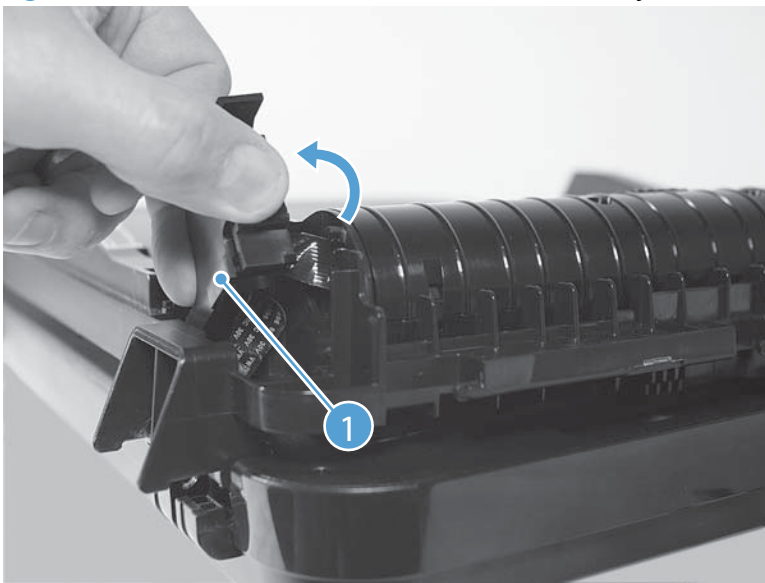

2. Remove one FFC using the blue tab (callout 1).

Figure 1-169 Remove the document feeder core assembly (2 of 5)

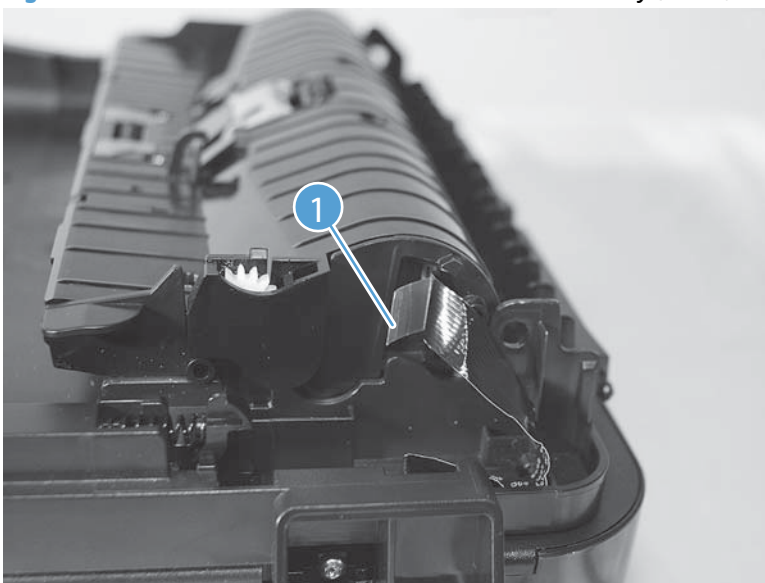

TIP: The orientation of the FFC is important. When reinstalling it, make sure the blue tab is toward the product right side. If the FFC is installed upside-down, the document feeder does not work.

3. Rotate the document feeder core assembly to the upright position.

Figure 1-170 Remove the document feeder core assembly (3 of 5)

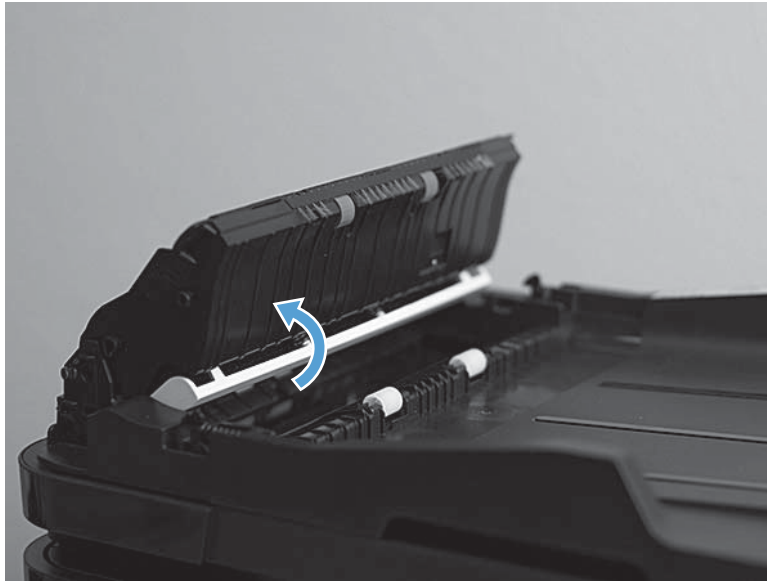

4. Release one tab (callout 1).

Figure 1-171 Remove the document feeder core assembly (4 of 5)

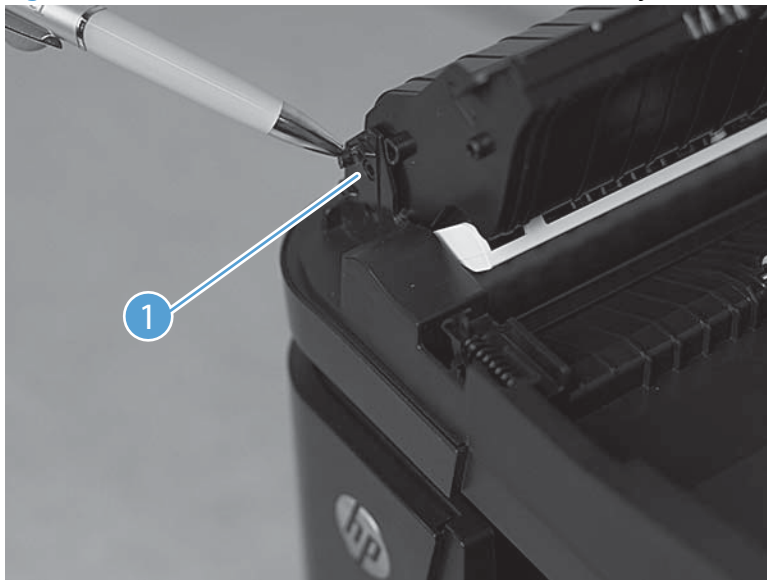

5. Remove the document feeder core assembly.

Figure 1-172 Remove the document feeder core assembly (5 of 5)

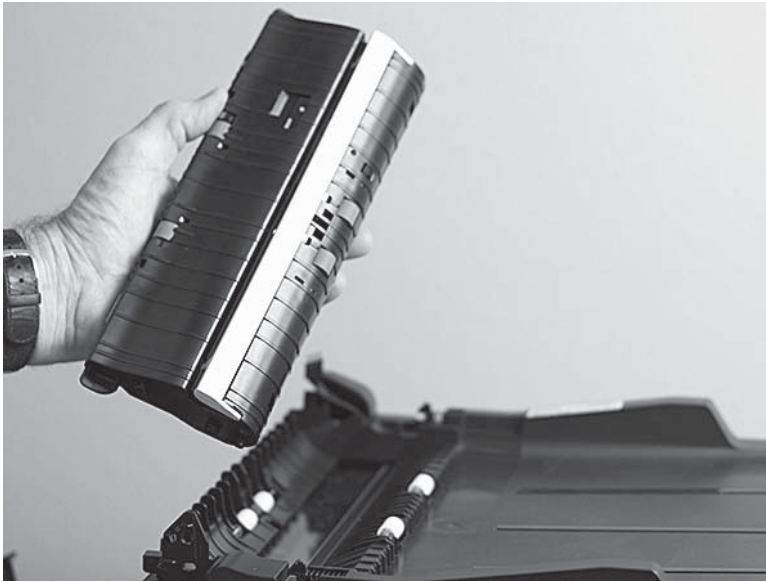

Post scan pinch rollers

Before proceeding, remove the following components:

- Document feeder cover. See [Document feeder cover on page 106](#).
- Document feeder core. See [Document feeder core assembly on page 110](#).

Remove the post scan pinch rollers

- ▲ Remove the post scan pinch rollers (callout 1).

Figure 1-173 Remove the post scan pinch rollers

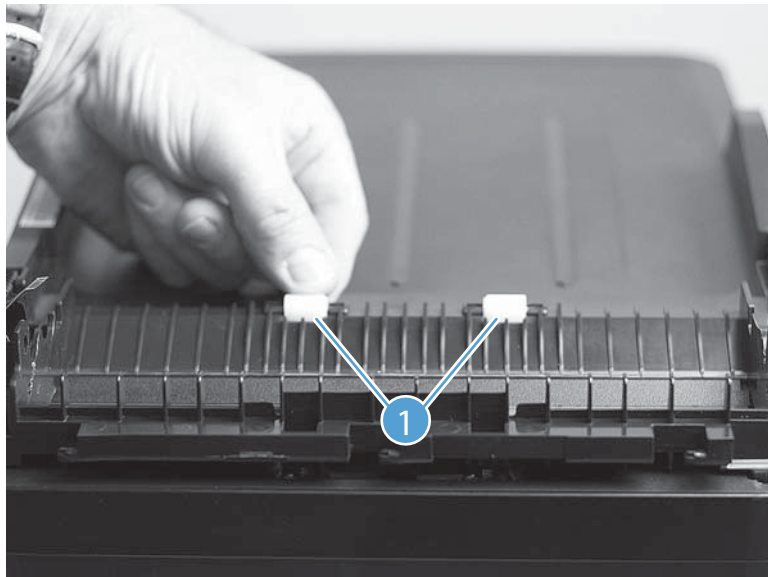

Document feeder base assembly

Before proceeding, remove the following components:

- Document feeder cover. See [Document feeder cover on page 106](#).
- Document feeder core. See [Document feeder core assembly on page 110](#).

Remove the document feeder base assembly

1. Remove two screws (callout 1).

Figure 1-174 Remove the document feeder base assembly (1 of 4)

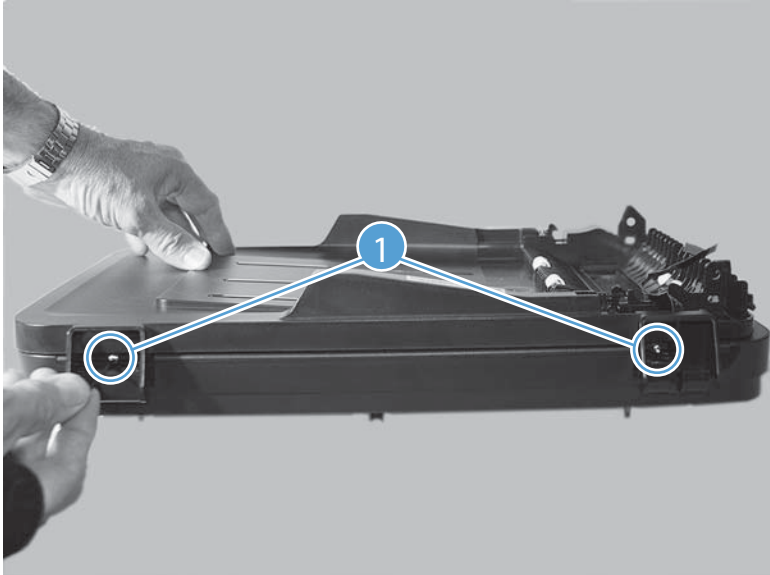

2. Open the document feeder base (callout 1) to the upright position.

Figure 1-175 Remove the document feeder base assembly (2 of 4)

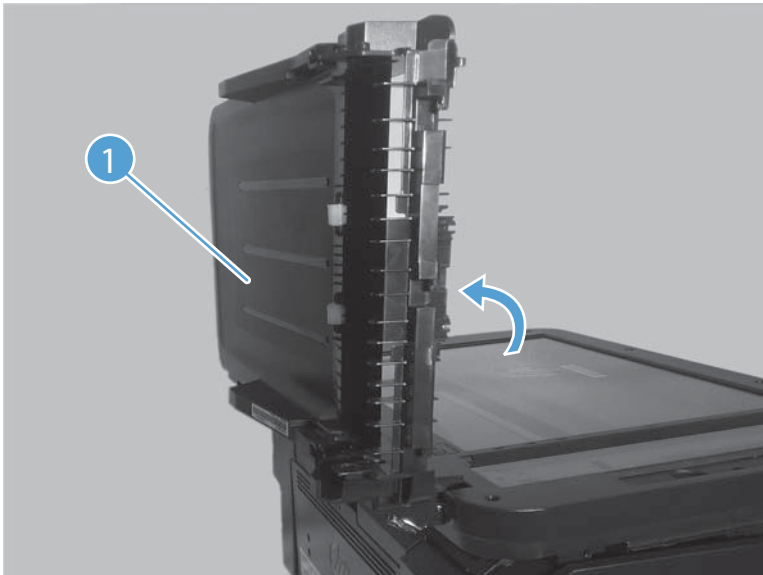

3. Lift the left side of the document feeder base, and then carefully remove the FFC (circled).

CAUTION: Do not damage the FFC (circled) that runs through the document feeder base. Carefully feed the FFC through the slot during removal and during replacement.

Figure 1-176 Remove the document feeder base assembly (3 of 4)



4. Temporarily set the left side of the document feeder base back onto its hinge, and then firmly lift the document feeder base straight up to remove it from the scanner base.

Figure 1-177 Remove the document feeder base assembly (4 of 4)



2 Parts and diagrams: HP LaserJet Pro M201/ M202 Printer series

- [Order parts by authorized service providers](#)
- [How to use the parts lists and diagrams](#)
- [Covers](#)
- [Internal assemblies](#)
- [Alphabetical parts list](#)
- [Numerical parts list](#)

Order parts by authorized service providers

Order replacement parts

Table 2-1 Order parts, accessories, and supplies

Order supplies and paper	www.hp.com/go/suresupply
Order genuine HP parts or accessories	www.hp.com/buy/parts
Order through service or support providers	Contact an HP-authorized service or support provider.

Related documentation

Table 2-2 Related documentation

Item	Description	Part number
<i>HP LaserJet Pro M201/M202 Printer series User Guide</i>	Product user guide.	Need part number
<i>HP LaserJet Pro M201/M202 Printer series Service Manual</i>	English service manual (this manual)	N/A

Supplies part numbers

Table 2-3 Supplies part numbers

Item	Cartridge number	Part number (service)
High-capacity black toner cartridge, HP LaserJet Pro M201 series	CF283X	CF484-67903
Standard-capacity black toner cartridge, HP LaserJet Pro M201 series	CF283A	CF283-67902
Standard-capacity black toner cartridge, HP LaserJet Pro M202 series	CC388A	CC388-67901

Customer self repair parts

Table 2-4 Customer replaceable units (CRU) kit part numbers

Description	Part number
Separation pad assembly	RM1-4227-000
Kit, pickup roller	RL1-3642-000
Dust cover	RC3-3902-000
Paper delivery tray assembly	RM1-9649-000
Paper pickup tray assembly	RM1-9677-000

Service parts

 **NOTE:** The parts in the following table are not shown in the assembly illustrations in this chapter.

Description	Part number
PCA-Formatter Wireless WW (wireless products only)	CZ229-60001
UMBER 802.11N DUAL BAND STRA CONN (wireless products only)	1150-7957

Whole-unit replacement part numbers

 **NOTE:** Whole-unit replacement products include the formatter PCA.

Table 2-5 Whole-unit replacement part numbers

Description	Part number
Product-Replacement 220V M201N AP	CF455-67902
Product-Exchange 220V M201N EU	CF455-69002
Product-Replacement 220V M201DW AP	CF456-67901
Product-Exchange 220V M201DW EU	CF456-69001
Product-Replacement 220V M202N CH	C6N20-67901
Product-Replacement 220V M202N IN	C6N20-67902
Product-Replacement 220V M202DW CH	C6N21-67903
Product-Replacement 220V M202DW IN	C6N21-67904

How to use the parts lists and diagrams

 **CAUTION:** Be sure to order the correct part. When looking for part numbers for electrical components, pay careful attention to the voltage that is listed. Doing so will make sure that the part number selected is for the correct model.

 **NOTE:** In this manual, the abbreviation “PCA” stands for “printed circuit-board assembly.” Components described as a PCA might consist of a single circuit board or a circuit board plus other parts, such as cables and sensors.

The figures in this chapter show the major subassemblies in the product and their component parts. A parts list table follows each exploded view assembly diagram. Each table lists the item number, the associated part number, and the description of each part. If a part is not listed in the table, then it is not a field replacement unit (FRU).

Covers

Duplex product

Figure 2-1 External panels and covers, duplex product

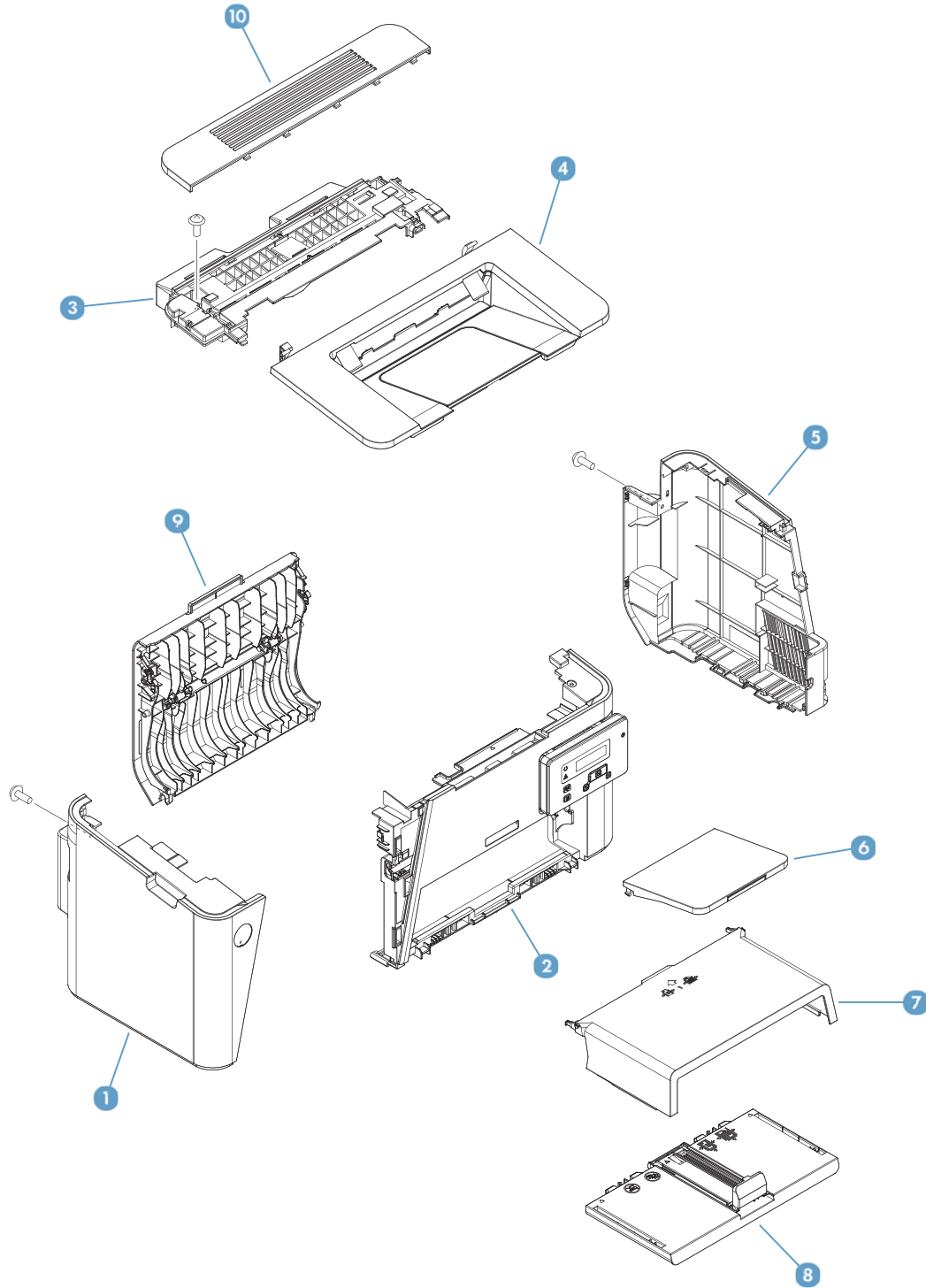

Table 2-6 External panels and covers, duplex product

Ref	Description	Part number	Qty
1	Cover, left (duplex product)	RL1-3671-000	1
2	Front cover assembly (duplex product)	RM2-0411-000	1
3	Cover, top (duplex product)	RC3-3898-000	1
4	Cartridge door assembly	RM1-9652-000	1
5	Cover, right (duplex product)	RC3-3900-000	1
6	Paper delivery tray assembly	RM1-9649-000	1
7	Cover, dust	RC3-3902-000	1
8	Paper pick-up tray assembly	RM1-9677-000	1
9	Duplexing door assembly	RM1-9654-000	1
10	Cap (duplex product)	RC3-3923-000	1

Simplex product

Figure 2-2 External panels and covers, simplex product

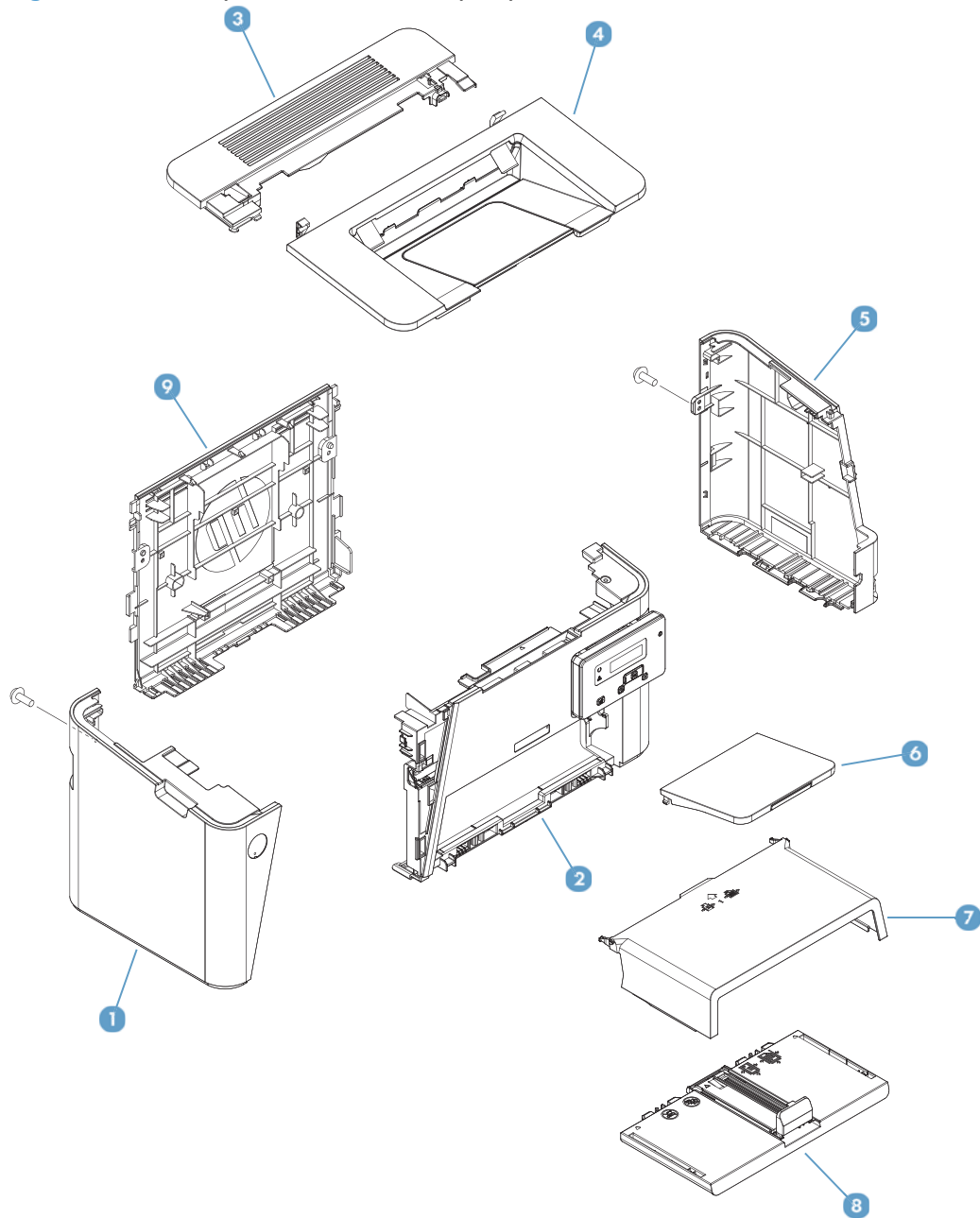

Table 2-7 External panels and covers, simplex product

Ref	Description	Part number	Qty
1	Cover, left (simplex product)	RL1-4079-000	1
2	Front cover assembly (simplex product)	RM2-0414-000	1
3	Cover, top (simplex product)	RC3-3899-000	1
4	Cartridge door assembly	RM1-9652-000	1
5	Cover, right (simplex product)	RC3-3901-000	1
6	Paper delivery tray assembly	RM1-9649-000	1
7	Cover, dust	RC3-3902-000	1
8	Paper pick-up tray assembly	RM1-9677-000	1
9	Cover, rear (simplex product)	RL1-3666-000	1

Internal assemblies

Internal assemblies (1 of 3)

Figure 2-3 Internal assemblies (1 of 3)

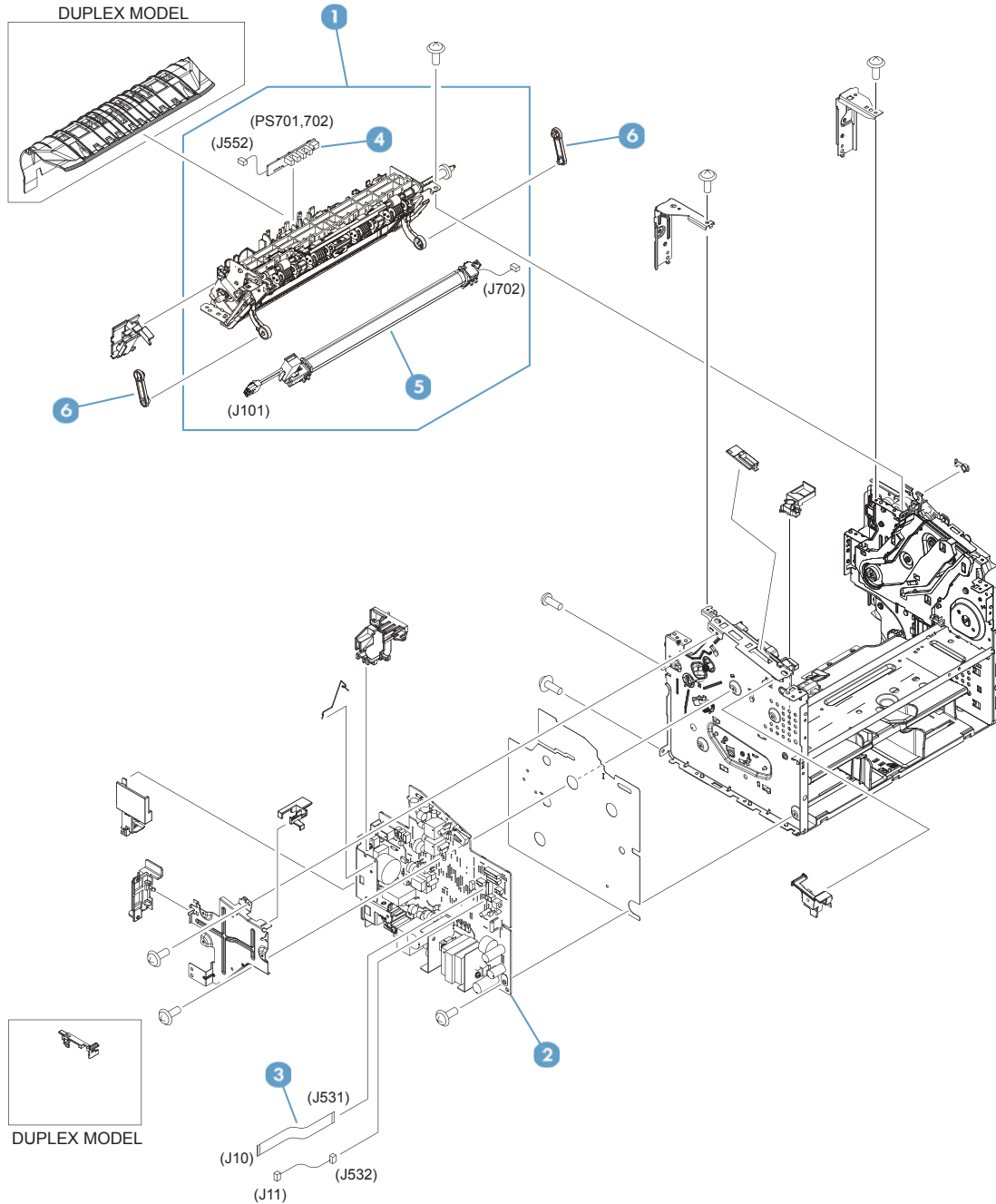

Table 2-8 Internal assemblies (1 of 3)

Ref	Description	Part number	Qty
1	Fixing assembly, 110-127V	RM1-9658-000	1
1	Fixing assembly, 220-240V	RM1-9659-000	1
2	Engine control PCB assembly, 110-127V	RM2-7605-000	1
2	Engine control PCB assembly, 220-240V	RM2-7606-000	1
2	Engine control PCB assembly, 220-240V, CH IN	RM2-8079-000	1
3	Cable,flat	RK2-6680-000	1
4	Delivery sensor PCB assembly	RM2-7629-000	1
5	Fixing film assembly, 110-127V	RM1-9656-000	1
5	Fixing film assembly, 220-240V	RM1-9657-000	1
6	Link, pressure release	RC2-9512-000	2

Internal assemblies (2 of 3)

Figure 2-4 Internal assemblies (2 of 3)

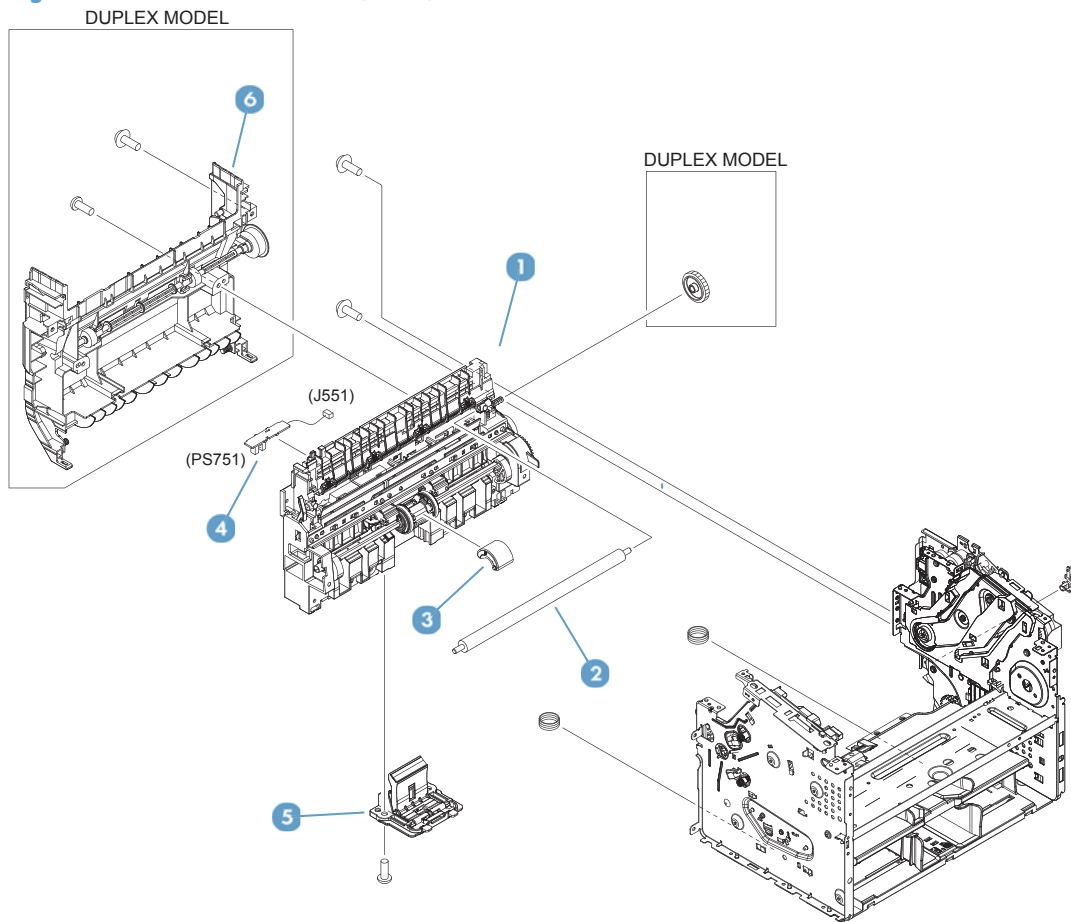

Table 2-9 Internal assemblies (2 of 3)

Ref	Description	Part number	Qty
1	Paper pick-up assembly (duplex product)	RM2-6524-000	1
1	Paper pick-up assembly (simplex product)	RM2-6525-000	1
2	Roller, transfer	RM1-4023-000	1
3	Roller, pickup	RL1-3642-000	1
4	Paper pick-up sensor PCB assembly	RM2-7609-000	1
5	Separation pad assembly	RM1-4227-000	1
6	Duplexing frame assembly	RM1-9655-000	1

Internal assemblies (3 of 3)

Figure 2-5 Internal assemblies (3 of 3)

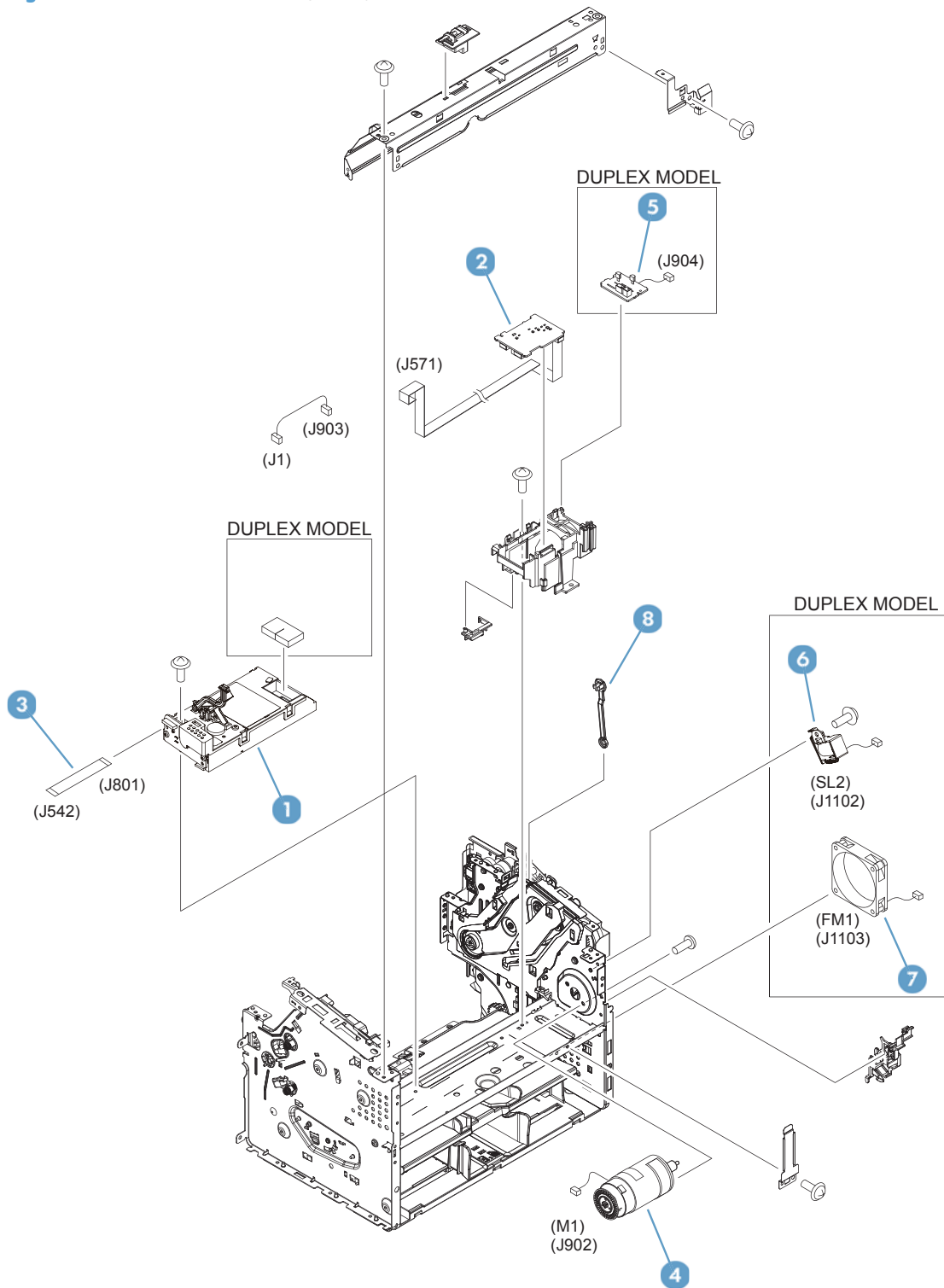

Table 2-10 Internal assemblies (3 of 3)

Ref	Description	Part number	Qty
1	Laser scanner assembly	RM2-0426-000	1
2	Motor PCB assembly	RM2-7607-000	1
3	Cable, flat	RK2-6691-000	1
4	Motor, DC24V	RM2-0418-000	1
5	Duplexing PCB assembly (duplex product)	RM2-7608-000	1
6	Solenoid (duplex product)	RK2-0420-000	1
7	Fan (duplex product)	RK2-6694-000	1
8	Link, cartridge door	RC2-9425-000	1

Alphabetical parts list

Table 2-11 Alphabetical parts list

Description	Part number	Table and page
Cable, flat	RK2-6691-000	Internal assemblies (3 of 3) on page 131
Cable,flat	RK2-6680-000	Internal assemblies (1 of 3) on page 127
Cap (duplex product)	RC3-3923-000	External panels and covers, duplex product on page 123
Cartridge door assembly	RM1-9652-000	External panels and covers, duplex product on page 123
Cartridge door assembly	RM1-9652-000	External panels and covers, simplex product on page 125
Cover, dust	RC3-3902-000	External panels and covers, duplex product on page 123
Cover, dust	RC3-3902-000	External panels and covers, simplex product on page 125
Cover, left (duplex product)	RL1-3671-000	External panels and covers, duplex product on page 123
Cover, left (simplex product)	RL1-4079-000	External panels and covers, simplex product on page 125
Cover, rear (simplex product)	RL1-3666-000	External panels and covers, simplex product on page 125
Cover, right (duplex product)	RC3-3900-000	External panels and covers, duplex product on page 123
Cover, right (simplex product)	RC3-3901-000	External panels and covers, simplex product on page 125
Cover, top (duplex product)	RC3-3898-000	External panels and covers, duplex product on page 123
Cover, top (simplex product)	RC3-3899-000	External panels and covers, simplex product on page 125
Delivery sensor PCB assembly	RM2-7629-000	Internal assemblies (1 of 3) on page 127
Duplexing door assembly	RM1-9654-000	External panels and covers, duplex product on page 123
Duplexing frame assembly	RM1-9655-000	Internal assemblies (2 of 3) on page 129
Duplexing PCB assembly (duplex product)	RM2-7608-000	Internal assemblies (3 of 3) on page 131
Engine control PCB assembly, 110-127V	RM2-7605-000	Internal assemblies (1 of 3) on page 127
Engine control PCB assembly, 220-240V	RM2-7606-000	Internal assemblies (1 of 3) on page 127

Table 2-11 Alphabetical parts list (continued)

Description	Part number	Table and page
Engine control PCB assembly, 220-240V, CH IN	RM2-8079-000	Internal assemblies (1 of 3) on page 127
Fan (duplex product)	RK2-6694-000	Internal assemblies (3 of 3) on page 131
Fixing assembly, 110-127V	RM1-9658-000	Internal assemblies (1 of 3) on page 127
Fixing assembly, 220-240V	RM1-9659-000	Internal assemblies (1 of 3) on page 127
Fixing film assembly, 110-127V	RM1-9656-000	Internal assemblies (1 of 3) on page 127
Fixing film assembly, 220-240V	RM1-9657-000	Internal assemblies (1 of 3) on page 127
Front cover assembly (duplex product)	RM2-0411-000	External panels and covers, duplex product on page 123
Front cover assembly (simplex product)	RM2-0414-000	External panels and covers, simplex product on page 125
Laser scanner assembly	RM2-0426-000	Internal assemblies (3 of 3) on page 131
Link, cartridge door	RC2-9425-000	Internal assemblies (3 of 3) on page 131
Link, pressure release	RC2-9512-000	Internal assemblies (1 of 3) on page 127
Motor PCB assembly	RM2-7607-000	Internal assemblies (3 of 3) on page 131
Motor, DC24V	RM2-0418-000	Internal assemblies (3 of 3) on page 131
Paper delivery tray assembly	RM1-9649-000	External panels and covers, duplex product on page 123
Paper delivery tray assembly	RM1-9649-000	External panels and covers, simplex product on page 125
Paper pick-up assembly (duplex product)	RM2-6524-000	Internal assemblies (2 of 3) on page 129
Paper pick-up assembly (simplex product)	RM2-6525-000	Internal assemblies (2 of 3) on page 129
Paper pick-up sensor PCB assembly	RM2-7609-000	Internal assemblies (2 of 3) on page 129
Paper pick-up tray assembly	RM1-9677-000	External panels and covers, duplex product on page 123
Paper pick-up tray assembly	RM1-9677-000	External panels and covers, simplex product on page 125
Roller, pickup	RL1-3642-000	Internal assemblies (2 of 3) on page 129

Table 2-11 Alphabetical parts list (continued)

Description	Part number	Table and page
Roller, transfer	RM1-4023-000	Internal assemblies (2 of 3) on page 129
Separation pad assembly	RM1-4227-000	Internal assemblies (2 of 3) on page 129
Solenoid (duplex product)	RK2-0420-000	Internal assemblies (3 of 3) on page 131

Numerical parts list

Table 2-12 Numerical parts list

Part number	Description	Table and page
RC2-9425-000	Link, cartridge door	Internal assemblies (3 of 3) on page 131
RC2-9512-000	Link, pressure release	Internal assemblies (1 of 3) on page 127
RC3-3898-000	Cover, top (duplex product)	External panels and covers, duplex product on page 123
RC3-3899-000	Cover, top (simplex product)	External panels and covers, simplex product on page 125
RC3-3900-000	Cover, right (duplex product)	External panels and covers, duplex product on page 123
RC3-3901-000	Cover, right (simplex product)	External panels and covers, simplex product on page 125
RC3-3902-000	Cover, dust	External panels and covers, duplex product on page 123
RC3-3902-000	Cover, dust	External panels and covers, simplex product on page 125
RC3-3923-000	Cap (duplex product)	External panels and covers, duplex product on page 123
RK2-0420-000	Solenoid (duplex product)	Internal assemblies (3 of 3) on page 131
RK2-6680-000	Cable, flat	Internal assemblies (1 of 3) on page 127
RK2-6691-000	Cable, flat	Internal assemblies (3 of 3) on page 131
RK2-6694-000	Fan (duplex product)	Internal assemblies (3 of 3) on page 131
RL1-3642-000	Roller, pickup	Internal assemblies (2 of 3) on page 129
RL1-3666-000	Cover, rear (simplex product)	External panels and covers, simplex product on page 125
RL1-3671-000	Cover, left (duplex product)	External panels and covers, duplex product on page 123
RL1-4079-000	Cover, left (simplex product)	External panels and covers, simplex product on page 125
RM1-4023-000	Roller, transfer	Internal assemblies (2 of 3) on page 129
RM1-4227-000	Separation pad assembly	Internal assemblies (2 of 3) on page 129
RM1-9649-000	Paper delivery tray assembly	External panels and covers, duplex product on page 123

Table 2-12 Numerical parts list (continued)

Part number	Description	Table and page
RM1-9649-000	Paper delivery tray assembly	External panels and covers, simplex product on page 125
RM1-9652-000	Cartridge door assembly	External panels and covers, duplex product on page 123
RM1-9652-000	Cartridge door assembly	External panels and covers, simplex product on page 125
RM1-9654-000	Duplexing door assembly	External panels and covers, duplex product on page 123
RM1-9655-000	Duplexing frame assembly	Internal assemblies (2 of 3) on page 129
RM1-9656-000	Fixing film assembly, 110-127V	Internal assemblies (1 of 3) on page 127
RM1-9657-000	Fixing film assembly, 220-240V	Internal assemblies (1 of 3) on page 127
RM1-9658-000	Fixing assembly, 110-127V	Internal assemblies (1 of 3) on page 127
RM1-9659-000	Fixing assembly, 220-240V	Internal assemblies (1 of 3) on page 127
RM1-9677-000	Paper pick-up tray assembly	External panels and covers, duplex product on page 123
RM1-9677-000	Paper pick-up tray assembly	External panels and covers, simplex product on page 125
RM2-0411-000	Front cover assembly (duplex product)	External panels and covers, duplex product on page 123
RM2-0414-000	Front cover assembly (simplex product)	External panels and covers, simplex product on page 125
RM2-0418-000	Motor, DC24V	Internal assemblies (3 of 3) on page 131
RM2-0426-000	Laser scanner assembly	Internal assemblies (3 of 3) on page 131
RM2-6524-000	Paper pick-up assembly (duplex product)	Internal assemblies (2 of 3) on page 129
RM2-6525-000	Paper pick-up assembly (simplex product)	Internal assemblies (2 of 3) on page 129
RM2-7605-000	Engine control PCB assembly, 110-127V	Internal assemblies (1 of 3) on page 127
RM2-7606-000	Engine control PCB assembly, 220-240V	Internal assemblies (1 of 3) on page 127
RM2-7607-000	Motor PCB assembly	Internal assemblies (3 of 3) on page 131
RM2-7608-000	Duplexing PCB assembly (duplex product)	Internal assemblies (3 of 3) on page 131

Table 2-12 Numerical parts list (continued)

Part number	Description	Table and page
RM2-7609-000	Paper pick-up sensor PCB assembly	Internal assemblies (2 of 3) on page 129
RM2-7629-000	Delivery sensor PCB assembly	Internal assemblies (1 of 3) on page 127
RM2-8079-000	Engine control PCB assembly, 220-240V, CH IN	Internal assemblies (1 of 3) on page 127

3 Parts and diagrams: HP LaserJet Pro MFP M225/M226 series

- [Order parts by authorized service providers](#)
- [How to use the parts lists and diagrams](#)
- [Covers](#)
- [Internal assemblies](#)
- [Scanner and document feeder \(ADF\)](#)
- [Scanner assembly internal components](#)
- [Alphabetical parts list](#)
- [Numerical parts list](#)

Order parts by authorized service providers

Order replacement parts

Table 3-1 Order parts, accessories, and supplies

Order supplies and paper	www.hp.com/go/suresupply
Order genuine HP parts or accessories	www.hp.com/buy/parts
Order through service or support providers	Contact an HP-authorized service or support provider.

Related documentation

Table 3-2 Related documentation

Item	Description	Part number
<i>HP LaserJet Pro MFP M225/M226 Printer series User Guide</i>	Product user guide.	Need part number
<i>HP LaserJet Pro M201/M202 Printer series Service Manual</i>	English service manual (this manual)	N/A

Supplies part numbers

Table 3-3 Supplies part numbers

Item	Cartridge number	Part number (service)
High-capacity black toner cartridge, HP LaserJet Pro MFP M225 series	CF283X	CF484-67903
Standard-capacity black toner cartridge, HP LaserJet Pro MFP M225 series	CF283A	CF283-67902
Standard-capacity black toner cartridge, HP LaserJet Pro MFP M226 series	CC388A	CC388-67901

Customer self repair parts

Table 3-4 Customer replaceable units (CRU) kit part numbers

Description	Part number
Separation pad assembly	RM1-4227-000
Kit, pickup roller	RL1-3642-000
Dust cover	RC3-3902-000
Paper delivery tray assembly	RM1-9649-000
Paper pickup tray assembly	RM1-9677-000

Service parts

 **NOTE:** The parts in the following table are not shown in the assembly illustrations in this chapter.

Description	Part number
Scanner:	
Assembly, scanner/ADF (bulkpack)	CF484-60106
1200PPI scanner assembly ¹	D1527-60002
Assembly, motor scanner ¹	CN503-60006
ADF:	
Assembly, ADF top cover	CF484-60117
Control panel, WiFi, and fax:	
Assembly, two-line control panel 4:1 (dn products)	CF484-60115
Assembly, magic frame 3.0 inch (dw products)	CF484-60122
PCA, formatter network	CZ231-60001
PCA, formatter wireless	CZ232-60001
PCA, fax card US	CF206-60001
WiFi board, Umber	1150-7959
Fax rubber cap	CZ185-40001

¹ Part must be replaced in a dust-free chamber.

Whole-unit replacement part numbers

 **NOTE:** Whole-unit replacement products include the formatter PCA.

Table 3-5 Whole-unit replacement part numbers

Description	Part number
Product-Replacement 110V M225DN NA/TW	CF484-67901

Table 3-5 Whole-unit replacement part numbers (continued)

Description	Part number
Product-Exchange 110V M225DN NA/TW	CF484-69001
Product-Replacement 220V M225DN AP	CF484-67902
Product-Exchange 220V M225DN EU	CF484-69002
Product-Replacement 220V M226DN CH	C6N22-67901
Product-Replacement 110V M225DW NA/TW	CF485-67901
Product-Exchange 110V M225DW NA/TW	CF484-69003
Product-Replacement 220V M225DW AP	CF485-67902
Product-Exchange 220V M225DW EU	CF484-69004
Product-Exchange 220V M226DN CH	C6N22-69001
Product-Replacement 220V M226DN IN	C6N22-67902
Product-Replacement 220V M226DW CH	C6N23-67901
Product-Exchange 220V M226DW CH	C6N22-69002
Product-Replacement 220V M226DW IN	C6N23-67902

How to use the parts lists and diagrams

 **CAUTION:** Be sure to order the correct part. When looking for part numbers for electrical components, pay careful attention to the voltage that is listed. Doing so will make sure that the part number selected is for the correct model.

 **NOTE:** In this manual, the abbreviation “PCA” stands for “printed circuit-board assembly.” Components described as a PCA might consist of a single circuit board or a circuit board plus other parts, such as cables and sensors.

The figures in this chapter show the major subassemblies in the product and their component parts. A parts list table follows each exploded view assembly diagram. Each table lists the item number, the associated part number, and the description of each part. If a part is not listed in the table, then it is not a field replacement unit (FRU).

Covers

Figure 3-1 External panels and covers

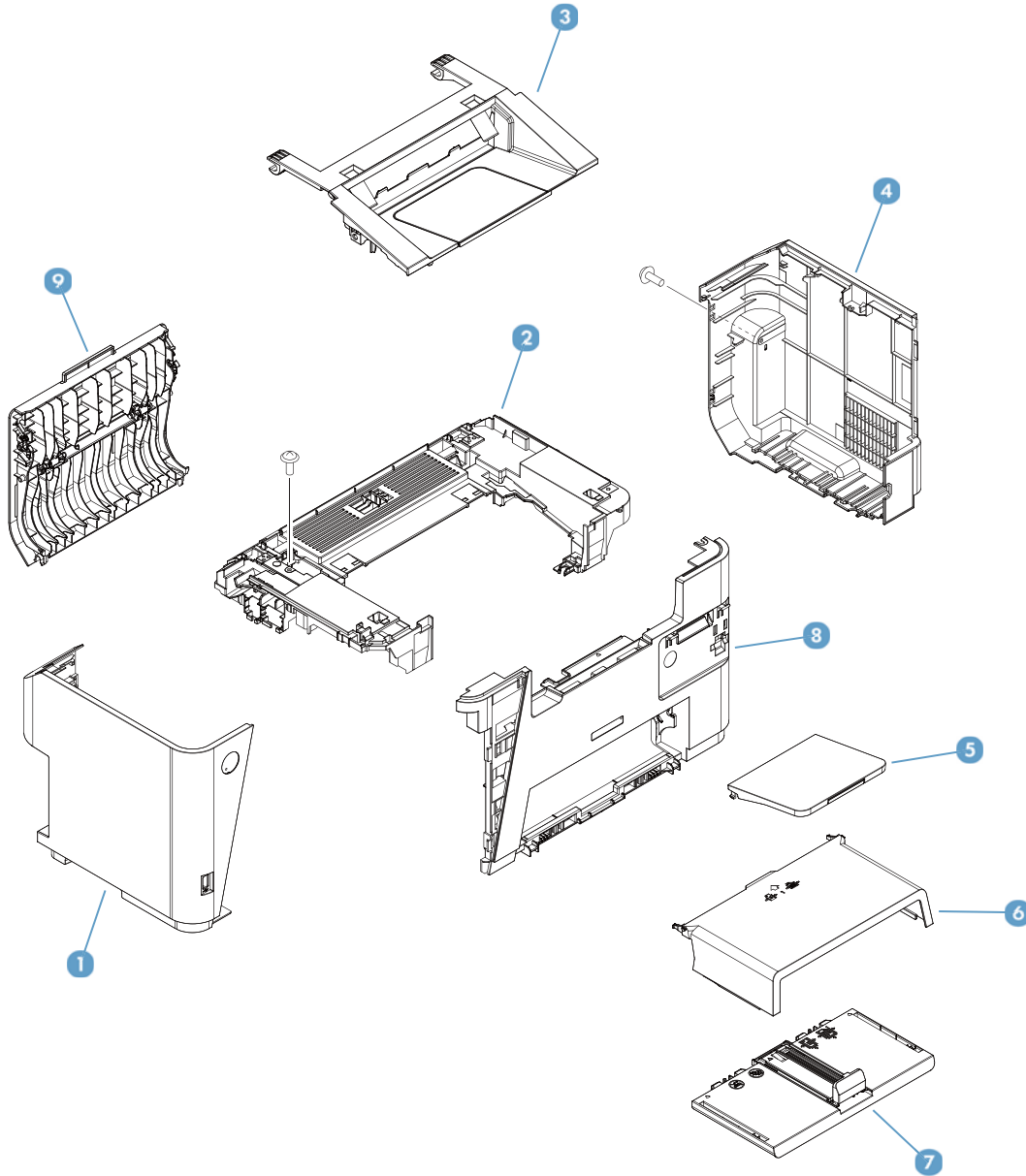

Table 3-6 External panels and covers

Ref	Description	Part number	Qty
1	Cover, left	RL1-3803-000	1
2	Cover, top	RC3-4790-000	1
3	Cartridge door assembly	RM1-9890-000	1
4	Cover, right	RC3-4792-000	1
5	Paper delivery tray assembly	RM1-9649-000	1
6	Cover, dust	RC3-3902-000	1
7	Paper pick-up tray assembly	RM1-9677-000	1
8	Cover, front	RL1-3802-000	1
9	Duplexing door assembly	RM1-9654-000	1

Internal assemblies

Internal assemblies (1 of 3)

Figure 3-2 Internal assemblies (1 of 3)

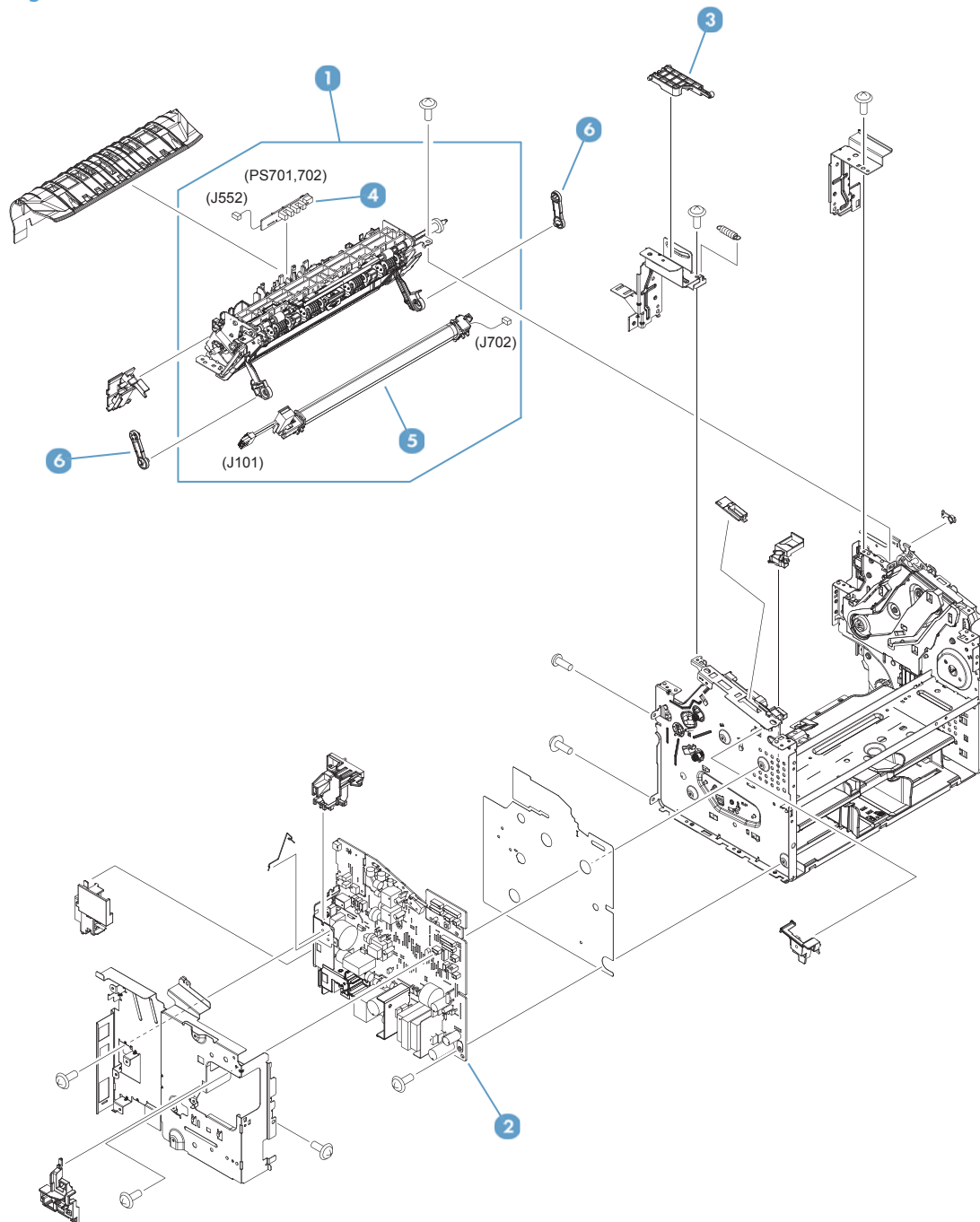

Table 3-7 Internal assemblies (1 of 3)

Ref	Description	Part number	Qty
1	Fixing assembly, 110-127V	RM1-9891-000	1
1	Fixing assembly, 220-240V	RM1-9892-000	1
2	Engine control PCB assembly, 110-127V	RM2-7632-000	1
2	Engine control PCB assembly, 220-240V	RM2-7633-000	1
2	Engine control PCB assembly, 220-240V, CH IN	RM2-8080-000	1
3	Link, cartridge door	RC2-9527-000	1
4	Delivery sensor PCB assembly	RM2-7629-000	1
5	Fixing film assembly, 110-127V	RM1-9656-000	1
5	Fixing film assembly, 220-240V	RM1-9657-000	1
6	Link, pressure release	RC2-9531-000	2

Internal assemblies (2 of 3)

Figure 3-3 Internal assemblies (2 of 3)

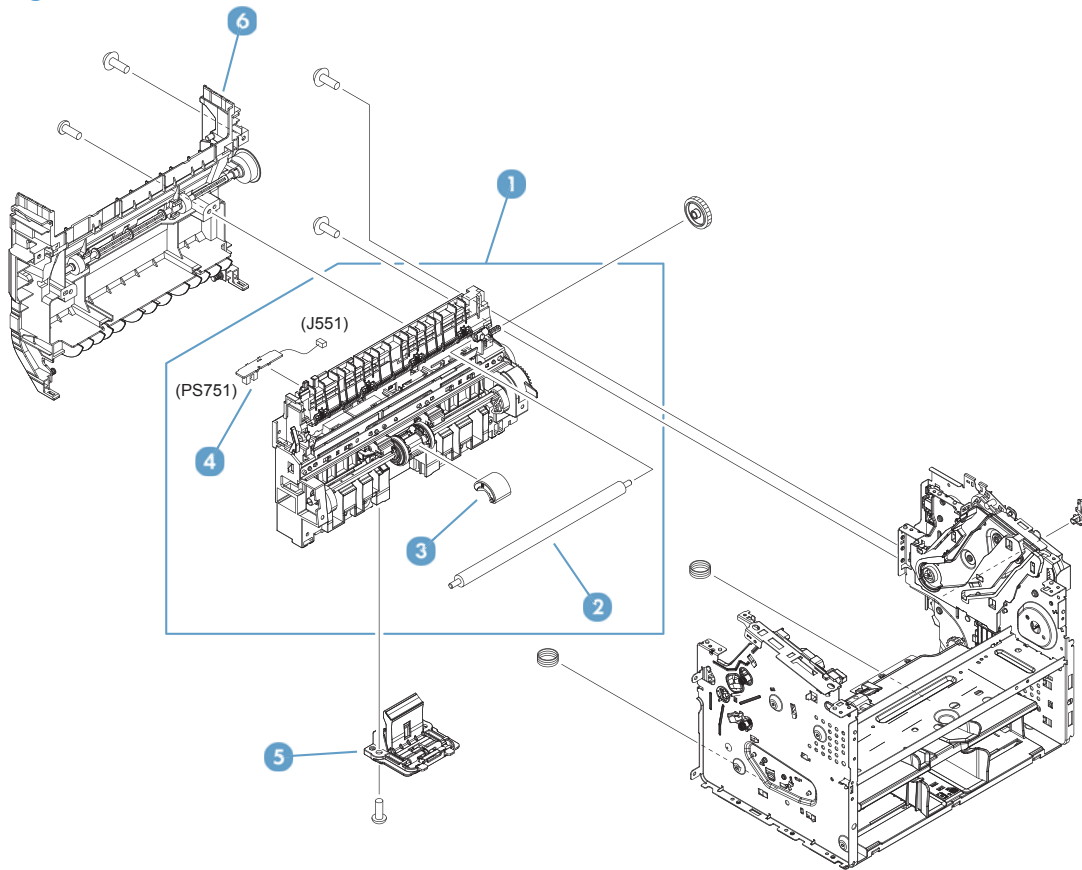

Table 3-8 Internal assemblies (2 of 3)

Ref	Description	Part number	Qty
1	Paper pick-up assembly	RM2-6524-000	1
2	Roller, transfer	RM1-4023-000	1
3	Roller, pickup	RL1-3642-000	1
4	Paper pick-up sensor PCB assembly	RM2-7635-000	1
5	Separation pad assembly	RM1-4227-000	1
6	Duplexing frame assembly	RM1-9655-000	1

Internal assemblies (3 of 3)

Figure 3-4 Internal assemblies (3 of 3)

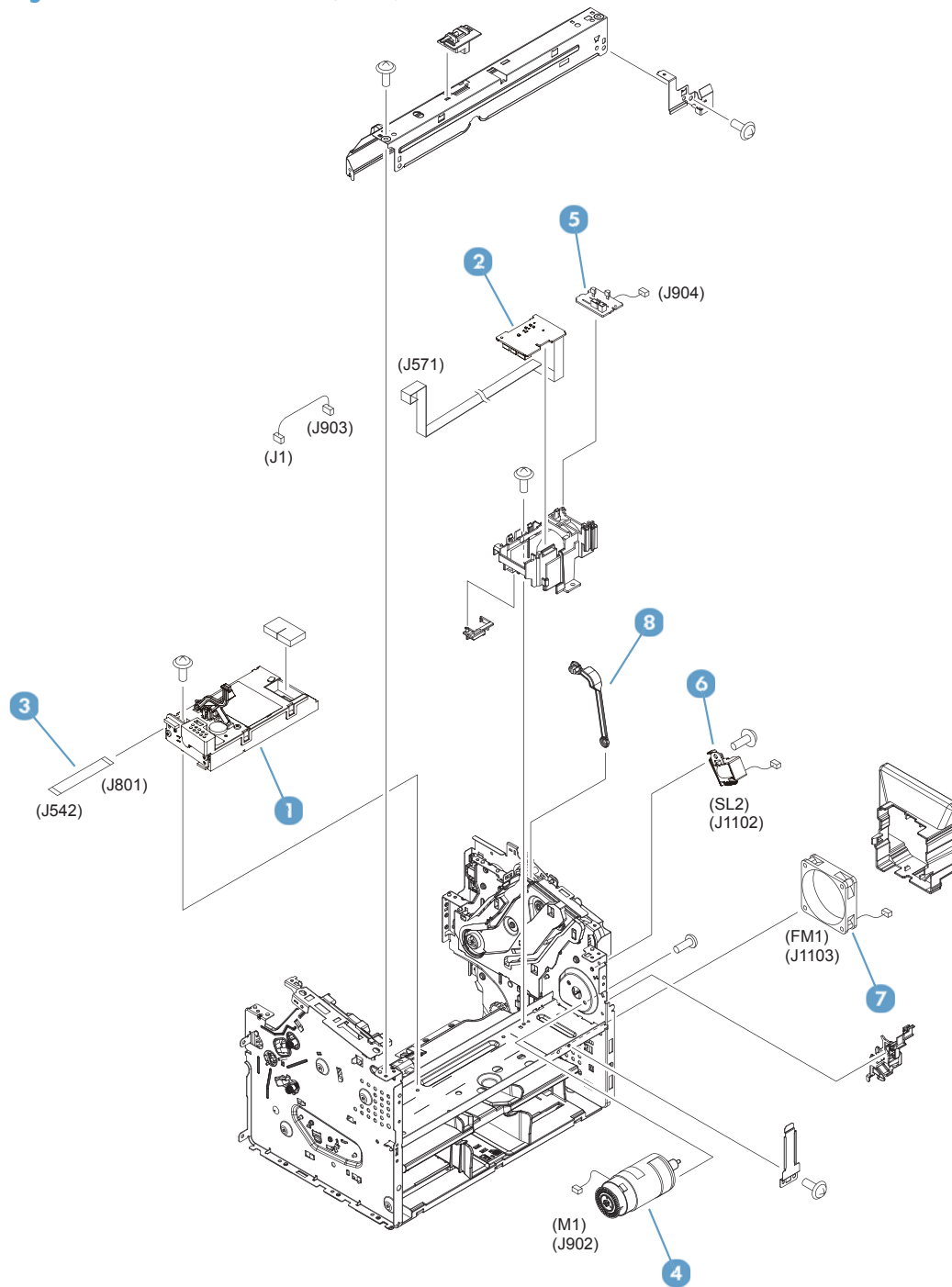

Table 3-9 Internal assemblies (3 of 3)

Ref	Description	Part number	Qty
1	Laser scanner assembly	RM2-0426-000	1
2	Motor PCB assembly	RM2-7634-000	1
3	Cable, flat	RK2-6691-000	1
4	Motor, DC24V	RM2-0418-000	1
5	Duplexing PCB assembly	RM2-7608-000	1
6	Solenoid	RK2-0420-000	1
7	Fan	RK2-6694-000	1
8	Link, cartridge door, CH IN	RC2-9514-000	1

Scanner and document feeder (ADF)

Scanner and document feeder (ADF) main assemblies

Figure 3-5 Scanner and document feeder (ADF) main assemblies

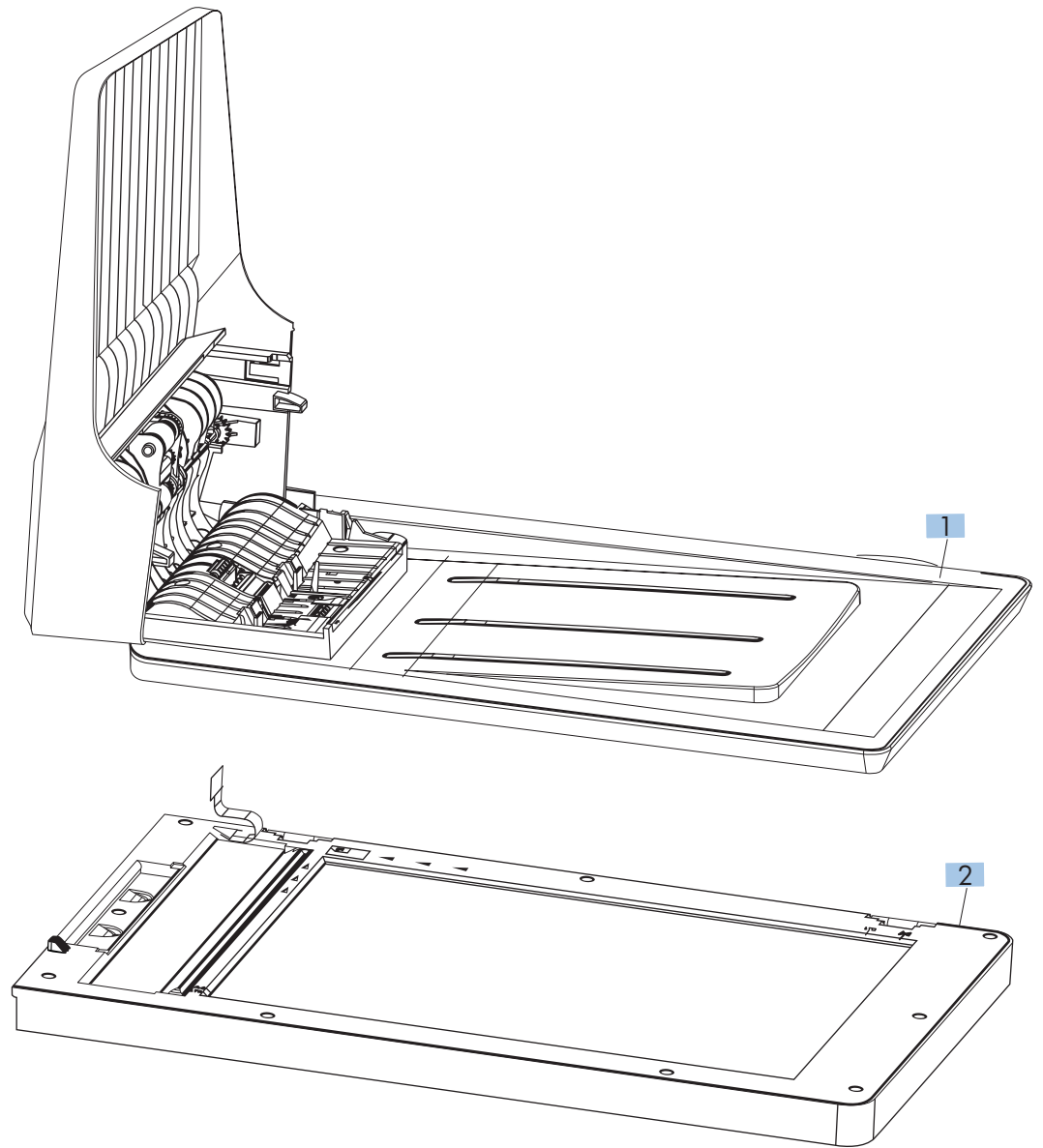

Table 3-10 Scanner and document feeder (ADF) main assemblies

Ref	Description	Part number	Qty
NA	Assembly, scanner/ADF (complete)	CF484-60103	1
1	Assembly, Auto Document Feeder	CF484-60116	1
2	1200PPI scanner assembly	CF484-60110	1

Document feeder internal components

Figure 3-6 Document feeder internal components

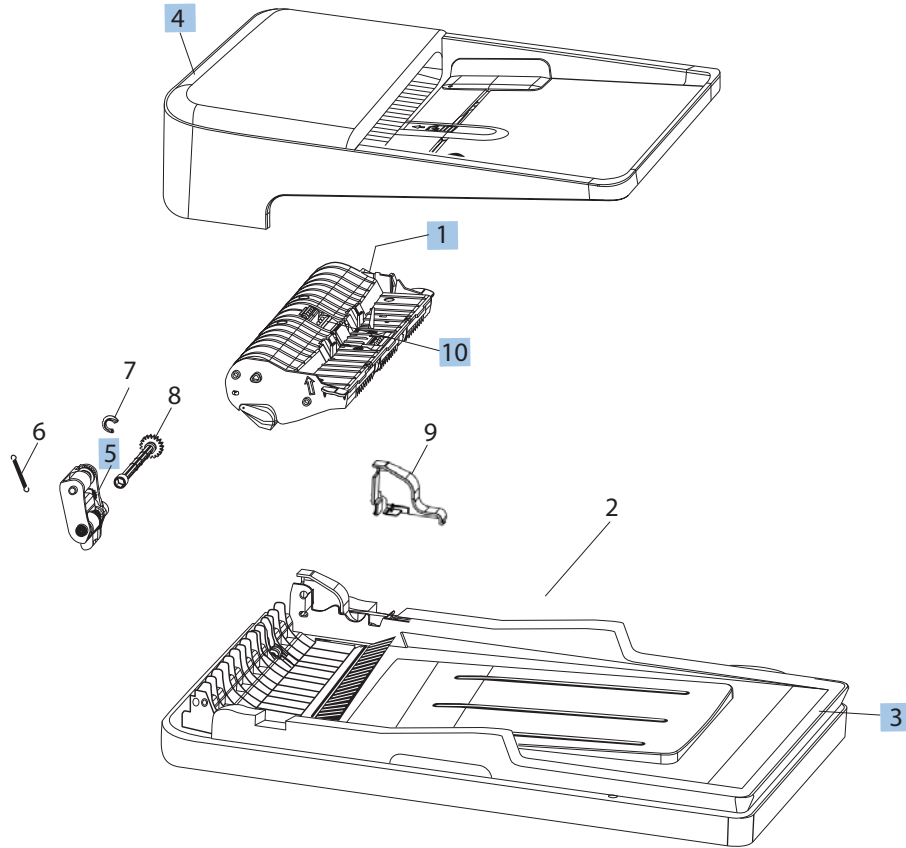

Table 3-11 Document feeder internal components

Ref	Description	Part number	Qty
1	Assembly, ADF core	CF484-60118	1
3	Assembly, ADF base	CF484-60120	1
4	Assembly, ADF cover and adjuster	CF484-60127	1
5	Assembly, pick arm	CF144-60142	1
10	Assembly, separator pad	Q7400-60005	1

Scanner assembly internal components

Scanner assembly internal components (1 of 2)

Figure 3-7 Scanner assembly internal components (1 of 2)

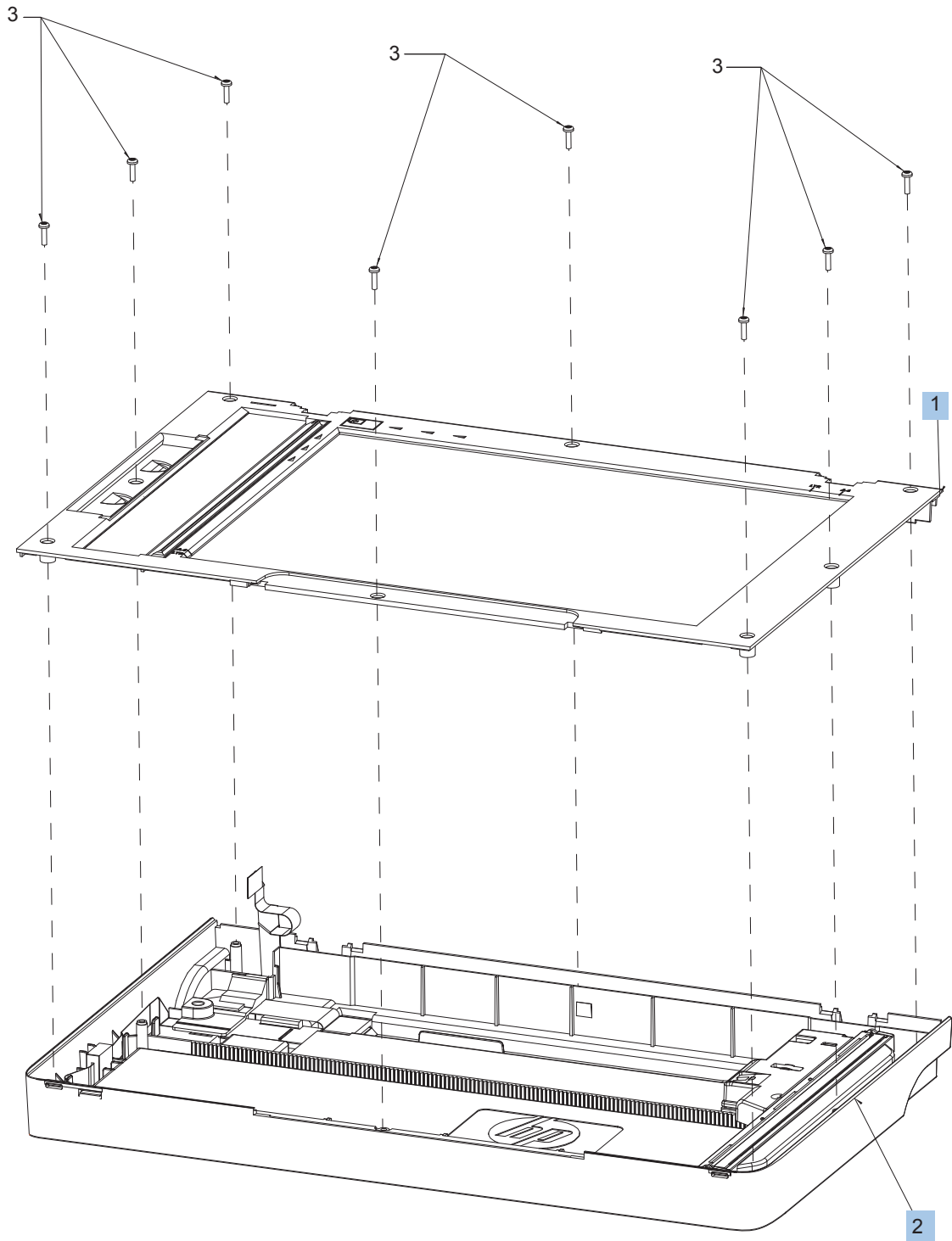

Table 3-12 Scanner assembly internal components (1 of 2)

Ref	Description	Part number	Qty
1	Assembly, scan bezel ¹	CF484-60111	1
2	Assembly, scanner base ¹	CF484-60112	1

¹ Part must be replaced in a dust-free chamber.

Scanner assembly internal components (2 of 2)

Figure 3-8 Scanner assembly internal components (2 of 2)

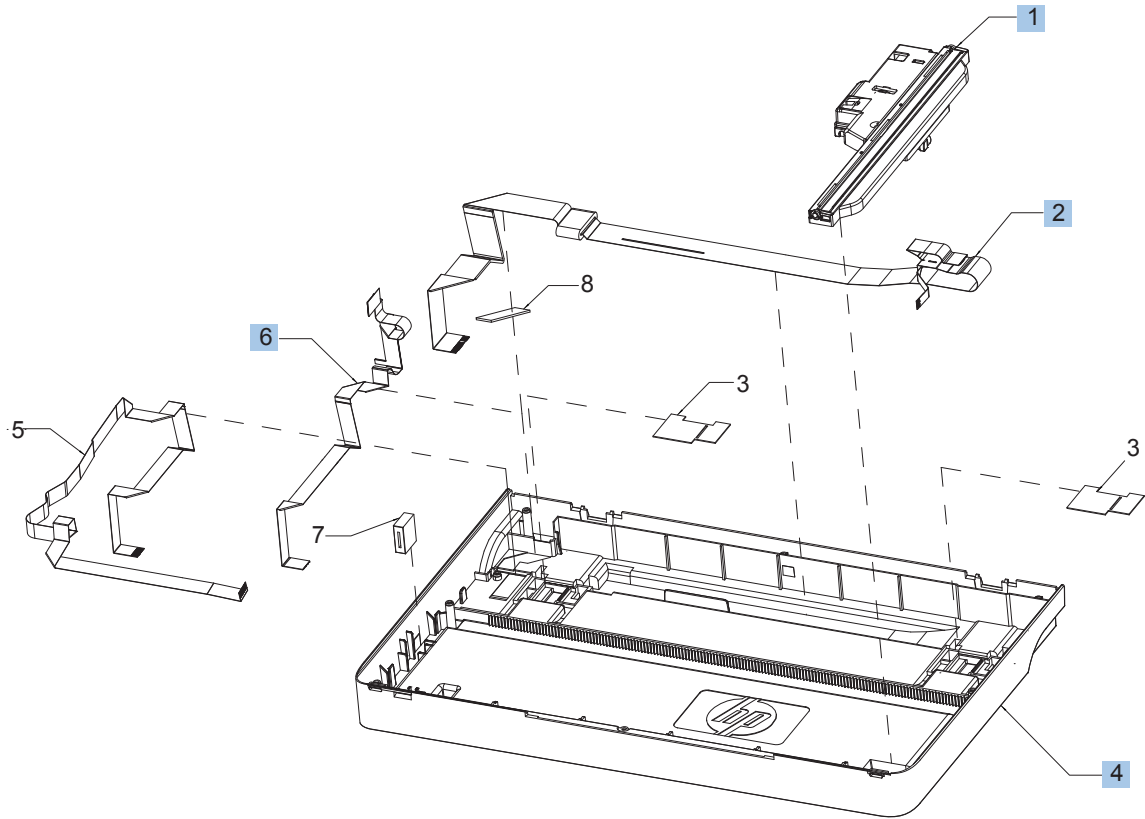

Table 3-13 Scanner assembly internal components (2 of 2)

Ref	Description	Part number	Qty
1	Assembly, scan drive system ¹	CF484-60113	1
2	Assembly, scan module/motor cable ¹	CF484-60105	1
4	Scanner base ¹	CF484-40001	1
6	Assembly, ADF cable ¹	CF484-60104	1

¹ Part must be replaced in a dust-free chamber.

Alphabetical parts list

Table 3-14 Alphabetical parts list

Description	Part number	Table and page
1200PPI scanner assembly	CF484-60110	Scanner and document feeder (ADF) main assemblies on page 153
Assembly, ADF base	CF484-60120	Document feeder internal components on page 155
Assembly, ADF cable ¹¹	CF484-60104	Scanner assembly internal components (2 of 2) on page 159
Assembly, ADF core	CF484-60118	Document feeder internal components on page 155
Assembly, ADF cover and adjuster	CF484-60127	Document feeder internal components on page 155
Assembly, Auto Document Feeder	CF484-60116	Scanner and document feeder (ADF) main assemblies on page 153
Assembly, pick arm	CF144-60142	Document feeder internal components on page 155
Assembly, scan bezel ¹¹	CF484-60111	Scanner assembly internal components (1 of 2) on page 157
Assembly, scan drive system ¹¹	CF484-60113	Scanner assembly internal components (2 of 2) on page 159
Assembly, scan module/motor cable ¹¹	CF484-60105	Scanner assembly internal components (2 of 2) on page 159
Assembly, scanner base ¹¹	CF484-60112	Scanner assembly internal components (1 of 2) on page 157
Assembly, scanner/ADF (complete)	CF484-60103	Scanner and document feeder (ADF) main assemblies on page 153
Assembly, separator pad	Q7400-60005	Document feeder internal components on page 155
Cable, flat	RK2-6691-000	Internal assemblies (3 of 3) on page 151
Cartridge door assembly	RM1-9890-000	External panels and covers on page 145
Cover, dust	RC3-3902-000	External panels and covers on page 145
Cover, front	RL1-3802-000	External panels and covers on page 145
Cover, left	RL1-3803-000	External panels and covers on page 145
Cover, right	RC3-4792-000	External panels and covers on page 145

Table 3-14 Alphabetical parts list (continued)

Description	Part number	Table and page
Cover, top	RC3-4790-000	External panels and covers on page 145
Delivery sensor PCB assembly	RM2-7629-000	Internal assemblies (1 of 3) on page 147
Duplexing door assembly	RM1-9654-000	External panels and covers on page 145
Duplexing frame assembly	RM1-9655-000	Internal assemblies (2 of 3) on page 149
Duplexing PCB assembly	RM2-7608-000	Internal assemblies (3 of 3) on page 151
Engine control PCB assembly, 110-127V	RM2-7632-000	Internal assemblies (1 of 3) on page 147
Engine control PCB assembly, 220-240V	RM2-7633-000	Internal assemblies (1 of 3) on page 147
Engine control PCB assembly, 220-240V, CH IN	RM2-8080-000	Internal assemblies (1 of 3) on page 147
Fan	RK2-6694-000	Internal assemblies (3 of 3) on page 151
Fixing assembly, 110-127V	RM1-9891-000	Internal assemblies (1 of 3) on page 147
Fixing assembly, 220-240V	RM1-9892-000	Internal assemblies (1 of 3) on page 147
Fixing film assembly, 110-127V	RM1-9656-000	Internal assemblies (1 of 3) on page 147
Fixing film assembly, 220-240V	RM1-9657-000	Internal assemblies (1 of 3) on page 147
Laser scanner assembly	RM2-0426-000	Internal assemblies (3 of 3) on page 151
Link, cartridge door	RC2-9527-000	Internal assemblies (1 of 3) on page 147
Link, cartridge door, CH IN	RC2-9514-000	Internal assemblies (3 of 3) on page 151
Link, pressure release	RC2-9531-000	Internal assemblies (1 of 3) on page 147
Motor PCB assembly	RM2-7634-000	Internal assemblies (3 of 3) on page 151
Motor, DC24V	RM2-0418-000	Internal assemblies (3 of 3) on page 151
Paper delivery tray assembly	RM1-9649-000	External panels and covers on page 145
Paper pick-up assembly	RM2-6524-000	Internal assemblies (2 of 3) on page 149

Table 3-14 Alphabetical parts list (continued)

Description	Part number	Table and page
Paper pick-up sensor PCB assembly	RM2-7635-000	Internal assemblies (2 of 3) on page 149
Paper pick-up tray assembly	RM1-9677-000	External panels and covers on page 145
Roller, pickup	RL1-3642-000	Internal assemblies (2 of 3) on page 149
Roller, transfer	RM1-4023-000	Internal assemblies (2 of 3) on page 149
Scanner base ¹	CF484-40001	Scanner assembly internal components (2 of 2) on page 159
Separation pad assembly	RM1-4227-000	Internal assemblies (2 of 3) on page 149
Solenoid	RK2-0420-000	Internal assemblies (3 of 3) on page 151

Numerical parts list

Table 3-15 Numerical parts list

Part number	Description	Table and page
CF144-60142	Assembly, pick arm	Document feeder internal components on page 155
CF484-40001	Scanner base ¹¹	Scanner assembly internal components (2 of 2) on page 159
CF484-60103	Assembly, scanner/ADF (complete)	Scanner and document feeder (ADF) main assemblies on page 153
CF484-60104	Assembly, ADF cable ¹¹	Scanner assembly internal components (2 of 2) on page 159
CF484-60105	Assembly, scan module/motor cable ¹¹	Scanner assembly internal components (2 of 2) on page 159
CF484-60110	1200PPI scanner assembly	Scanner and document feeder (ADF) main assemblies on page 153
CF484-60111	Assembly, scan bezel ¹¹	Scanner assembly internal components (1 of 2) on page 157
CF484-60112	Assembly, scanner base ¹¹	Scanner assembly internal components (1 of 2) on page 157
CF484-60113	Assembly, scan drive system ¹¹	Scanner assembly internal components (2 of 2) on page 159
CF484-60116	Assembly, Auto Document Feeder	Scanner and document feeder (ADF) main assemblies on page 153
CF484-60118	Assembly, ADF core	Document feeder internal components on page 155
CF484-60120	Assembly, ADF base	Document feeder internal components on page 155
CF484-60127	Assembly, ADF cover and adjuster	Document feeder internal components on page 155
Q7400-60005	Assembly, separator pad	Document feeder internal components on page 155
RC2-9514-000	Link, cartridge door, CH IN	Internal assemblies (3 of 3) on page 151
RC2-9527-000	Link, cartridge door	Internal assemblies (1 of 3) on page 147
RC2-9531-000	Link, pressure release	Internal assemblies (1 of 3) on page 147
RC3-3902-000	Cover, dust	External panels and covers on page 145
RC3-4790-000	Cover, top	External panels and covers on page 145

Table 3-15 Numerical parts list (continued)

Part number	Description	Table and page
RC3-4792-000	Cover, right	External panels and covers on page 145
RK2-0420-000	Solenoid	Internal assemblies (3 of 3) on page 151
RK2-6691-000	Cable, flat	Internal assemblies (3 of 3) on page 151
RK2-6694-000	Fan	Internal assemblies (3 of 3) on page 151
RL1-3642-000	Roller, pickup	Internal assemblies (2 of 3) on page 149
RL1-3802-000	Cover, front	External panels and covers on page 145
RL1-3803-000	Cover, left	External panels and covers on page 145
RM1-4023-000	Roller, transfer	Internal assemblies (2 of 3) on page 149
RM1-4227-000	Separation pad assembly	Internal assemblies (2 of 3) on page 149
RM1-9649-000	Paper delivery tray assembly	External panels and covers on page 145
RM1-9654-000	Duplexing door assembly	External panels and covers on page 145
RM1-9655-000	Duplexing frame assembly	Internal assemblies (2 of 3) on page 149
RM1-9656-000	Fixing film assembly, 110-127V	Internal assemblies (1 of 3) on page 147
RM1-9657-000	Fixing film assembly, 220-240V	Internal assemblies (1 of 3) on page 147
RM1-9677-000	Paper pick-up tray assembly	External panels and covers on page 145
RM1-9890-000	Cartridge door assembly	External panels and covers on page 145
RM1-9891-000	Fixing assembly, 110-127V	Internal assemblies (1 of 3) on page 147
RM1-9892-000	Fixing assembly, 220-240V	Internal assemblies (1 of 3) on page 147
RM2-0418-000	Motor, DC24V	Internal assemblies (3 of 3) on page 151
RM2-0426-000	Laser scanner assembly	Internal assemblies (3 of 3) on page 151
RM2-6524-000	Paper pick-up assembly	Internal assemblies (2 of 3) on page 149

Table 3-15 Numerical parts list (continued)

Part number	Description	Table and page
RM2-7608-000	Duplexing PCB assembly	Internal assemblies (3 of 3) on page 151
RM2-7629-000	Delivery sensor PCB assembly	Internal assemblies (1 of 3) on page 147
RM2-7632-000	Engine control PCB assembly, 110-127V	Internal assemblies (1 of 3) on page 147
RM2-7633-000	Engine control PCB assembly, 220-240V	Internal assemblies (1 of 3) on page 147
RM2-7634-000	Motor PCB assembly	Internal assemblies (3 of 3) on page 151
RM2-7635-000	Paper pick-up sensor PCB assembly	Internal assemblies (2 of 3) on page 149
RM2-8080-000	Engine control PCB assembly, 220-240V, CH IN	Internal assemblies (1 of 3) on page 147

Index

A

- accessories
 - ordering 118, 140
- after-service checklist 5

C

- cartridge
 - ordering 118, 140
 - part number, M201 and M202 118
 - part number, M225 and M226 140
- cartridge door, removing
 - M201 and M202 duplex products 29
 - M201 and M202 simplex products 23
 - M225 and M226 48
- cautions iii
- checklists
 - after-service 5
 - preservice 5
- controller PCA, engine
 - reinstalling 93
 - removing 88
- conventions, document iii
- copy-quality test 5
- customer self repair parts
 - part numbers, M201 and M202 119
- customer self-repair (CSR)
 - components 8
 - pickup roller 8
 - separation pad 9
- customer-replaceable units (CRU)
 - part numbers, M201 and M202 119

D

- document conventions iii
- drive belt, main motor
 - removing 82
- duplex door, removing
 - M201 and M202 duplex products 20
 - M225 and M226 46
- duplex frame, removing
 - M201 and M202 duplex products 21
 - M225 and M226 47
- duplex-connector PCA, duplex products
 - removing 102
- Duplex-reverse solenoid, duplex products
 - removing 96
- dust cover
 - removing 11

E

- electrostatic discharge (ESD) 2
- engine controller PCA
 - reinstalling 93
 - removing 88
- ESD (electrostatic discharge) 2
- External panels, covers, and doors:
 - M201 and M202
 - removing and replacing 10

F

- formatter PCA
 - removing 54
- front cover, removing
 - M201 and M202 15
 - M225 and M226 38

fuser

- reinstalling 61
- removing 56
- fuser film assembly
 - reinstalling 66
 - removing 63

I

- input tray
 - removing 11

L

- laser/scanner assembly
 - reinstalling 69
 - removing 66
- left cover, removing
 - M201 and M202 duplex products 12
 - M201 and M202 simplex products 13
 - M225 and M226 37

M

- main fan, duplex products
 - reinstalling 101
 - removing 99
- main motor
 - removing 78
- main motor drive belt
 - removing 82

N

- notes iii

O

- ordering
 - print cartridge 118, 140
 - product documents 118, 140
 - supplies and accessories 118, 140

- whole-unit replacement, M201 and M202 119
- whole-unit replacement, M225 and M226 141
- output tray
 - removing 11
- P**
- part number
 - external panels and covers, M201 and M202 duplex products 122
 - external panels and covers, M201 and M202 simplex products 124
 - external panels and covers, M225 and M226 144
 - internal assemblies, M201 and M202 126, 128, 130
 - internal assemblies, M225 and M226 146, 148, 150
 - print cartridge, M225 and M226 140
 - whole-unit replacement, M201 and M202 119
 - whole-unit replacement, M225 and M226 141
- part number, M201 and M202
 - print cartridge 118
- parts diagram
 - external panels and covers, M201 and M202 duplex products 122
 - external panels and covers, M201 and M202 simplex products 124
 - external panels and covers, M225 and M226 144
 - internal assemblies, M201 and M202 126, 128, 130
 - internal assemblies, M225 and M226 146, 148, 150
- parts removal order
 - ADF 7
 - all models 6
 - M201, M202 6
 - M225, M226 6, 7
 - product base 6
 - scanner 7

- pickup assembly
 - reinstalling 75
 - removing 70
- pickup solenoid
 - removing 84
- pliers, required 2
- post-service tests 5
- preservice checklist 5
- print cartridge
 - ordering 118, 140
 - part number 118
 - part number, M225 and M226 140
- print quality
 - test 5

- R**
- rear cover, removing
 - M201 and M202 simplex products 22
- removing parts
 - cautions for 2
 - checklists 5
 - tools, required 2
- replacing
 - parts 2
- right cover, removing
 - M201 and M202 duplex products 16
 - M201 and M202 simplex products 18
 - M225 and M226 40

- S**
- scanner assembly
 - removing 43
- scanner hinges
 - removing 45
- screwdrivers, required 2
- screws
 - replacing 2
- service
 - tools, required 2
- static precautions 2
- supplies
 - ordering 118, 140

- T**
- tests
 - copy-quality 5

- post-service 5
- print-quality 5
- tips iii
- tools, required 2
- top cover cap, removing
 - M201 and M202 duplex products 14
 - M225 and M226 50
- Top cover, removing
 - M201 and M202 33
- top cover, removing
 - M201 and M202 simplex products 26
 - M225 and M226 52
- transfer roller
 - removing 54

- W**
- warnings iii

