







ARDF DF3090
Machine Code: D779
Field Service Manual
Ver 1.0

Initial Release: Nov, 2016
Copyright (c) 2016 Ricoh Co.,Ltd.

Symbols, Abbreviations

Symbols, Abbreviations

This manual uses several symbols and abbreviations. The meaning of those symbols and abbreviations are as follows:

| Symbol | What it means |
|---|---------------------|
|  | Clip ring |
|  | Screw |
|  | Connector |
|  | Clamp |
|  | E-ring |
|  | Flat Flexible Cable |
|  | Timing Belt |
| SEF | Short Edge Feed |
| LEF | Long Edge Feed |
| K | Black |
| C | Cyan |
| M | Magenta |
| Y | Yellow |
| B/W, BW | Black and White |
| FC | Full color |

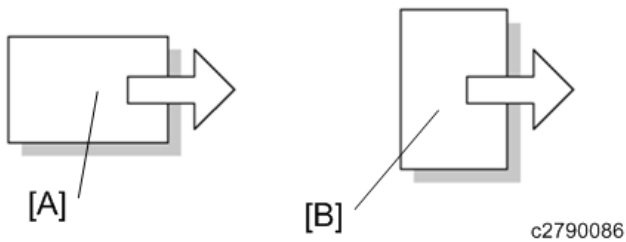

[A] Short Edge Feed (SEF)

[B] Long Edge Feed (LEF)

Table of Contents

| | |
|---|----|
| 1. Replacement and Adjustment..... | 2 |
| Document Feeder..... | 2 |
| Original Feed Unit..... | 2 |
| Exterior Covers and Original Tray..... | 3 |
| Rear Cover..... | 3 |
| Front Cover and Original Tray..... | 3 |
| Hinge..... | 4 |
| Sensors and Switch..... | 12 |
| Original Length Sensors and Original Sensor..... | 12 |
| Original Set Sensor..... | 12 |
| Original Width Sensors and Skew Correction Sensor..... | 14 |
| Original Exit Sensor..... | 15 |
| Registration Sensor..... | 16 |
| DF Position Sensor..... | 16 |
| Left Cover Switch..... | 17 |
| Motors, Solenoids, and Clutches..... | 18 |
| Feed Motor..... | 18 |
| Transport Motor..... | 19 |
| Stamp Solenoid..... | 20 |
| Pick-up Solenoid..... | 21 |
| Inverter Solenoid..... | 22 |
| Feed Clutch..... | 22 |
| Belt and Rollers..... | 24 |
| Feed Belt..... | 24 |
| Pick-Up Roller..... | 25 |
| Separation Roller..... | 25 |
| Board..... | 26 |
| ARDF Drive Board..... | 26 |
| 2. Detailed Descriptions..... | 27 |
| ARDF DF3090 (D779)..... | 27 |
| Parts Layout..... | 27 |
| Mechanism..... | 28 |
| SP6-901-002 (Setting to give priority to stackability)..... | 32 |

1. Replacement and Adjustment

Document Feeder

Original Feed Unit

- 1.** Open the left cover.
- 2.** Original feed unit [A]



d578r502

Note

- Pull the original feed unit forward to release the back side of the shaft.

Exterior Covers and Original Tray

Rear Cover

1. Open the left cover [A].
2. Open the original tray [B].
3. Rear cover [C] (⚙️×1, hook×5)

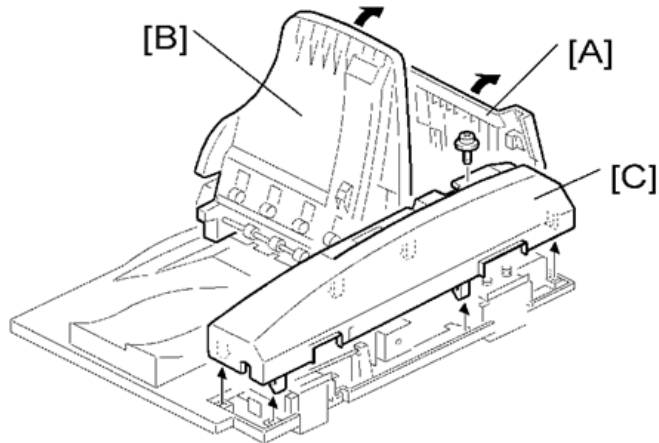

Front Cover and Original Tray

1. Open the left cover.
2. Rear cover ([Rear Cover](#))
3. Front cover [A] (⚙️×1)

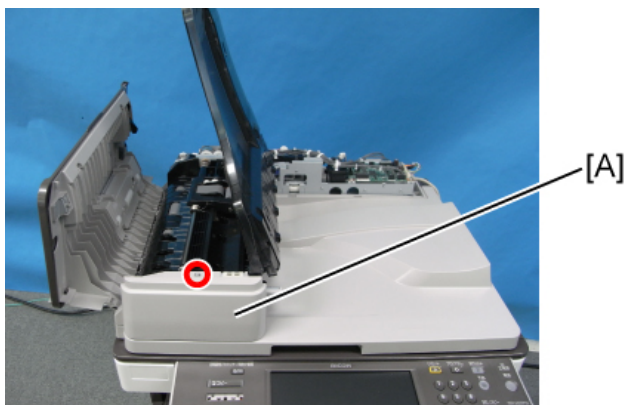

d578r500

Note

- Keep the original tray open when removing the front cover.

1.Replacement and Adjustment

4. Original tray [A] (🔧×1, 📦×1, 🛠️×1)

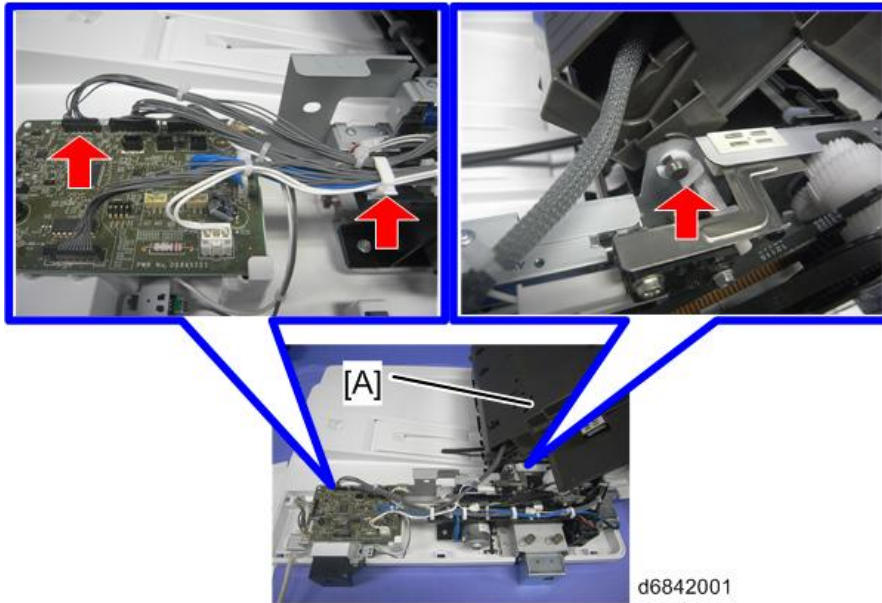

Hinge

1. Remove the ARDF from the main machine.
2. Place the ARDF on a flat surface, and place it so that the hinge does not hit against that surface.

Note

- Be careful not to scratch the scanning area [A] (guide plate and mylar).
- Be careful not to hook the actuator [B]. (It is a movable actuator; it is stored in the ARDF when you push it and it comes back because of a spring.)

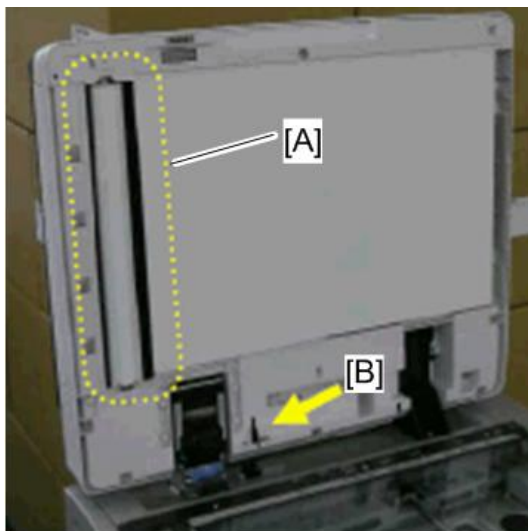

3. Remove the rear cover of the ARDF.



d146z9001

4. Remove the following parts.

- Clamp
- Harness
- Connectors [A] (🔌 ×3)
- Screw [B] (🔩 ×1)

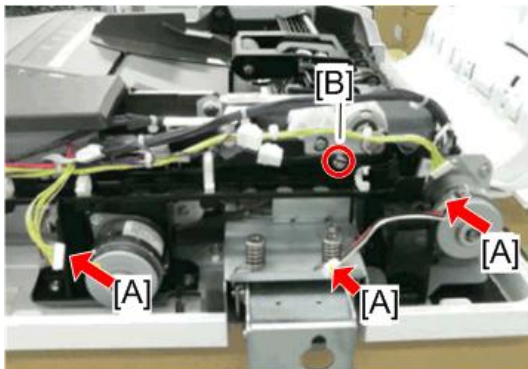

d146z9002

5. Remove the screws [A] and spring [B] of the feed motor bracket, and remove the feed motor unit. (🔩 ×2, spring ×1)

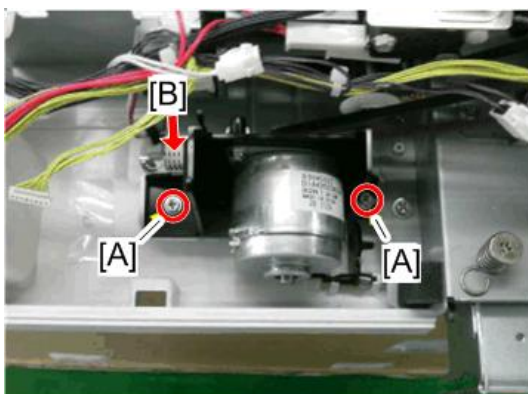

d146z9003

1.Replacement and Adjustment

- 6.** Remove the resin ring [A] and flanges, and remove the timing belt. Then, remove the reverse torque limiter [B] from the shaft.

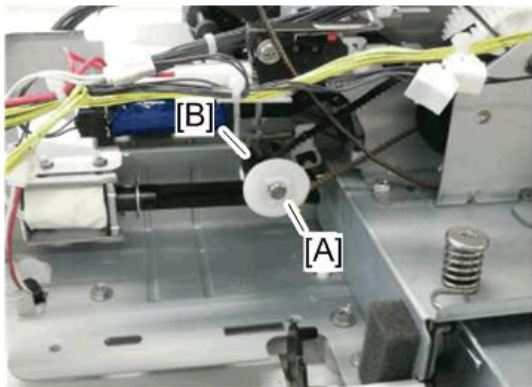

d146z9004

- 7.** Disconnect the link [A] of the junction gate, and remove the E-ring [B] of the fixing shaft. (Ⓒ×1)

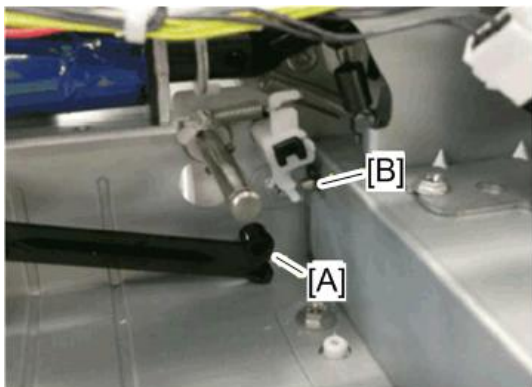

d146z9005

- 8.** Loosen the screw [A] of the belt tension unit and remove the spring [B]. (Ⓒ×1, spring ×1)

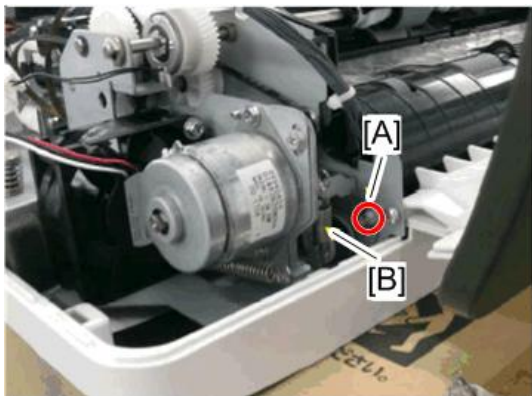

d146z9006

- 9.** Remove the screws [A] of the motor bracket, and remove the transport motor unit. (🔩×2)

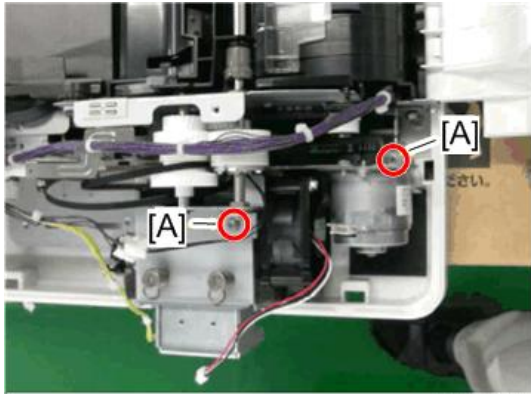

d146z9007

- 10.** Remove the belt tension unit and screw [A], and pull out the hinge fixing shaft [B] (do not remove the E-ring on the fixing shaft side).

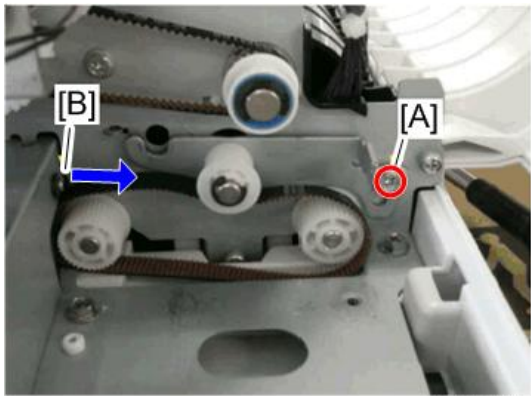

d146z9008

- 11.** Remove the step screws and springs [A] of the hinge, and remove the hinge [B]. (🔩×2, spring ×2)
Note: Grease is applied to the step screws.

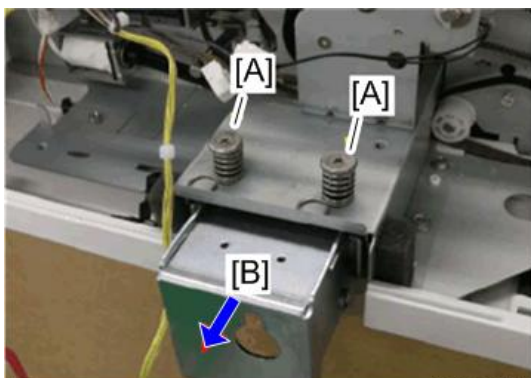

d146z9009

1.Replacement and Adjustment

- 12.** Insert the left hinge with a damper [A] and insert the hinge fixing shaft [B].

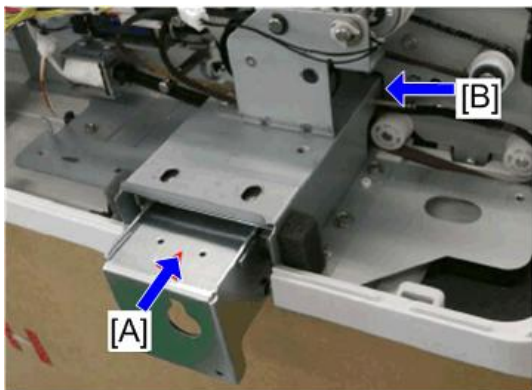

d146z9010

- 13.** Fix the hinge fixing shaft with an E-ring, and insert the link [B] of the junction gate. (C×1)
After inserting the link, pull it slightly to check that it does not fall out.

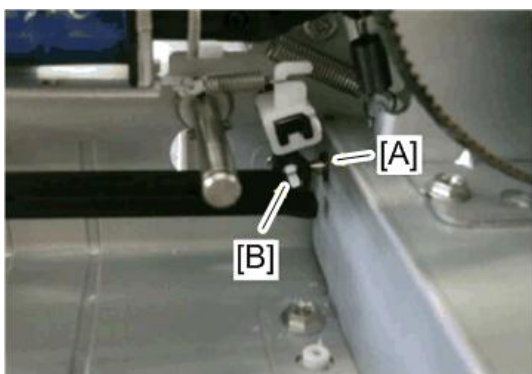

d146z9011

- 14.** Attach the step screws and springs of the hinge. After attaching them, push the screw top to check that the screws are pushed down.

When the screws do not move, the step screws may be fixed with the plate stay. Loosen and fix the screws again.

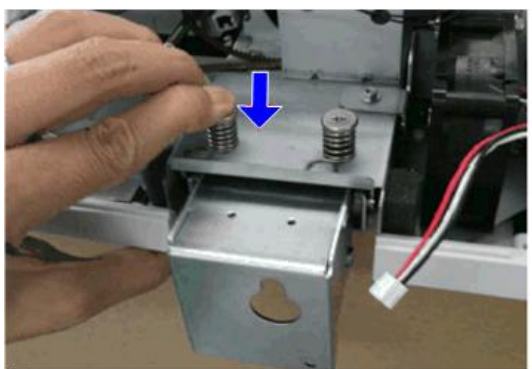

d146z9012

- 15.** Attach the reverse torque limiter [A].
Put the torque limiter on the shaft, hook the timing belt, attach the flange, and fix it with the resin ring.

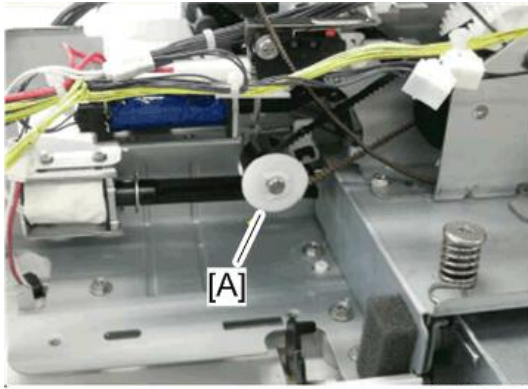

d146z9013

- 16.** Attach the transport motor unit. (⚙️×2)

Attach the bracket to the plate, hook the timing belt onto the motor pulley, and hook the spring. Do not fix the screws [A] completely, so that the motor unit can move left and right.

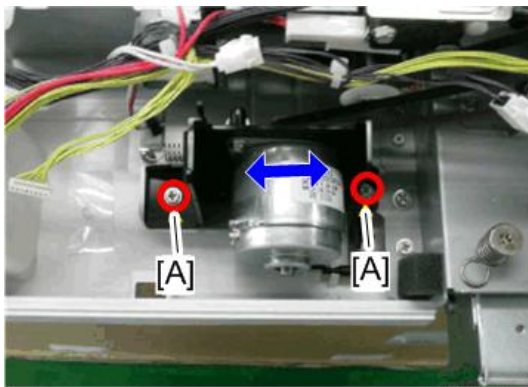

d146z9014

- 17.** Rotate the white gear [A] by hand to warm up the timing belt. (⚙️×2)

Fix the screws [B] of the feed motor bracket completely, which were attached in step 16. (The picture has been taken after attaching the harness guide.)

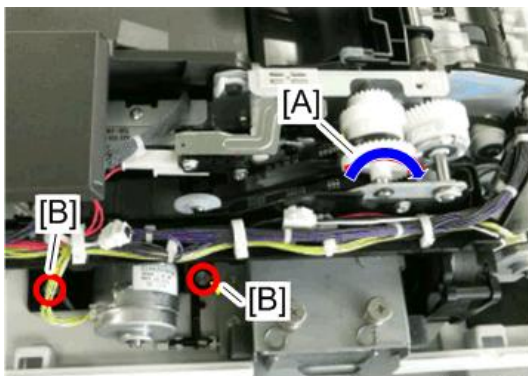

d146z9015

- 18.** Attach the belt tension unit. Do not fix the screw [A] completely. Move the cutout of the belt tension unit to

1.Replacement and Adjustment

fit the hole [B] in the rear plate. (⊙×1)

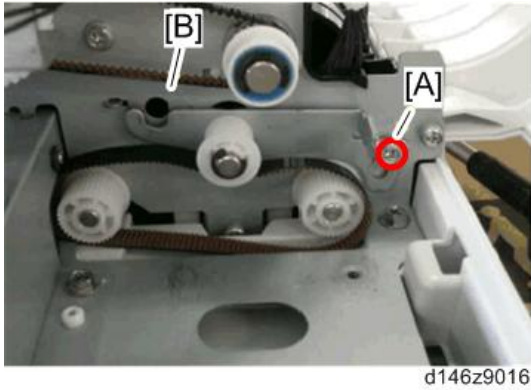

- 19.** Hook the belt [A] onto the pulley of the transport motor unit, and insert the shaft into the hole in the rear plate, shown in step 18.

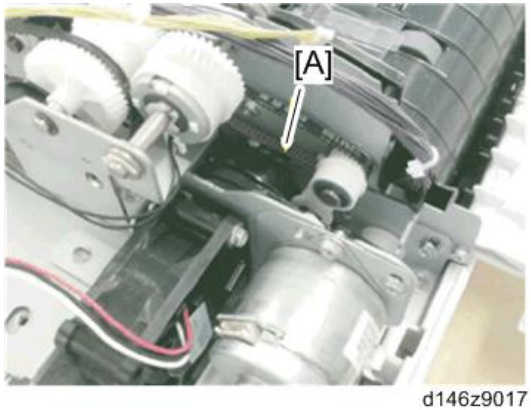

- 20.** Fix the two screws [A] of the transport motor unit, and hook the spring [B] of the belt tension unit. Do not fix the screw [C] of the belt tension completely. (⊙×3, spring×1)

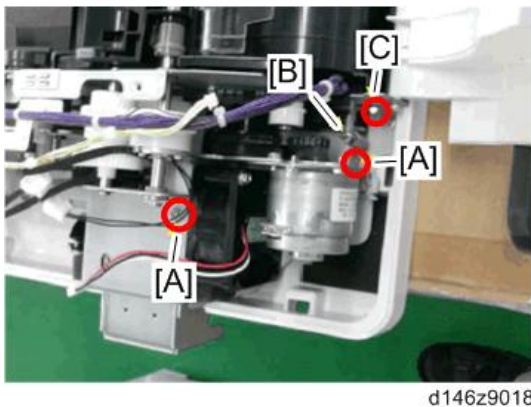

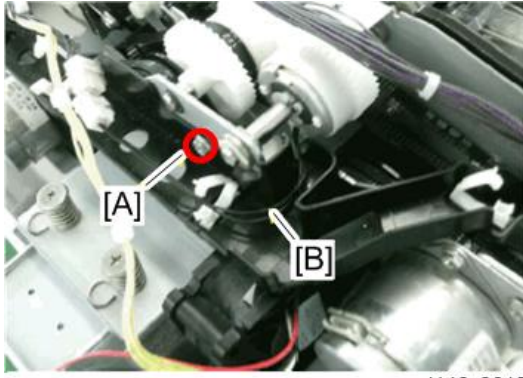

- 21.** Attach the harness guide and fix it with the screw [A]. (⊙×1)
The harness [B] of the clutch should be passed as shown below.

1.Replacement and Adjustment



d146z9019

22. Insert the connector of the motor and the connector of the cooling fan, and fix the harness with the clamp.

( ×2,  ×1)

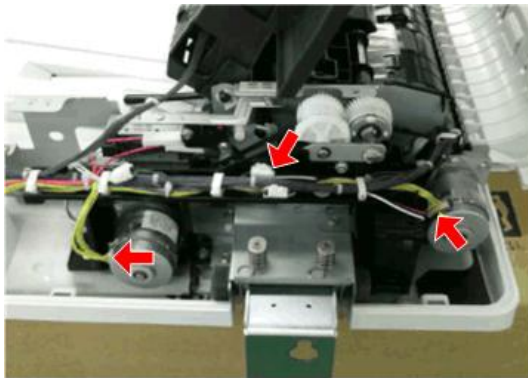

d146z9020

Sensors and Switch

Original Length Sensors and Original Sensor

1. Original Tray (Front Cover and Original Tray)
2. Tray cover [A] (🔩×3)



d6842009

3. Remove the following items:
 - Original sensor [A] (🔧×1)
 - Original length sensors [B] (🔧×1 each)

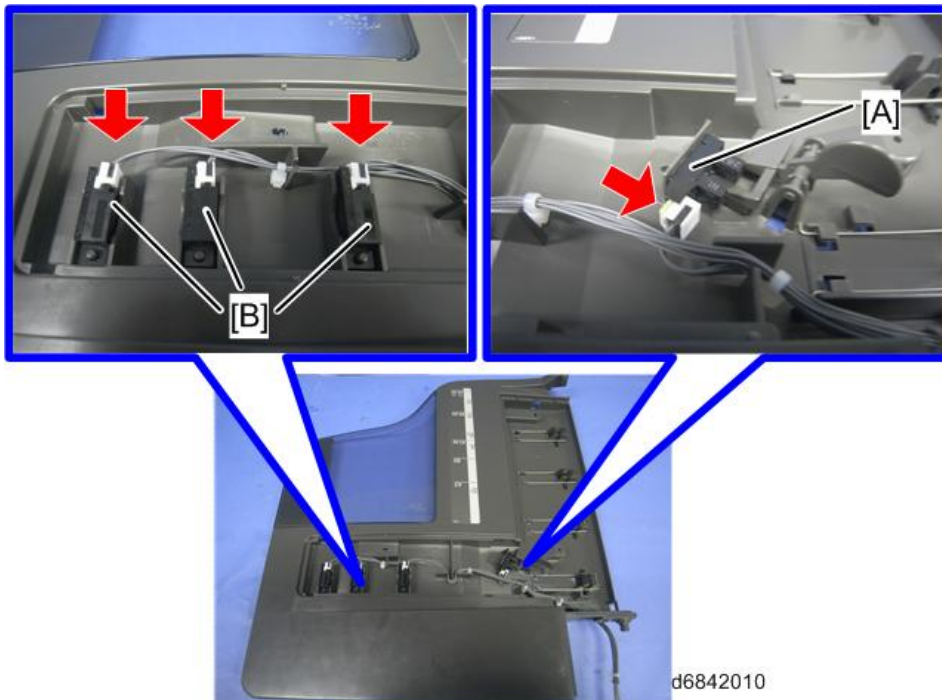

d6842010

Original Set Sensor

1. Original feed unit (Original Feed Unit)
2. Original tray (Front Cover and Original Tray)

- 3.** Original feed-in guide plate [A] (hook ×3)

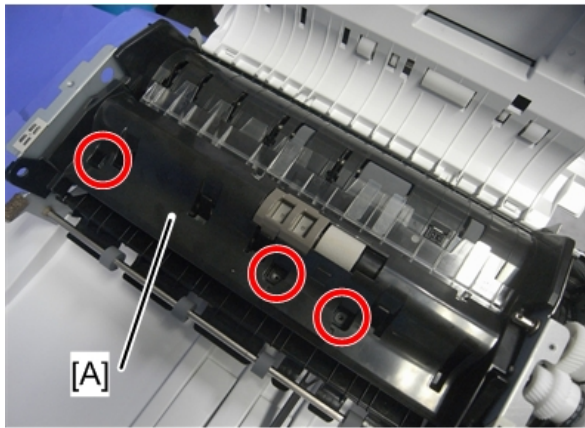

d6842012

- 4.** Feed guide [A]

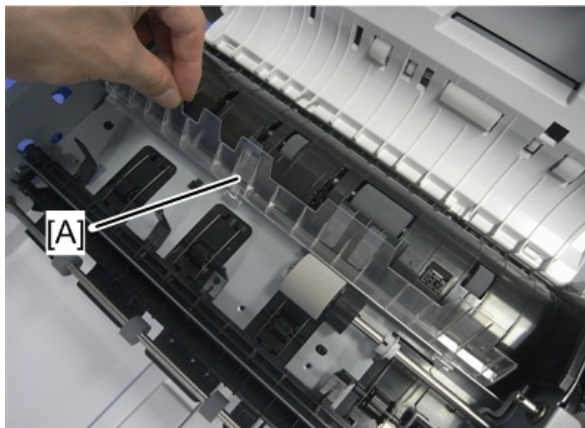

d6842013

- 5.** Original turn guide plate [A] (hook ×2)



d6842014

1.Replacement and Adjustment

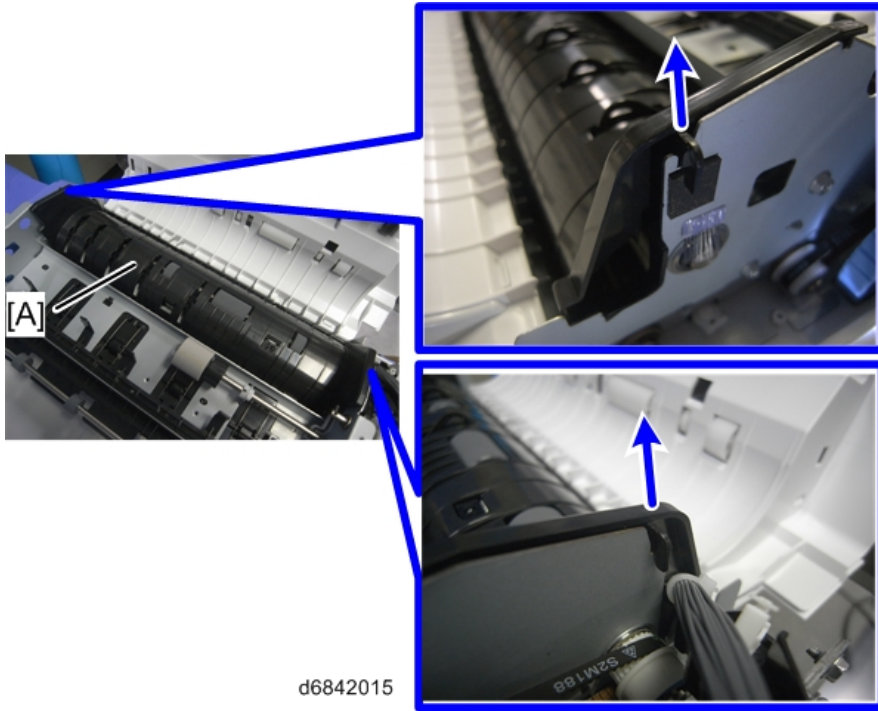

- 6.** Original set sensor bracket [A] (hook ×2)

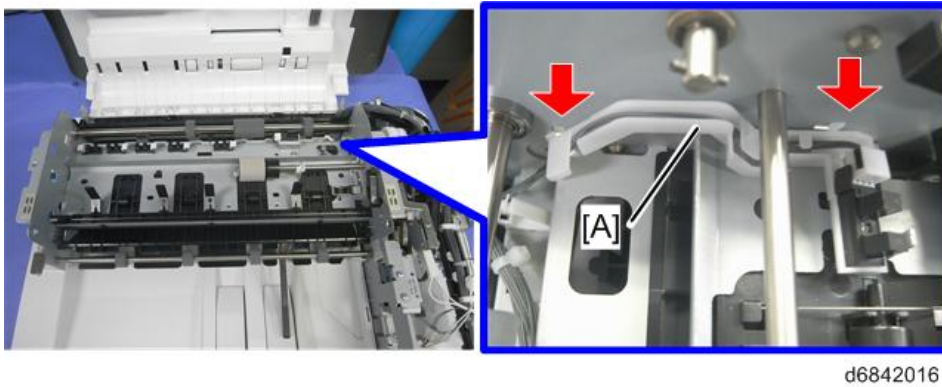

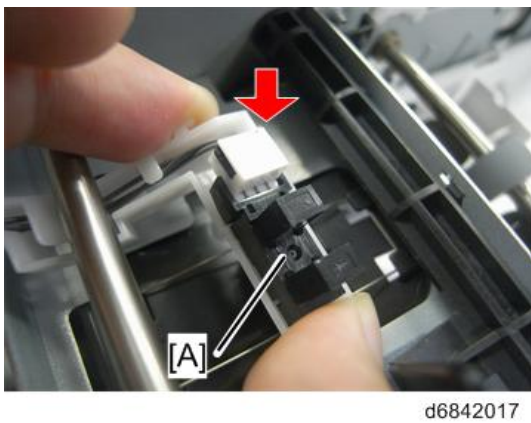

- 7.** Original set sensor [A] (📦 ×1)



Original Width Sensors and Skew Correction Sensor

- 1.** Original turn guide plate (Original Set Sensor)

2. Original width sensors [A] ( ×1 each) and skew correction sensor [B] with bracket ( ×1,  ×1)

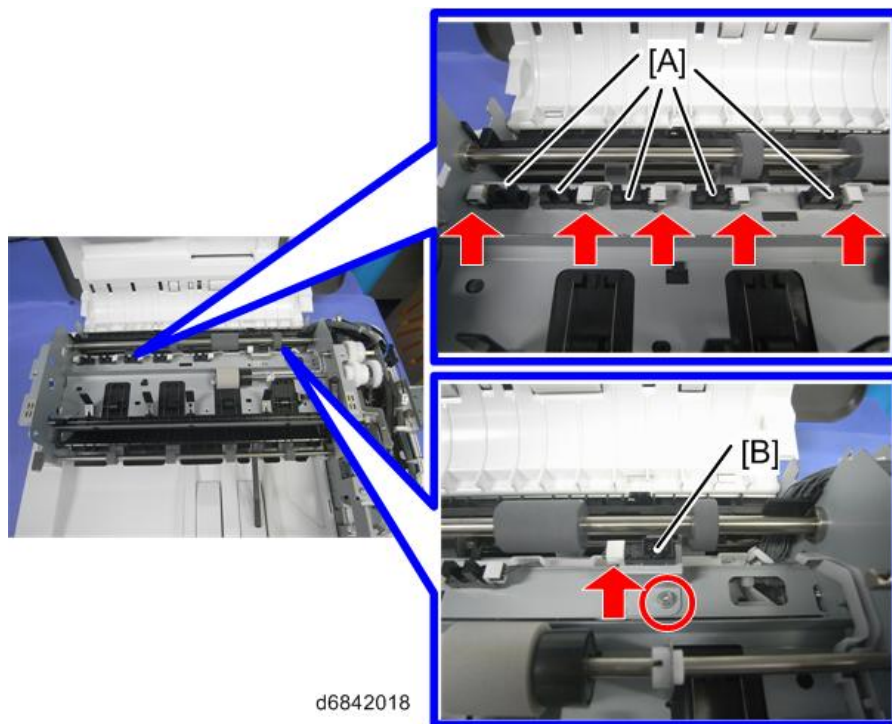

Original Exit Sensor

1. Original feed-in guide plate (Original Set Sensor)

Note

- The original exit sensor [A] is located in the ARDF mainframe.

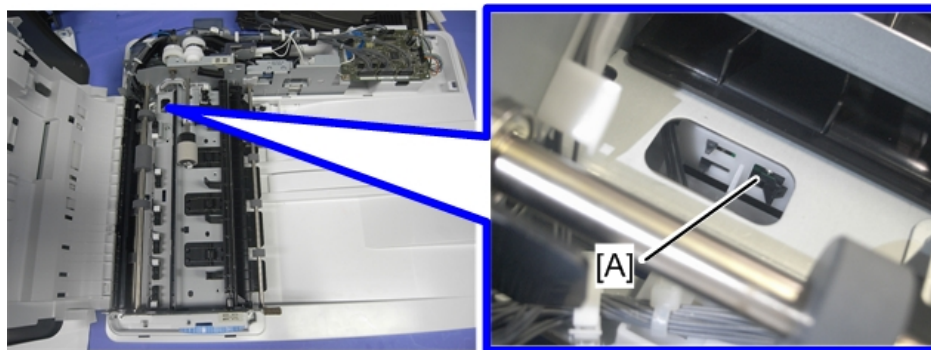

2. Original exit sensor bracket [A] ( ×1)

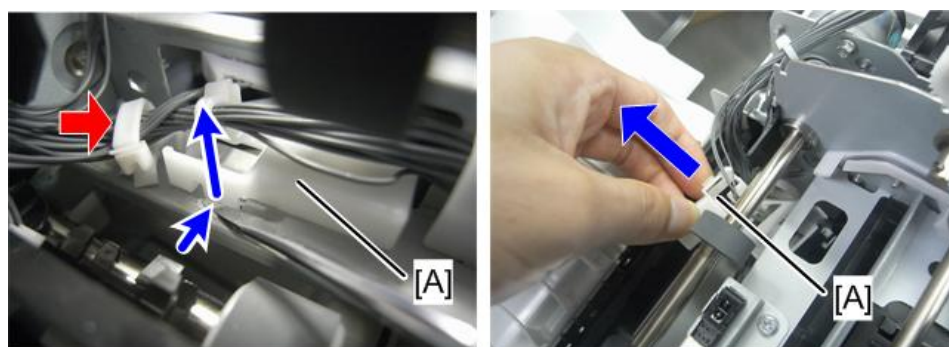

1.Replacement and Adjustment

- 3.** Original exit sensor [A] (📦 ×1)

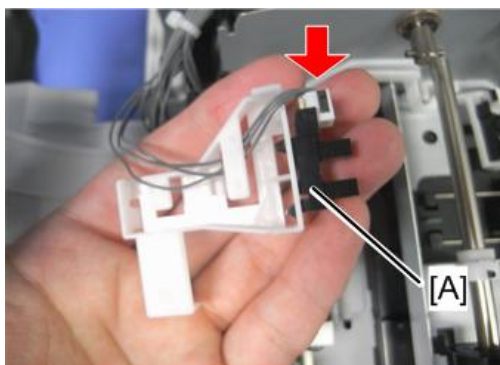

d6842028

Registration Sensor

- 1.** Original feed-in guide plate (Original Set Sensor)
2. Registration sensor [A] (📦 ×1)

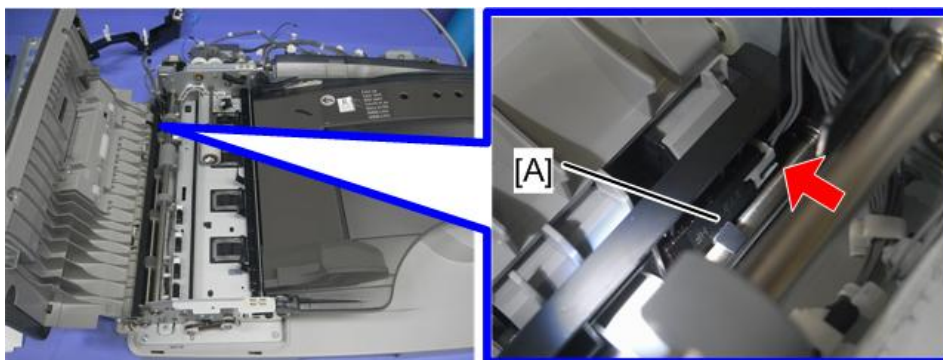

d7242002

DF Position Sensor

- 1.** ARDF Drive Board (ARDF Drive Board)
2. DF position sensor with bracket [A] (📦 ×1)

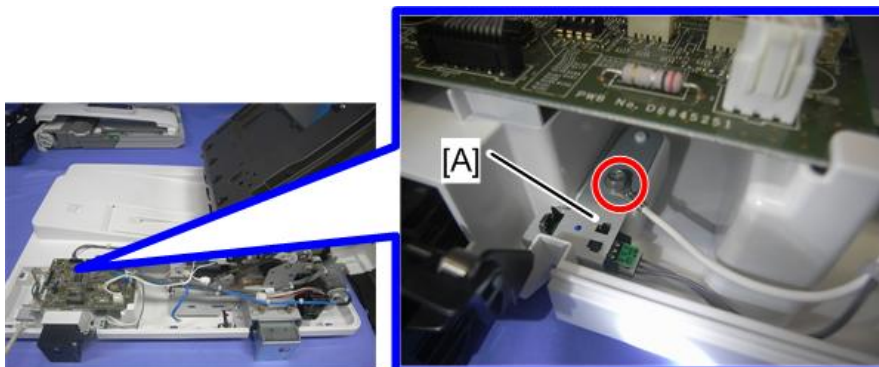

d6842008

- 3.** DF position sensor [A] (🔌 ×1)

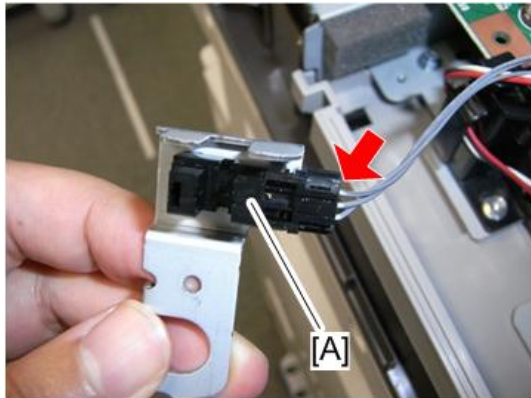

d578r507

Left Cover Switch

- 1.** Rear cover (Rear Cover)
2. Left cover switch [A] (🔩 ×2, 📌 ×2)

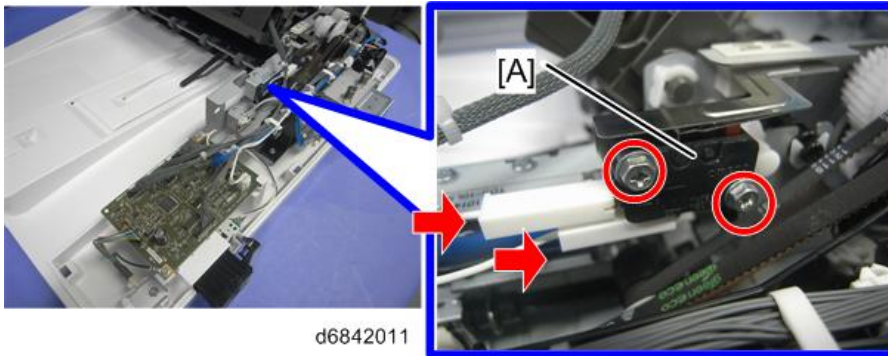

d6842011

Motors, Solenoids, and Clutches

Feed Motor

1. Rear cover (Rear Cover)
2. Feed motor harness [A] (📦×1)

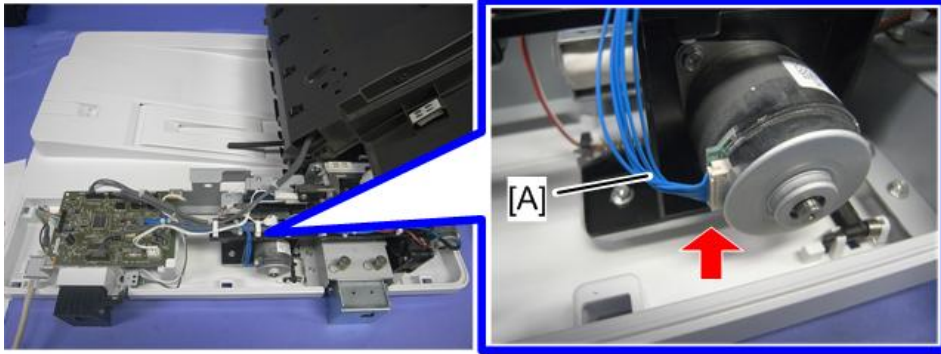

d6842003

3. Harness guide [A] (📦×5)

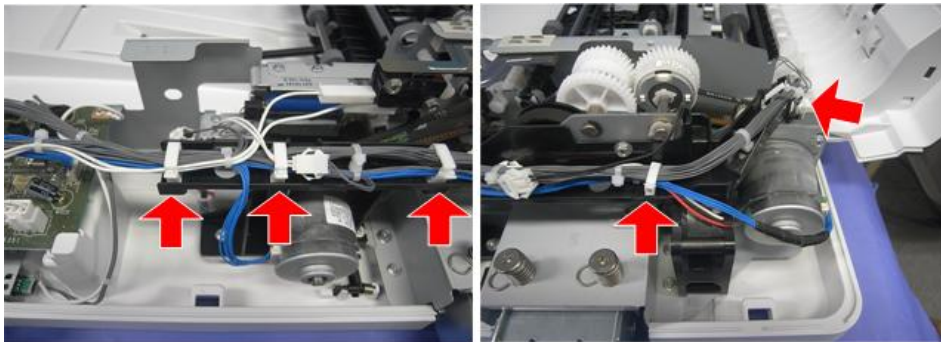

d6842002

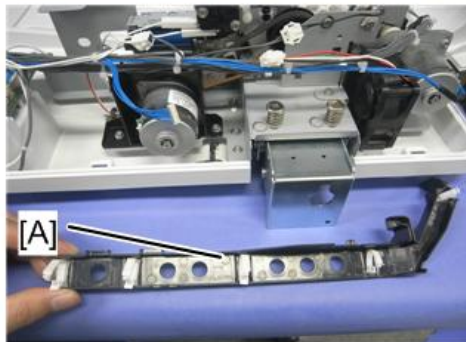

4. Feed motor with bracket [A] (⊕×2, spring [B]×1, ⊕ ×1)

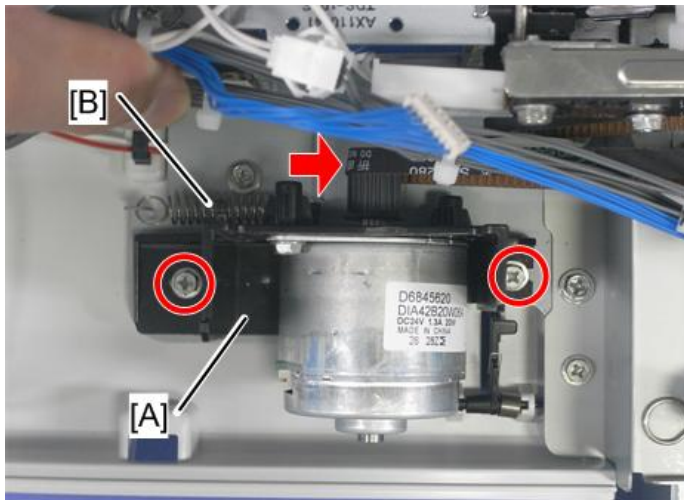

d6842004

5. Feed motor [A] (⊕×2)

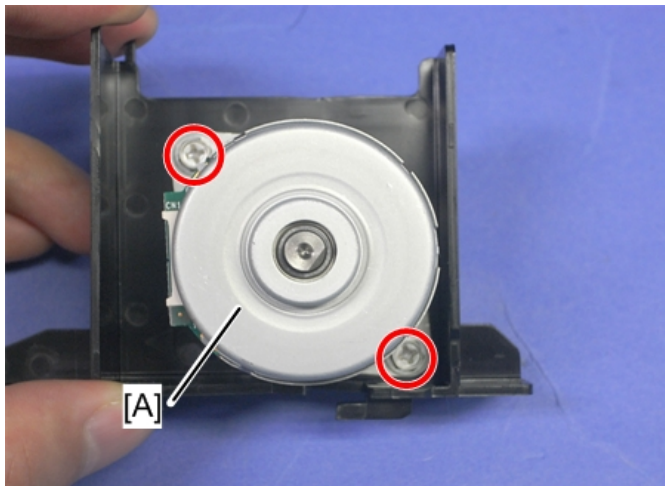

d6842005

Transport Motor

1. Rear cover (Rear Cover)
2. Transport motor bracket [A] (spring ×1, ⊕×2, ⊕ ×1)

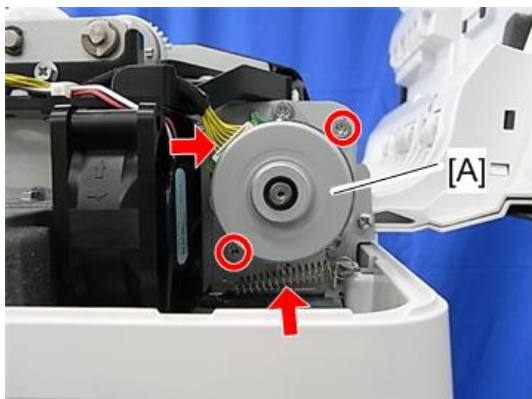

d146z0031

1.Replacement and Adjustment

3. Transport motor [A] (🔩×2)

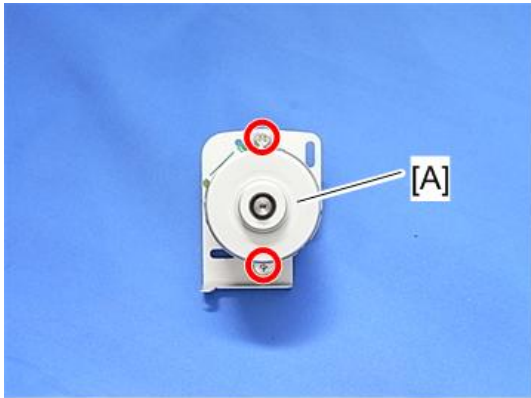

d146z0032

Stamp Solenoid

1. Rear cover (Rear Cover)

2. Stamp solenoid harness [A] (🔌×1, 🔩×1)

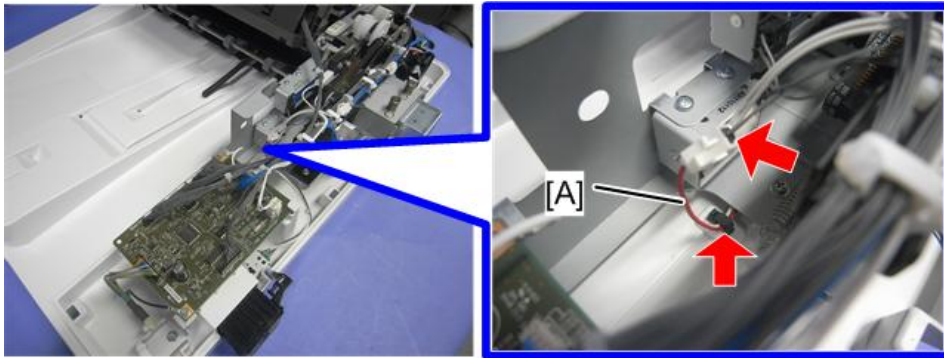

d6842023

3. Open the DF and remove the platen sheet [A].

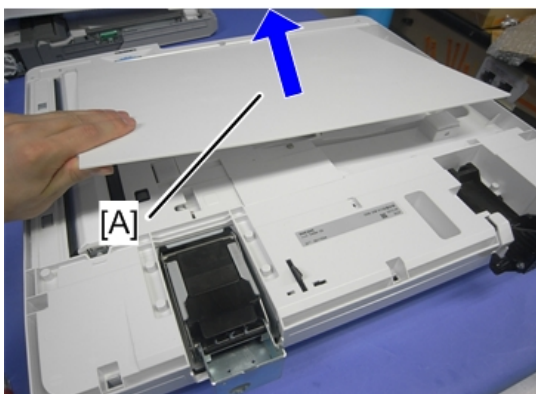

d6842020

- 4.** Stamp solenoid cover [A] (🔩×1)



- 5.** Stamp solenoid [A] (🔩×1)

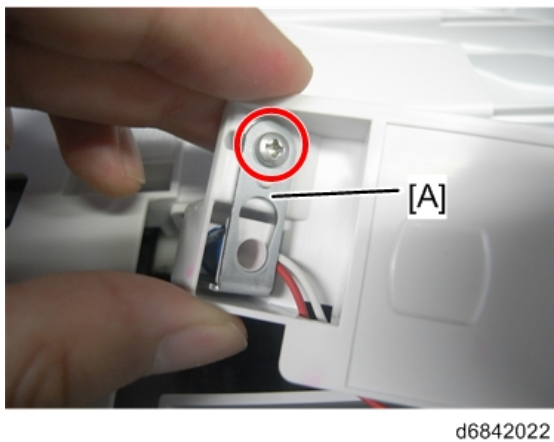

- 6.** Pull out the harness [A].

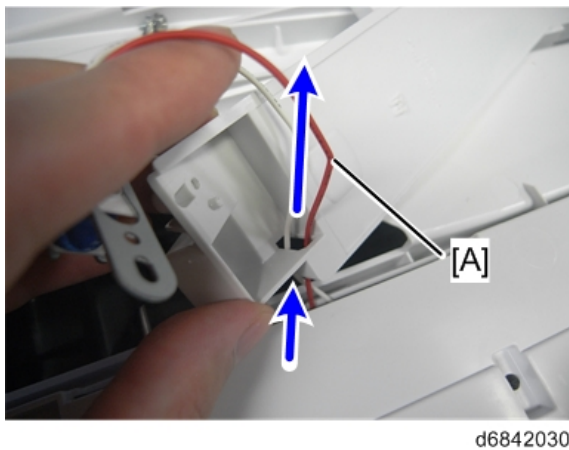

Pick-up Solenoid

- 1.** Rear cover (Rear Cover)
- 2.** Harness guide (Feed Motor)

1.Replacement and Adjustment

- 3.** Pick-up solenoid [B] (⚙️×2, 📦×1)

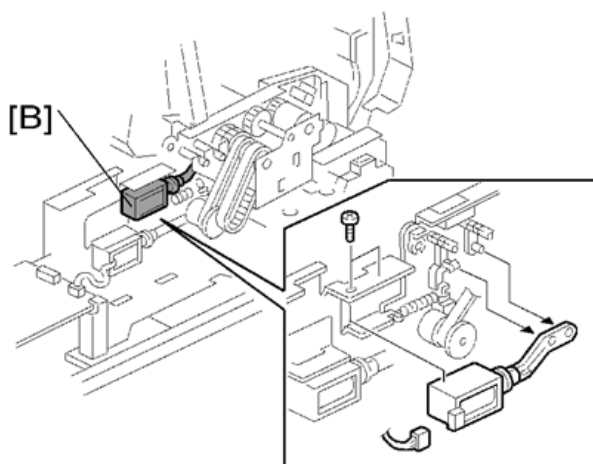

Inverter Solenoid

- 1.** Rear cover (Rear Cover)
2. Harness guide (Feed Motor)
3. Inverter solenoid [A] (⚙️×2, 📦×1, ⚙️×1, gear×1, gear cover×1, 📦×1)

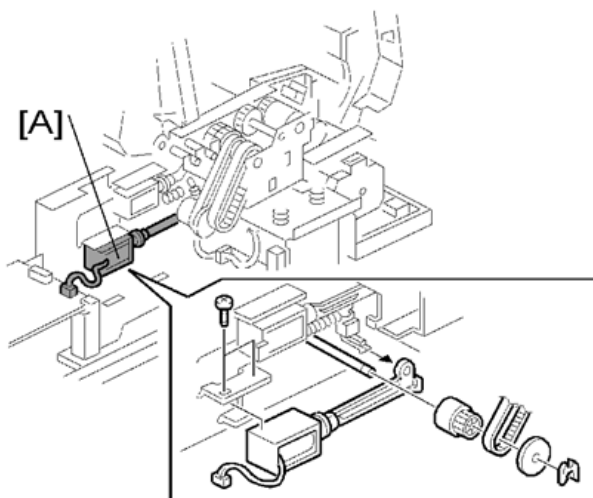

Feed Clutch

- 1.** Rear cover (Rear Cover)
2. Original feed unit (Original Feed Unit)

- 3.** Feed clutch [A] (⚙️×2, bushing ×1, shaft ×1, ⚙️×1, ⚙️×1)

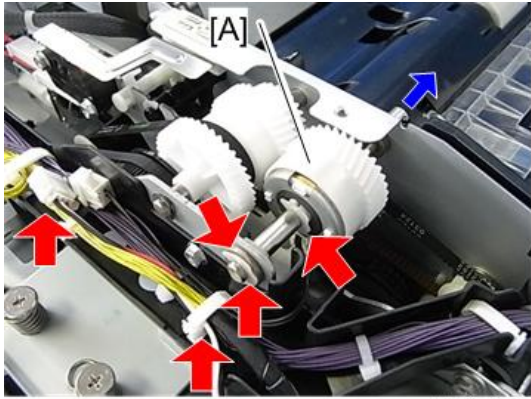

d146z0030

Belt and Rollers

Feed Belt

1. Original feed unit ([Original Feed Unit](#))
2. Feed belt cover [A] (spring×1)

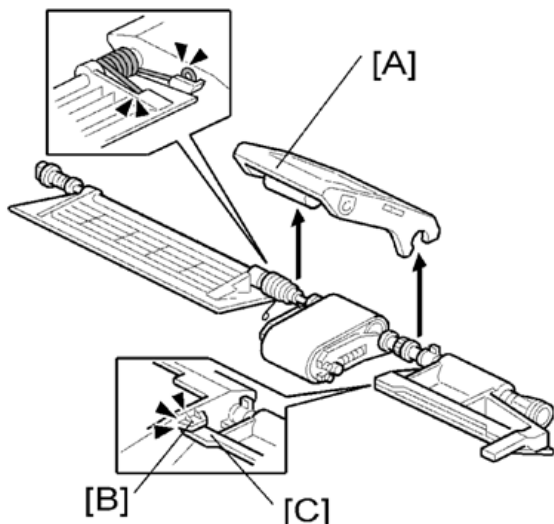

Note

- When reattaching the feed belt cover, make sure that the projection [B] of the feed belt cover is on the guide plate rear [C].

3. Belt tension unit [D]

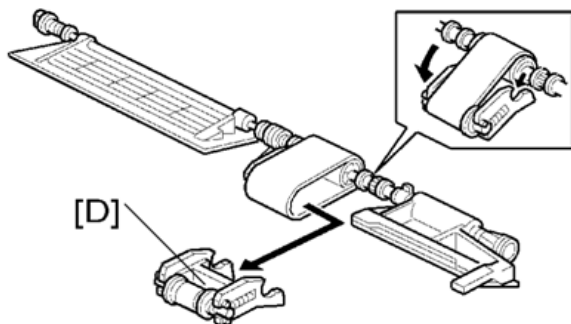

4. Feed belt [E]

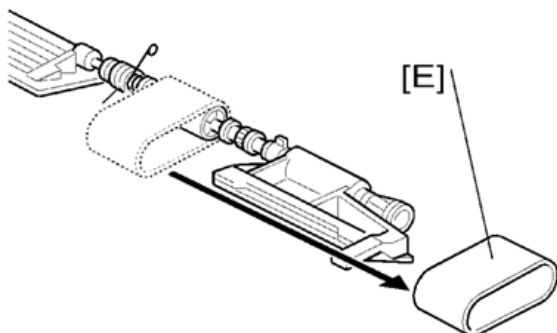

Pick-Up Roller

1. Original feed unit (Original Feed Unit)
2. Pick-up roller [A] (⌀×1)

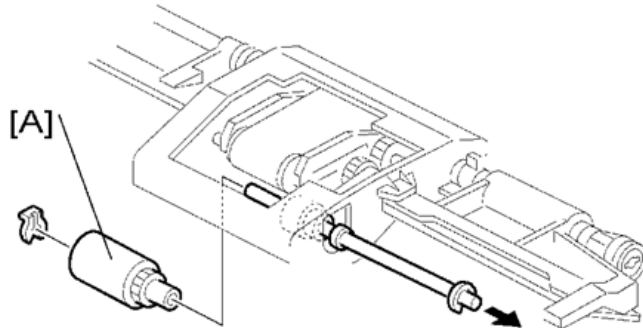

Separation Roller

1. Original Feed Unit (Original Feed Unit)
2. Separation roller cover [A]

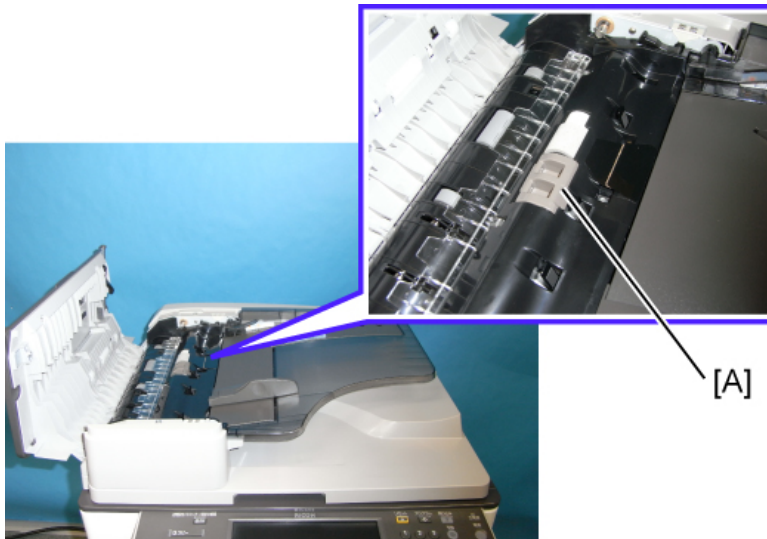

d578r503

3. Separation roller [A] (⌀×1)

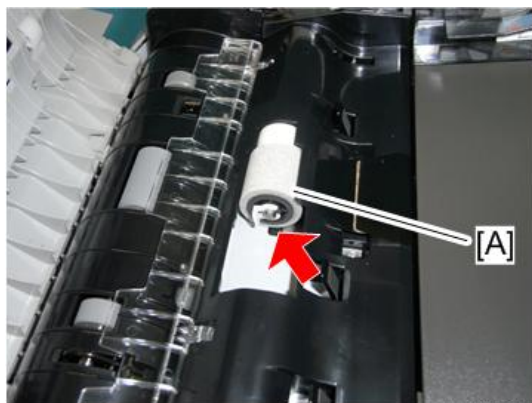

d578r504

Board

ARDF Drive Board

1. Rear cover ([Rear Cover](#))
2. ARDF drive board [A] (Ⓜ ×2, Ⓜ ×7)

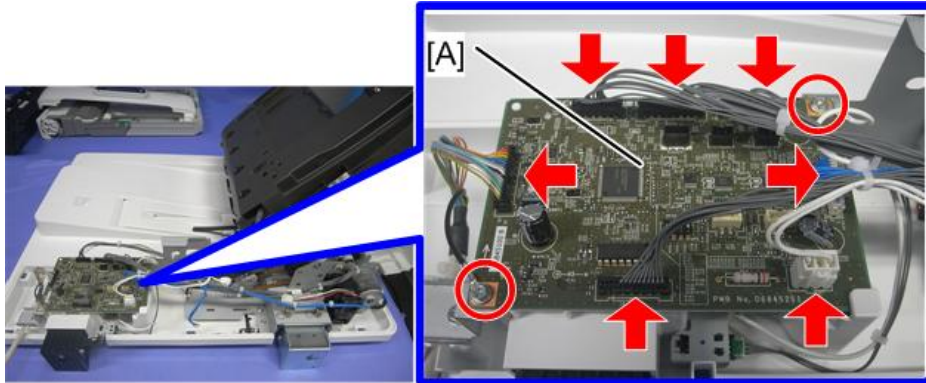

d6842007

2. Detailed Descriptions

ARDF DF3090 (D779)

Parts Layout

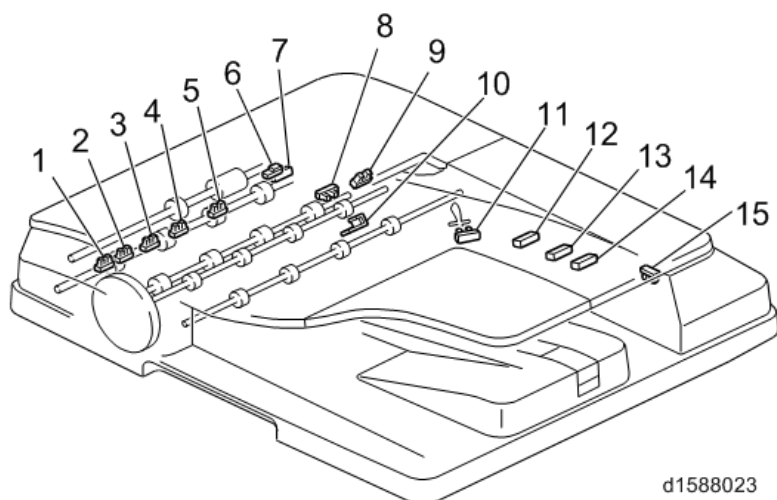

d1588023

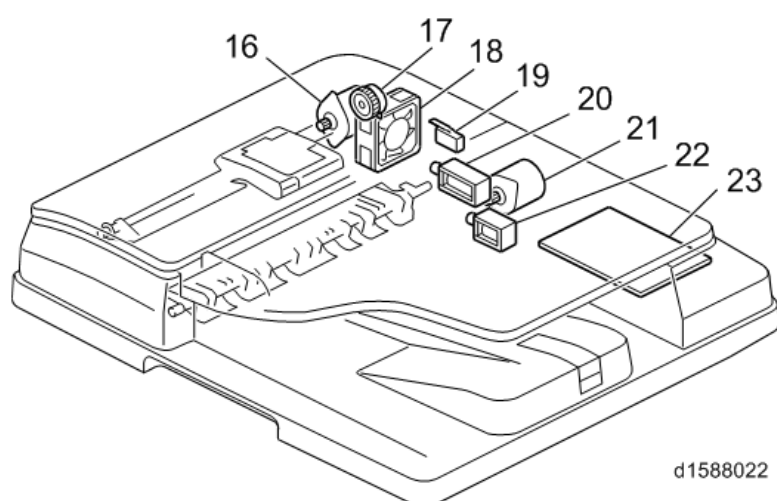

d1588022

| No. | Description | No. | Description |
|-----|------------------------------|-----|----------------------------|
| 1 | Original Width Sensor 5 (LL) | 13 | Original Length Sensor (M) |
| 2 | Original Width Sensor 4 (L) | 14 | Original Length Sensor (L) |
| 3 | Original Width Sensor 3 (M) | 15 | DF Position Sensor |
| 4 | Original Width Sensor 2 (S) | 16 | Transport Motor |
| 5 | Original Width Sensor 1 (SS) | 17 | Feed Clutch |
| 6 | Skew Correction Sensor | 18 | Cooling Fan Motor |
| 7 | Registration Sensor | 19 | Cover Switch |
| 8 | Original Exit Sensor | 20 | Pick-up Solenoid |

2.Detailed Descriptions

| No. | Description | No. | Description |
|-----|----------------------------|-----|-------------------|
| 9 | Original Set Sensor | 21 | Feed Motor |
| 10 | Stamp Solenoid | 22 | Inverter Solenoid |
| 11 | Original Sensor | 23 | ARDF Drive Board |
| 12 | Original Length Sensor (S) | - | - |

Mechanism

Original Detection

When an original is placed on the original tray correctly, the edge of the original pushes up the feeler of the original sensor.

Original Size Detection / Original Set Detection Mechanism

Five original width sensors detect the width of the original just when the leading edge of the original passes the interval sensor. Three original length sensors on the original table detect the length. These two pieces of size information summarize the original size.

| Size (Width x Length: mm) | | Width Detection | | | | | Length Detection | | |
|---------------------------|-----------------------|-----------------|----|----|----|----|------------------|----|-----|
| | | 1 | 2 | 3 | 4 | 5 | S | M | L |
| 1 | A3 SEF (297 x 420) | On | On | On | On | On | On | On | On |
| 2 | B4 SEF (257 x 364) | On | On | On | - | - | On | On | On |
| 3 | A4 SEF (210 x 297) | On | On | - | - | - | On | On | - |
| 4 | A4 LEF (297 x 210) | On | On | On | On | On | - | - | - |
| 5 | B5 SEF (182 x 257) | On | - | - | - | - | On | | - |
| 6 | B5 LEF (257 x 182) | On | On | On | - | - | | | - |
| 7 | A5 SEF (148 x 210) | On | - | - | - | - | | | - |
| 8 | A5 LEF (210 x 148) | On | On | - | - | - | | | - |
| 9 | B6 SEF (128 x 182) | - | - | - | - | - | | | - |
| 10 | B6 LEF (182 x 128) | On | - | - | - | - | - | - | - |
| 11 | 11" x 17" SEF (DLT) | On | On | On | On | - | On | On | On* |
| 12 | 11" x 15" SEF | On | On | On | On | - | On | On | On* |
| 13 | 8 1/2" x 11" SEF (LT) | On | On | - | - | - | On | - | - |
| 14 | 11" x 8 1/2" LEF (LT) | On | On | On | On | - | - | - | - |

* The machine cannot tell the difference between certain original sizes, such as DLT (11 x 17") and 11 x 15". The machine assumes such originals are 11 x 17". To change this, use SP mode.

Sensor Position

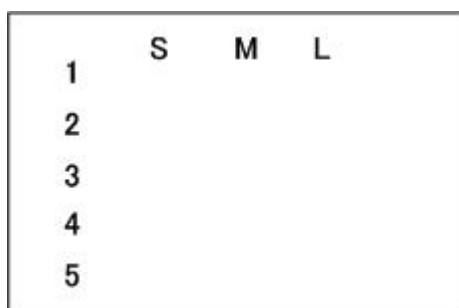

d779f0002

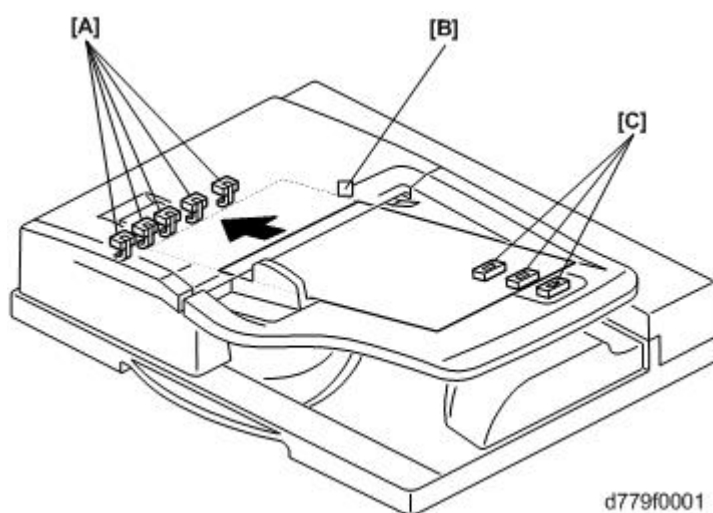

d779f0001

| | Description |
|---|-------------------------|
| A | Original Width Sensors |
| B | Original Set Sensor |
| C | Original Length Sensors |

Paper Feed / Separation Mechanism

The separation mechanism uses the RF method.

When the originals are placed and [Start] is pressed, the paper feed solenoid is turned ON and the pickup roller [A] goes down to the original. At this time, the paper feed motor [B] switches on and the pickup roller and paper feed motor [B] start rotating. Then a sheet of paper is fed.

2.Detailed Descriptions

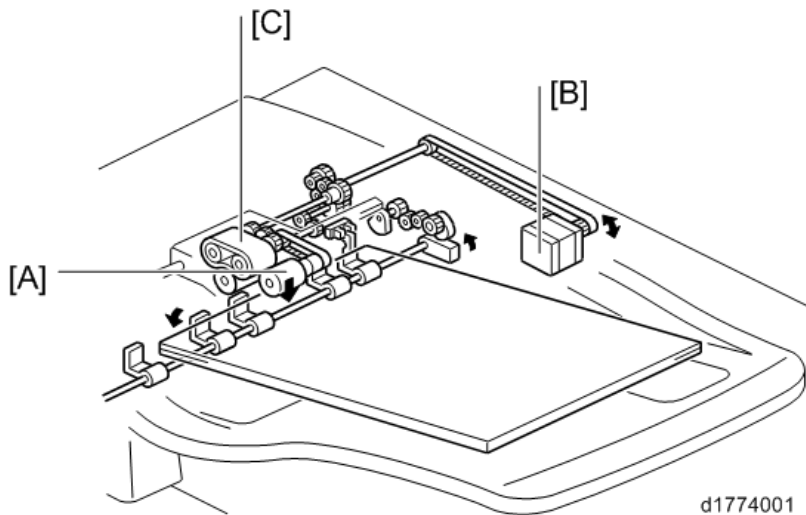

| | Description |
|---|------------------|
| A | Pickup Roller |
| B | Paper Feed Motor |
| C | Paper Feed Belt |

Skew Correction Mechanism, Registration Mechanism

- Skew Correction

This machine adjusts paper skew by hitting the originals against the pullout roller [A].

The skew correction sensor [B] detects the leading edge of the original after it passes through the separation area.

After hitting the originals against the pullout roller and making a buckle in the original, the transport motor turns ON. This mechanism prevents skewed feeding of the originals.

- Registration Mechanism

The registration sensor [C] detects the leading edge of the originals. The machine uses the data for registration during copying.

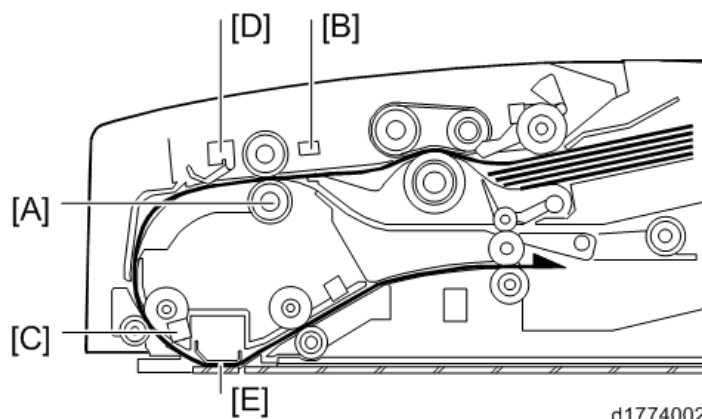

| | Description |
|---|------------------------|
| A | Pullout Roller |
| B | Skew Correction Sensor |
| C | Registration Sensor |

| | |
|---|------------------------------|
| | |
| D | Original Width Sensor |
| E | Sheet-through Exposure Glass |

- Transport Mechanism (Simplex)

Originals are transported by the pullout roller [A] and the entrance transport roller [B] to the sheet-through exposure glass [C], which scans the image. After this process, the originals are transported to paper exit section by the exit transport roller [D] and the exit driven roller [E].

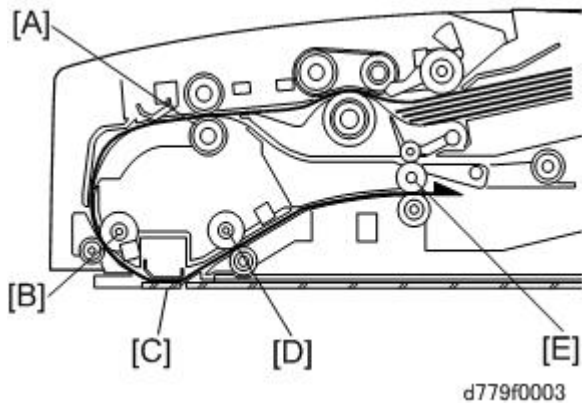

| | Description |
|---|------------------------------|
| A | Pullout Roller |
| B | Entrance Transport Roller |
| C | Sheet-through Exposure Glass |
| D | Exit Transport Roller |
| E | Exit Driven roller |

- Transport Mechanism (Duplex)

When originals are detected by the skew correction sensor [A], the transport motor switches OFF and the original stops for a while. After skew correction, the originals are re-transported to the sheet-through exposure glass [B], which scans the first side (front). Then the inverter solenoid switches ON and the junction gate [C] opens. By that process, the originals are transported to the reverse roller. At this time, the transport motor stops and the inverter solenoid switches off.

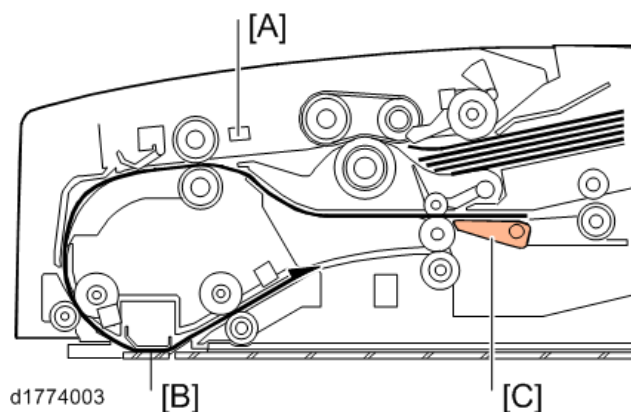

| | Description |
|---|------------------------|
| A | Skew Correction Sensor |

2.Detailed Descriptions

| | Description |
|---|------------------------------|
| B | Sheet-through Exposure Glass |
| C | Junction Gate |

The originals, which reached the reverse roller, are re-fed over the upper surface of the junction gate [A]. When the originals reach the sheet-through exposure glass [B], the second side (back) is scanned. To make the order of the sheets on the exit tray correct, the two sides (front/back) of the original need to be inverted. Therefore, the inverter solenoid switches ON and the originals are transported to the reverse roller again. After the inversion, the originals exit onto the exit tray [C].

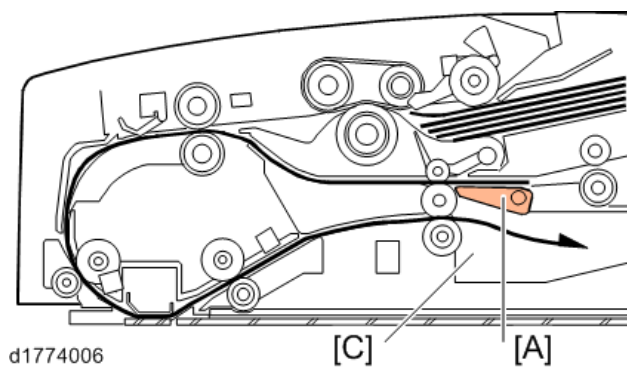
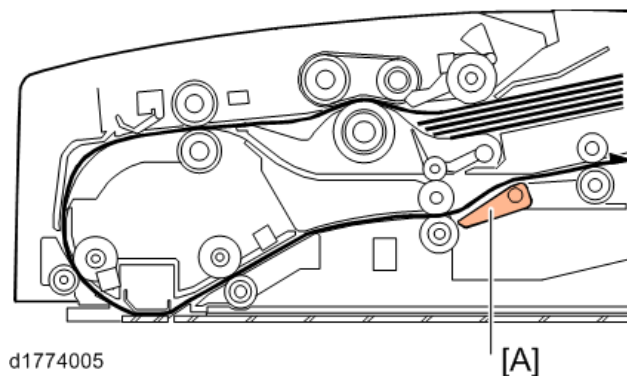
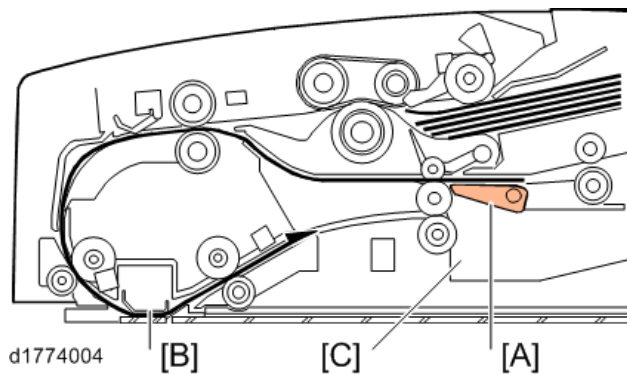

SP6-901-002 (Setting to give priority to stackability)

To improve the alignment of the delivered originals, select to give priority to stackability in the following SP. This will reduce the originals' delivery speed and improve their stackability.

- **SP6-901-002** (Setting to give priority to stackability): for DF3090
 - 0: Higher throughput (default)
 - 1: Higher stackability